

 **acumed**<sup>®</sup>  
Product Catalog

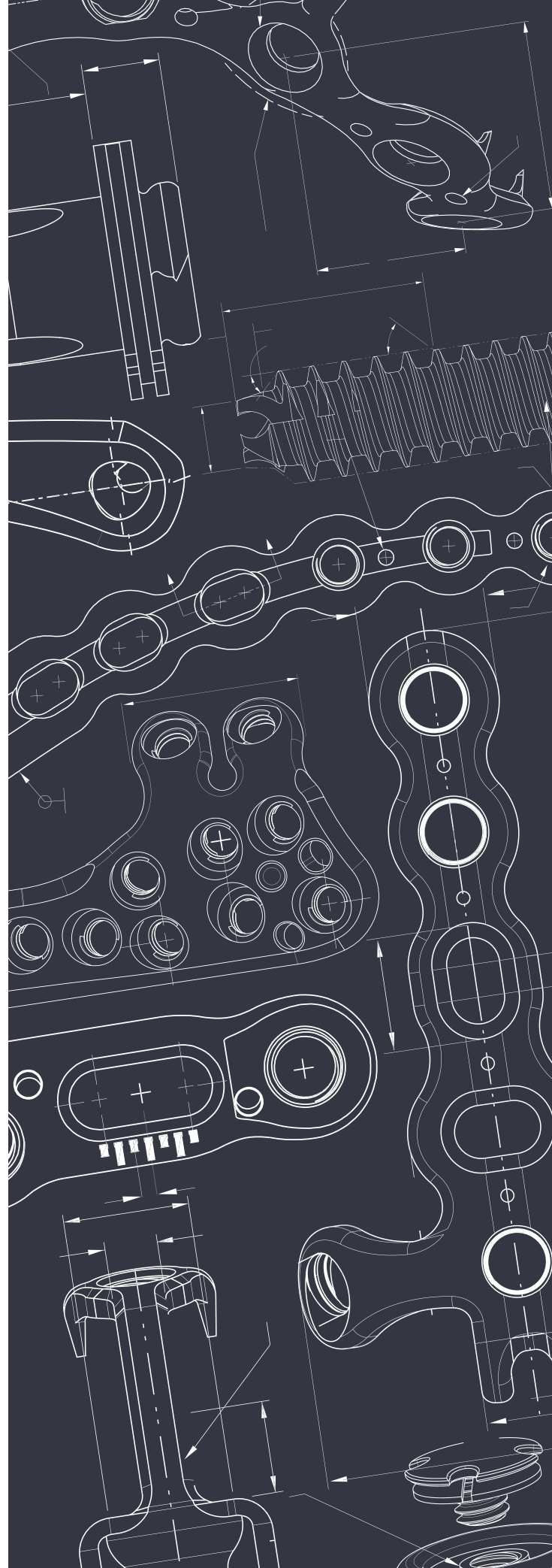

Acumed® is a global leader of innovative orthopaedic and medical solutions.

We are dedicated to developing products, service methods, and approaches that improve patient care.

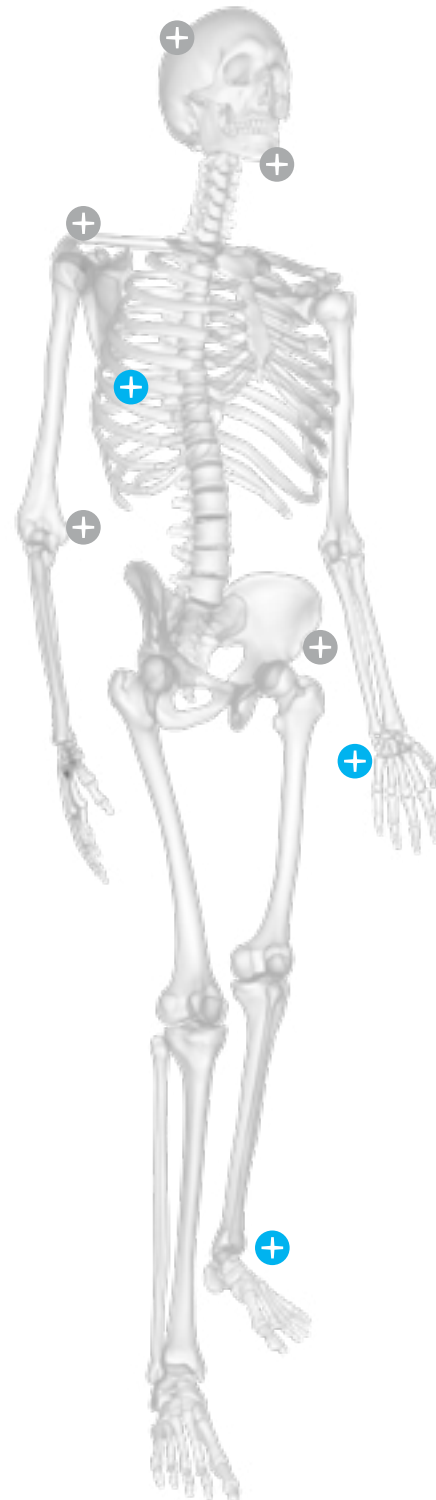

## Building on 35 Years of Innovation With Purpose

For more than three decades, Acumed has been dedicated to developing fracture solutions to treat indications from the upper to the lower extremity. Our innovative orthopaedic implants range from the original fully threaded headless compression screw to the first and only anatomically shaped radial head prosthesis.









In March 2022, Acumed expanded its portfolio and began managing the OsteoMed product line to better serve customers worldwide. Our repertoire now includes OsteoMed's comprehensive lower extremity, craniomaxillofacial (CMF), neurological, and orthobiologics solutions.

Acumed's global market position was further solidified with the acquisition of ExsoMed in July 2022, enhancing our portfolio of upper extremity solutions for simple to complex injuries.

Headquartered in Hillsboro, Oregon, Acumed has a global distribution network with offices worldwide. We are committed to partnering with surgeons and hospitals to provide orthopaedic solutions designed to improve patient outcomes.

# Table of Contents

## Section

	Screw, Pin, & Staples .....	<b>1</b>
	Shoulder .....	<b>33</b>
	Chest Wall .....	<b>51</b>
	Elbow .....	<b>59</b>
	Hand & Wrist .....	<b>73</b>
	Hip & Pelvis .....	<b>115</b>
	Foot & Ankle .....	<b>119</b>
	Orthobiologics .....	<b>161</b>
	Tendon & Ligament .....	<b>175</b>





## Screw, Pin, & Staples Product Lineup

Acutrak 2® Headless Compression Screw System .....	<b>2</b>
Acutrak® Headless Compression Screw System.....	<b>4</b>
AcuTwist® Acutrak® Compression Screw .....	<b>6</b>
Biotrak® Headless Resorbable Compression System.....	<b>8</b>
ExtremiFix™ Cannulated Screw System Mini   Small .....	<b>10</b>
Extremity Screw System .....	<b>12</b>
4.0 Cannulated Screw System .....	<b>14</b>
ExtremiFix™ Cannulated Screw System Midsize   Large Cannulated .....	<b>16</b>
6.5 & 7.3 mm Cannulated Screw System .....	<b>18</b>
InstaFix™ Shape Memory Fixation System .....	<b>20</b>
Tension Band Pin System .....	<b>22</b>
Inion FreedomPin® .....	<b>24</b>
Inion OTPS™ Pins .....	<b>26</b>
OR Essentials Kit .....	<b>28</b>
Large Cannulated Screws .....	<b>30</b>

⊕ Screw, Pin, & Staples

# Acutrak 2® Headless Compression Screw System

Introduced in 1994, the Acumed Acutrak® Headless Compression Screw revolutionized the way surgeons gain compression. The variable pitch of the screw thread allows the threads to cross the fracture site while generating compression along the entire shaft, unlike standard fully threaded bone screws.<sup>1</sup> Acutrak 2 is the latest generation of this groundbreaking technology.

Acutrak 2 Screws	Diameter	Length
Micro	Tip: 2.5 mm	1 mm increments 8–14 mm
	Tail: 2.8 mm	2 mm increments 14–30 mm
Mini	Tip: 3.5 mm	2 mm increments 16–30 mm
	Tail: 3.6 mm	
Standard	Tip: 4.0 mm	2 mm increments 16–34 mm
	Tail: 4.1 mm	
4.7 mm	Tip: 4.5 mm	2 mm increments 20–30 mm
	Tail: 4.7 mm	5 mm increments 30–50 mm
5.5 mm	Tip: 5.2 mm	5 mm increments 25–60 mm
	Tail: 5.5 mm	
7.5 mm	Tip: 7.0 mm	5 mm increments 40–120 mm
	Tail: 7.5 mm	



**Innovative Design**

The original fully threaded headless compression screw with continuously variable thread pitch

Cutting flutes are engineered for self-cutting and self-tapping

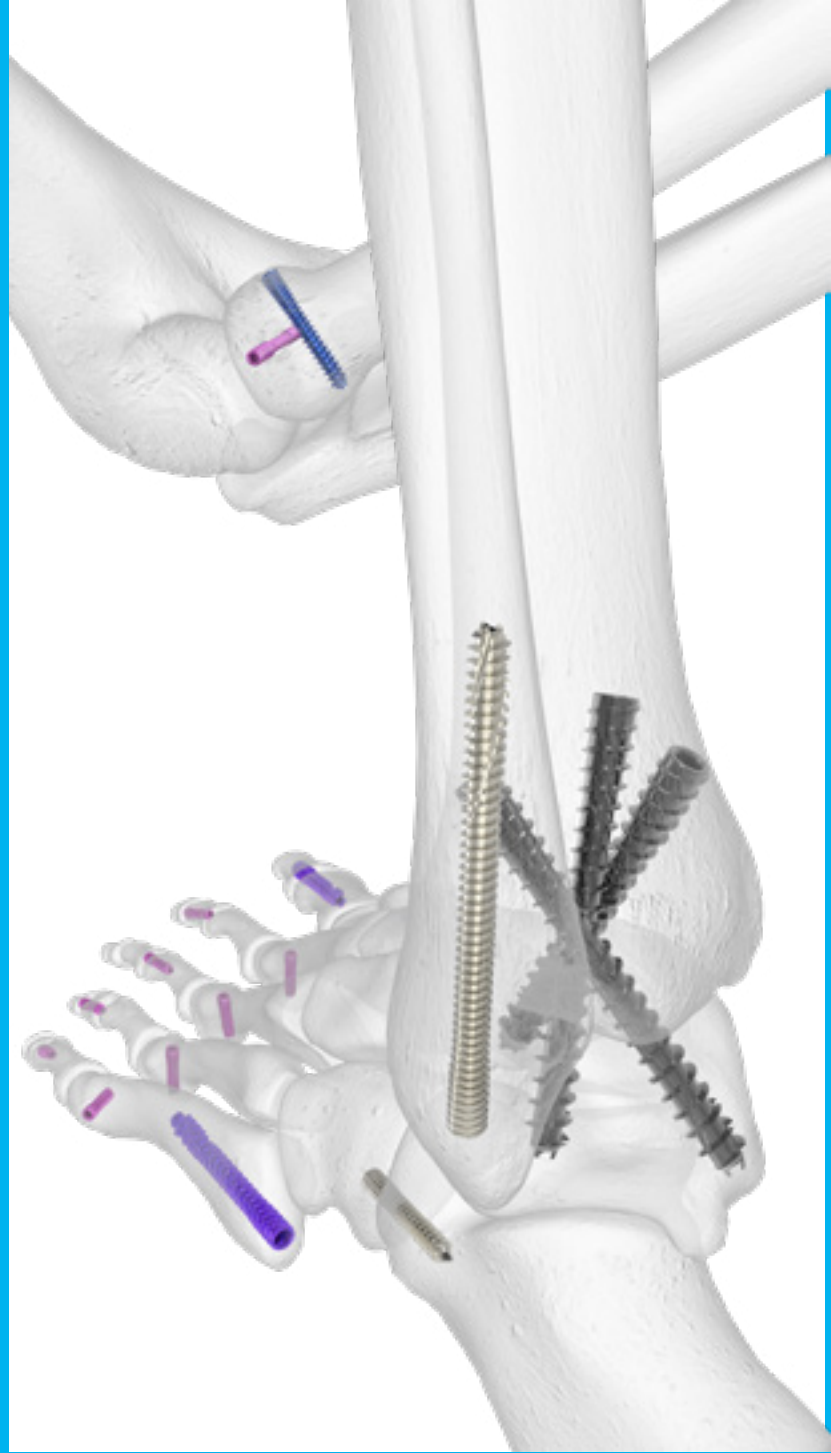

The Acutrak 2 Family of Screws



Micro Mini Standard 4.7 mm 5.5 mm 7.5 mm

1. Wheeler DL, McLoughlin SW. Biomechanical assessment of compression screws. *Clin Orthop Relat Res.* 1998;350:237-245.



# Trusted Over Two Million Times

by surgeons worldwide as their implant of choice

## Designed for Application in the Upper and Lower Extremities

Acutrak 2® screws are available in six different families for a total of 68 different screws, addressing applications in the upper and lower extremities as shown below

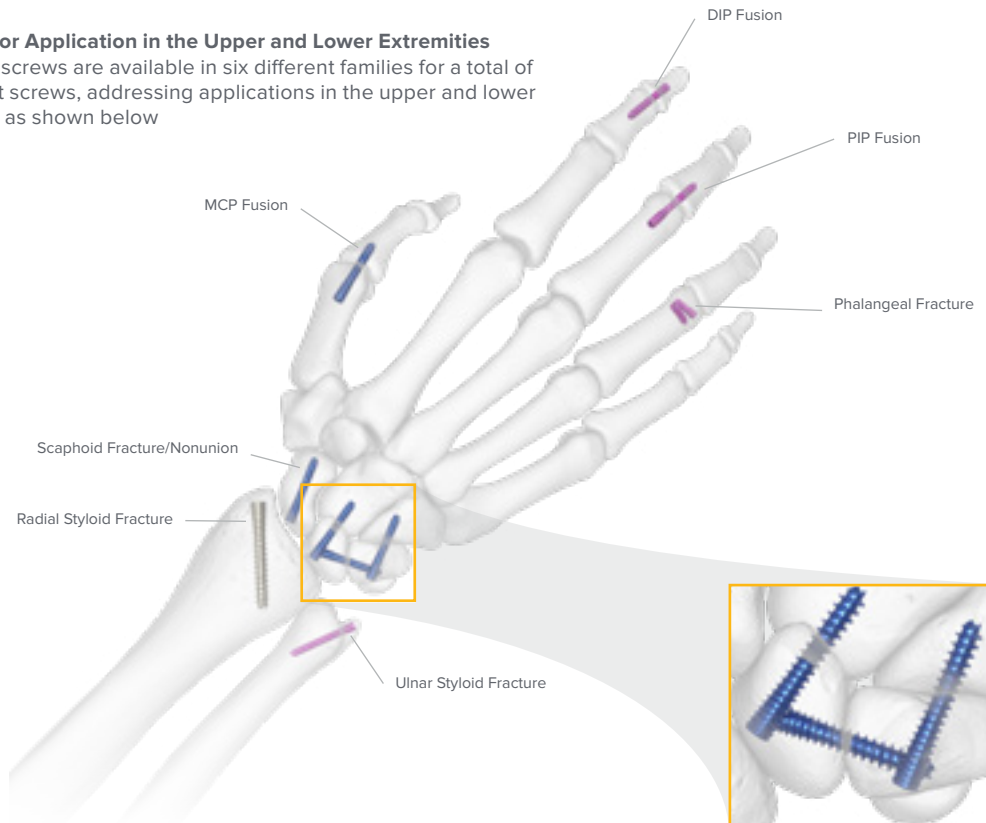

Four-corner Fusion

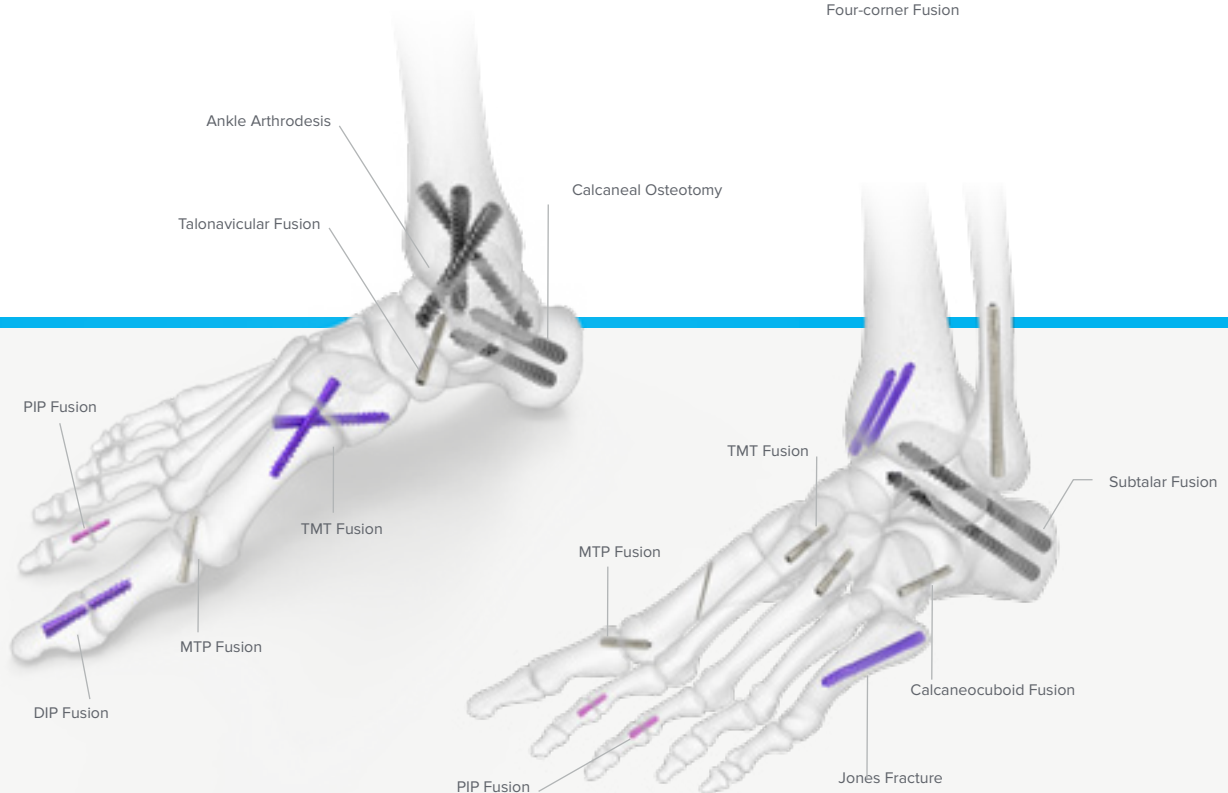

**Fully Threaded Length**

The fully threaded variable pitch and tapered profile are intended to work together to compress bone fragments into one rigid structure to help promote union

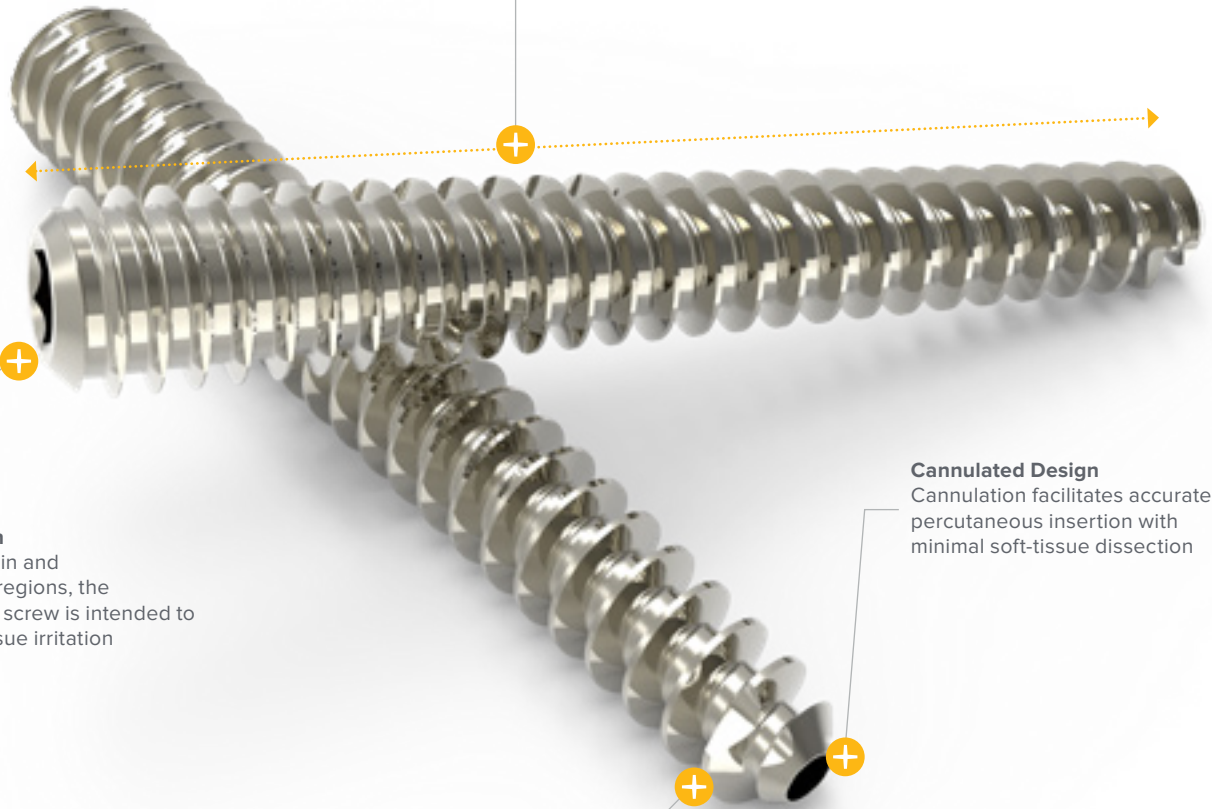

**Headless Design**

When implanted in and around articular regions, the headless-design screw is intended to minimize soft-tissue irritation

**Cannulated Design**

Cannulation facilitates accurate percutaneous insertion with minimal soft-tissue dissection

**Self-tapping**

Cutting flutes on both ends of the screw are intended to aid with insertion



**Trusted Over Two Million Times**  
by surgeons worldwide as their implant of choice

**The Acutrak Family of Screws**



Mini

Standard

4/5

Plus

6/7



The original fully threaded headless compression screw with continuously variable thread pitch



## Acutrak® Headless Compression Screw System

The Acumed Acutrak Headless Compression Screw System is designed to provide fixation in fractures, fusions, and osteotomies for a variety of upper and lower extremity applications. As a cannulated screw, Acutrak is designed to facilitate accurate percutaneous insertion while minimizing soft-tissue dissection.

Acutrak Screws	Diameter	Length
Mini	Tip: 2.8 mm Tail: 3.1–3.6 mm	8–26 mm 2 mm increments
Standard	Tip: 3.3 mm Tail: 3.8–4.6 mm	12.5–30 mm 2.5 mm increments
4/5	Tip: 4.0 mm Tail: 5.0 mm	25–50 mm 5 mm increments
Plus	Tip: 5.2 mm Tail: 6.5 mm	35–80 mm 5 mm increments
6/7	Tip: 6.0 mm Tail: 7.5 mm	40–120 mm 5 mm increments
Fusion	Tip: 2.0–3.3 mm Tail: 2.5–4.0 mm	14–24 mm 2 mm increments 27, 30, 32, & 37 mm
Hammertoe Fusion	Tip: 1.0 mm Tail: 2.5 mm	30 mm; 6 mm nose

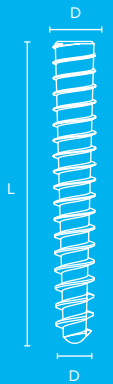

Fusion

Hammertoe Fusion



**Hammertoe Fusion**  
Fixation using the Acumed Hammertoe Fusion System





Trusted Over Two Million Times  
by surgeons worldwide as their implant of choice

**Break-away Groove**

Designed to snap off by gently bending back and forth until the screw fatigues at the break-off groove

**Headless Design**  
The screw's headless design is intended to minimize the risk of impingement or soft-tissue irritation

**Compression/Fully Threaded Length**

The fully threaded variable pitch and tapered profile are intended to work together to compress bone fragments into one rigid structure to help promote union

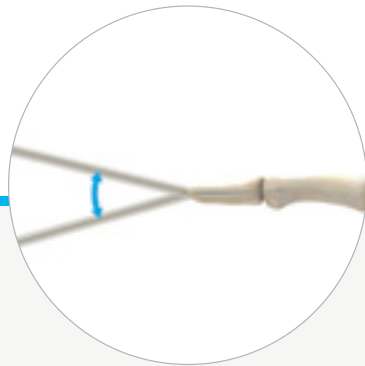

**Bend to Break off Excess**

When the screw is inserted, a gentle back-and-forth bend breaks off the excess at the groove

AcuTwist Compression Screw

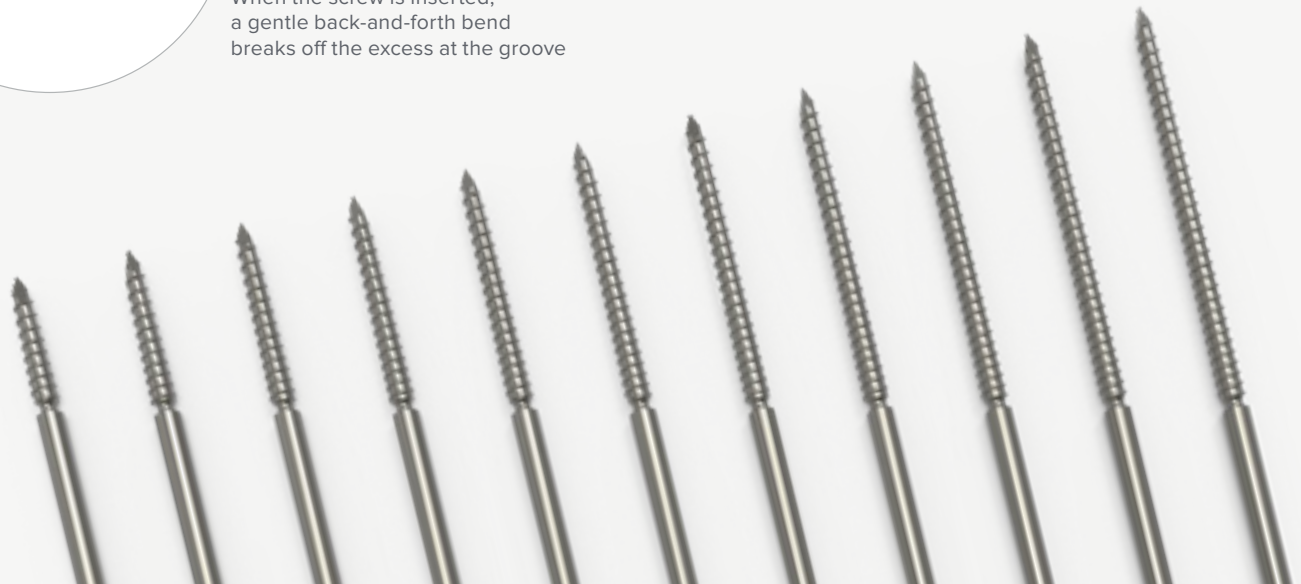

## AcuTwist® Acutrak® Compression Screw

Acumed's AcuTwist Acutrak Compression Screw is designed to provide compressive fixation for use in fractures, fusions, and osteotomies. Available in a range of lengths (10–30 mm), the screw includes a variable thread pitch, a tapered profile, a break-off groove, and threads along its entire length.

AcuTwist Acutrak Screws	Diameter	Length
Compression Screw	Tip: 1.5 mm Tail: 2.0 mm	10–30 mm 2 mm increments

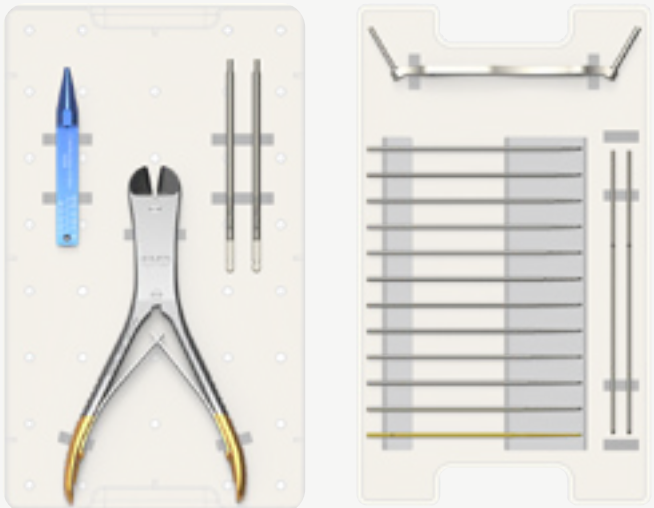
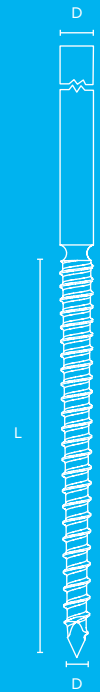

### Optional Accessories

These include the 2.0 mm Hex Wrench, Ratchet T-Handle A/O Connection and Tri-Lobe Quick Release, and AcuTwist Screw Handle



## Biotrak® Headless Resorbable Compression System

The Acumed Biotrak Headless Resorbable Compression System is designed for use in a wide variety of indications in the upper and lower extremities, including many fractures, fusions, and osteotomies. Biotrak solutions are made from 100% poly L-lactic acid (PLLA) that allows the implant to resorb as the bone heals.

Biotrak Screws	Diameter	Length
Mini	Tip: 3.2 mm Tail: 3.5–3.7 mm	16–24 mm 2 mm increments
Standard	Tip: 3.6 mm Tail: 4.3–4.7 mm	16–24 mm 2 mm increments
Pin	Tip: 2.0 mm Tail: 3.0 mm	20 mm, 30 mm, 40 mm
Helical Nail	Tip: 2.5 mm Tail: 3.2 mm	20 mm, 30 mm, 40 mm

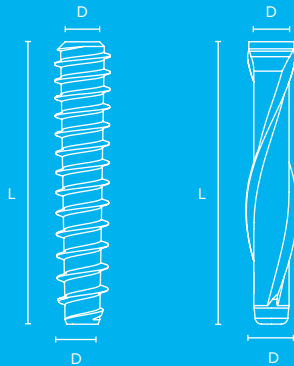

**OCD Lesion Fixation**  
MRI medial view of an OCD lesion fixated with a Biotrak Standard screw

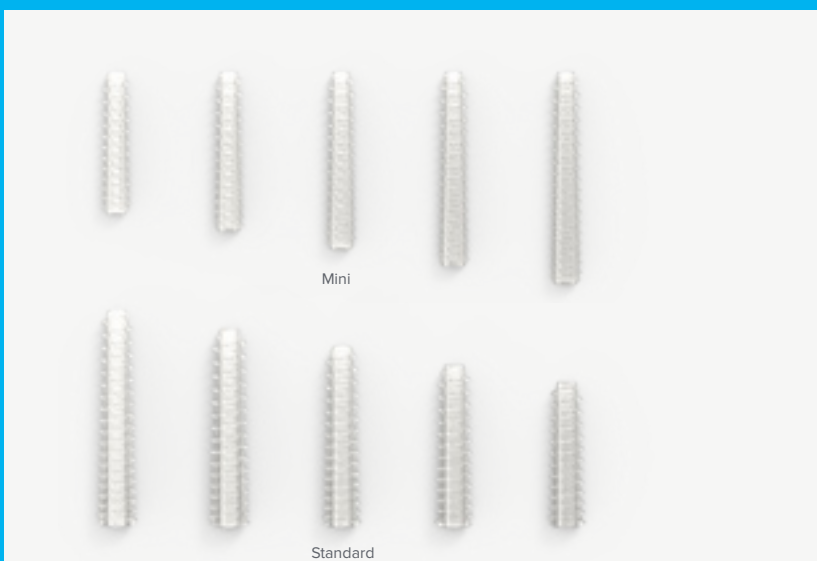





**Trusted Over Two Million Times**  
by surgeons worldwide as their implant of choice

**Headless Design**

Allows screws to be completely buried below the bone/cartilage surface to help prevent damage caused by a proud screw head



**Minimized Image Interference**  
Composed of PLLA, Biotrak® devices help minimize interference with imaging devices

**Completely Resorbable**  
Biotrak fixation devices are made from 100% poly L-lactic acid (PLLA), allowing the implant to resorb as the bone heals

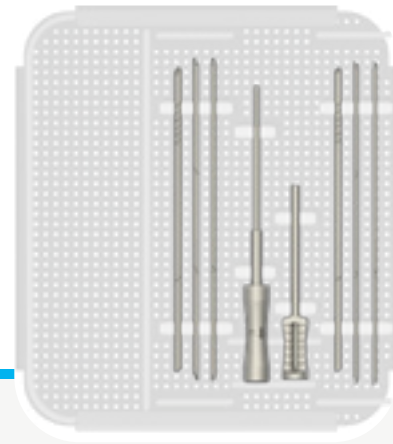

Pin

Helical Nail

## ExtremiFix™ Cannulated Screw System Mini | Small

The OsteoMed ExtremiFix Cannulated Screw System Mini | Small is designed to provide a minimally invasive method of anatomical fixation in upper and lower extremities. It is used in bone reconstruction, osteotomy, arthrodesis, and fracture fixation. Screws in the system are offered headed and headless in four diameters: 2.0, 2.4, 3.0, and 4.0 mm.

Headless Screws	Diameter	Length
2.0 mm Headless Cannulated Screws	Tip: 2.1 mm Tail: 2.7 mm	10–42 mm (2 mm increments)
2.4 mm Headless Cannulated Screws	Tip: 2.5 mm Tail: 2.9 mm	10–50 mm (2 mm increments)
3.0 mm Headless Cannulated Screws	Tip: 3.0 mm Tail: 3.9 mm	10–40 mm (2 mm increments)
4.0 mm Headless Cannulated Screws	Tip: 4.0 mm Tail: 4.4 mm	12–40 mm (2 mm increments) 44, 48, 52 mm

Headed Screws	Diameter	Length
2.0 mm Headed Cannulated Screws	Tip: 2.1 mm Tail: 2.7 mm	6–42 mm (2 mm increments)
2.4 mm Headed Cannulated Screws	Tip: 2.5 mm Tail: 2.9 mm	6–50 mm (2 mm increments)
3.0 mm Headed Cannulated Screws	Tip: 3.0 mm Tail: 3.9 mm	10–40 mm (2 mm increments)
4.0 mm Headed Cannulated Screws	Tip: 4.0 mm Tail: 4.4 mm	12–40 mm (2 mm increments) 44, 48, 52 mm

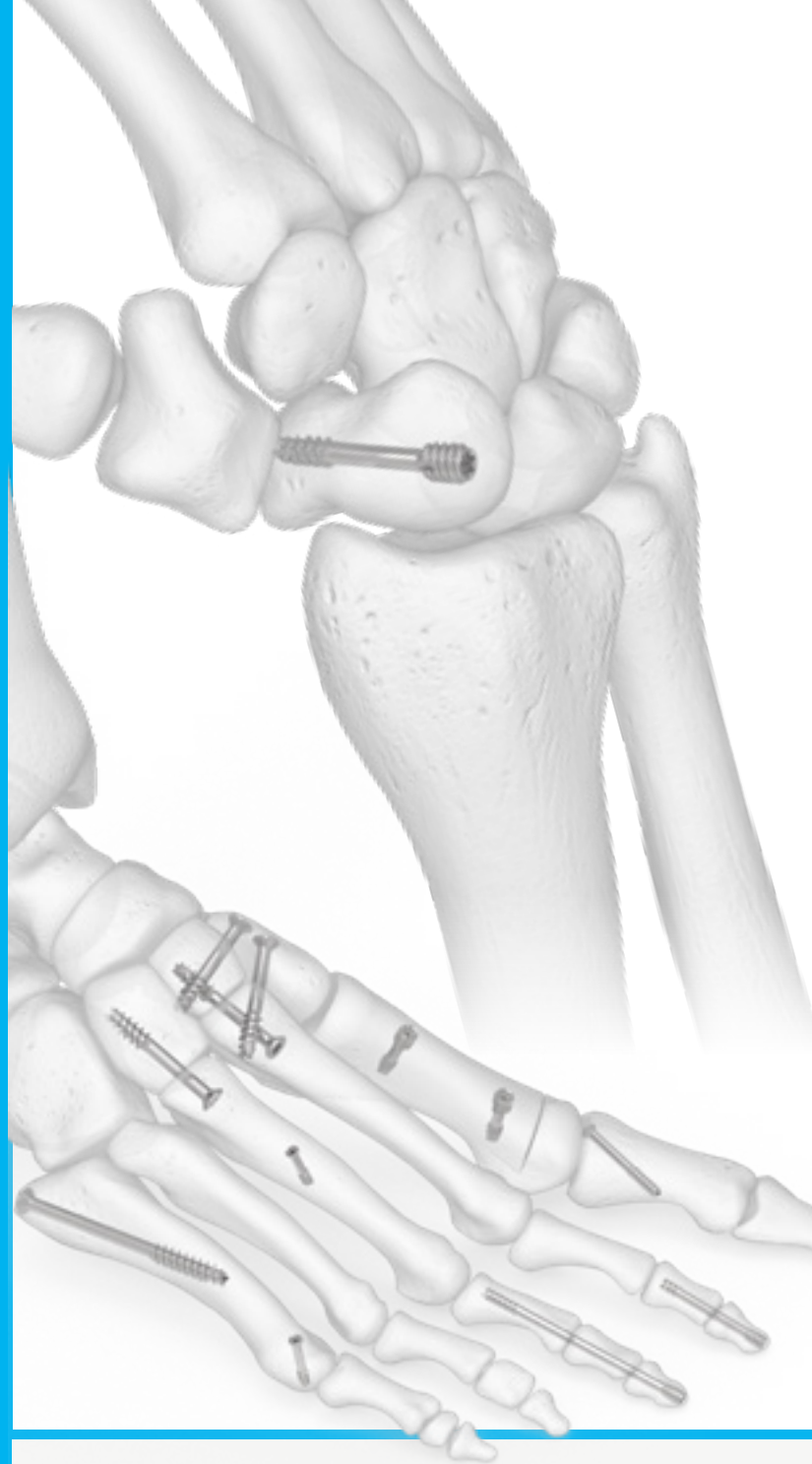

**Medial Malleolar Clamp**  
Designed to aid in placement of .045" guide wires while reducing and stabilizing the medial malleolar fragment

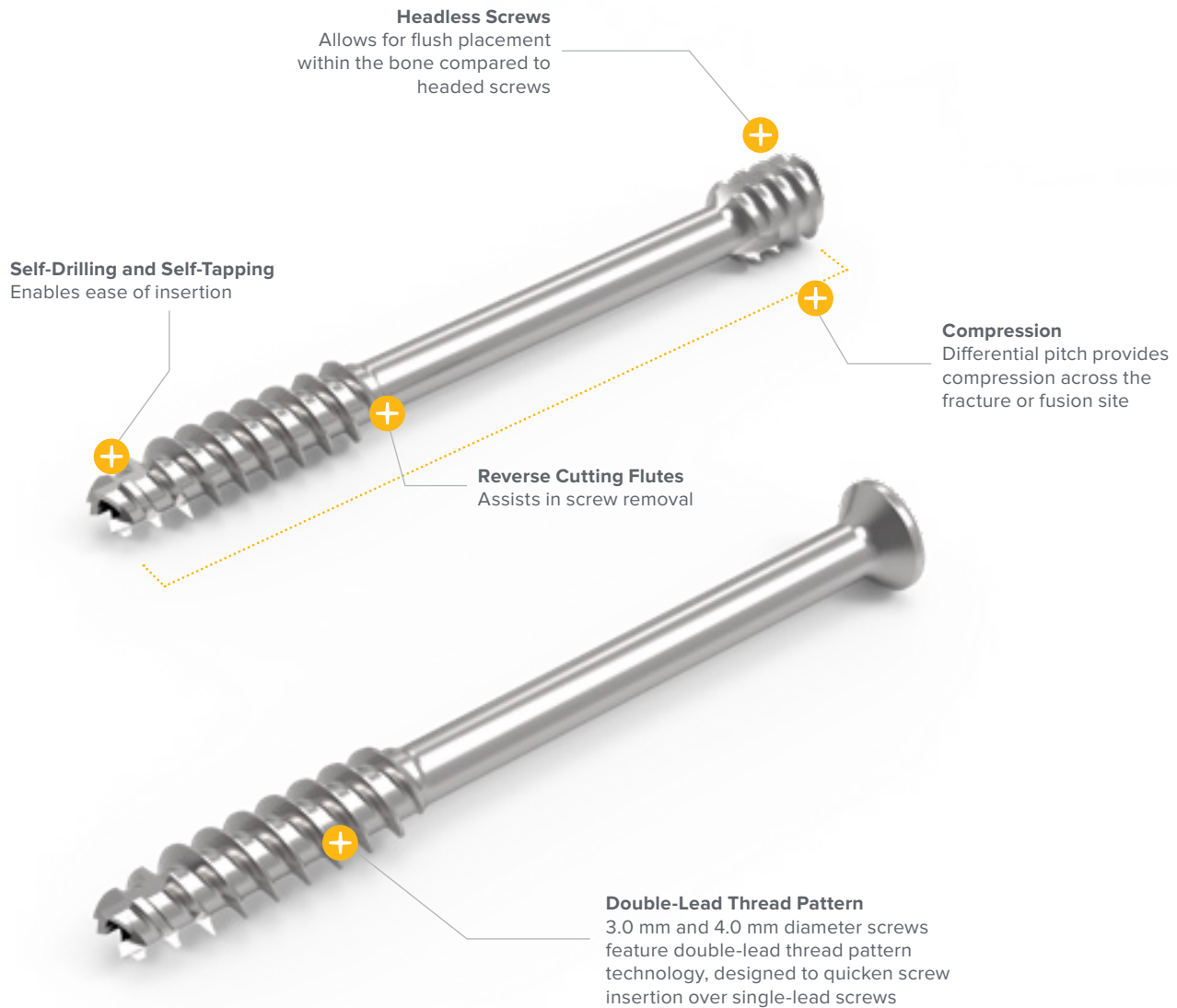

2.0 mm Cannulated Screws



2.4 mm Cannulated Screws



3.0 mm Cannulated Screws



4.0 mm Cannulated Screws

## Extremity Screw System

Acumed Extremity Screws are cancellous screws that are indicated for fracture and osteotomy fixation of the upper and lower extremities. Extremity screws are self-drilling and self-tapping. Screw placement is achieved with the use of heavy guide wires for solid bone stabilization.

Extremity Screws	Length	Threaded Length
2.7 mm Extremity Screws	12–24 mm 2 mm increments	7 mm
3.5 mm Extremity Screws	14–24 mm 2 mm increments	7 mm
	26–36 mm 2 mm increments	10 mm
4.0 mm Extremity Screws	38–42 mm 2 mm increments	13 mm
	14–24 mm 2 mm increments	7 mm
	26–36 mm 2 mm increments	10 mm
	38–42 mm 2 mm increments	13 mm

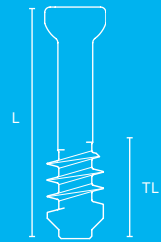

**Lisfranc Injury Fixation**  
Extremity screws used in fixation of a Lisfranc injury to the midfoot

2.7 mm Extremity Screws



**Cannulated Screws**  
Screws are cannulated in order to be used over a guide wire

**Cancellous Threads**  
Each screw is partially threaded using a cancellous thread form

**Streamlined Design**  
Cutting flutes are designed for self-cutting and self-tapping

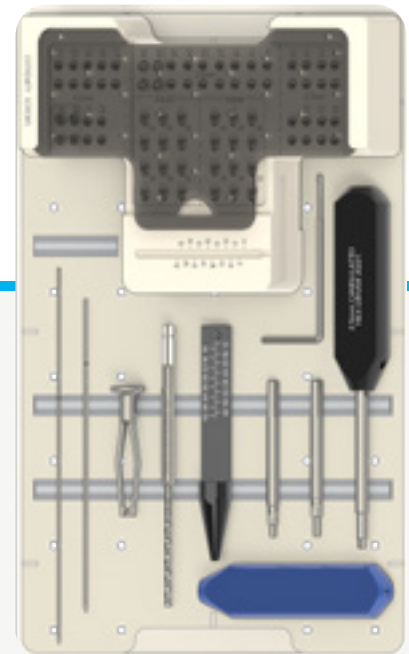

3.5 mm Extremity Screws



4.0 mm Extremity Screws

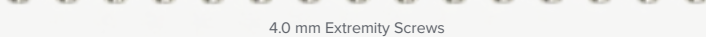



**Screw Length Options**  
Screw lengths from 10–72 mm address a large variety of fracture patterns

**Low-Profile Head**  
Screw head is designed to reduce soft-tissue irritation when compared to standard screw heads

**Cancellous Thread Form**  
Designed to maximize purchase in cancellous bone

**Screw Tip**  
Screws feature cutting flutes for self-drilling and self-tapping



**TripleTwist™ Cannula**  
Modular cannula system features intuitive locking mechanism. Cannulas are stacking and interchangeable to streamline procedures



**Parallel Wire Guide**  
Allows flexible and reproducible placement of parallel guide wires. Optimal distance of wires can be selected before or after initial wire placement

  
Cannulated Screw Washer

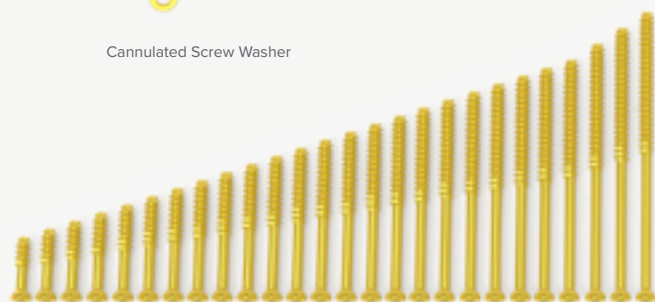

4.0 mm Partially Threaded Short – 1/3 Thread



4.0 mm Partially Threaded Long – 1/2 Thread

## 4.0 mm Cannulated Screw System

The 4.0 mm Cannulated Screw System is designed to provide a minimally invasive method of anatomical fixation. The 4.0 mm screws are available in lengths ranging from 10–72 mm as well as one-half and one-third length threads to accommodate various indications and patient anatomy. Designed to be implanted over a guide wire, the cannulated screws are intended for minimally invasive percutaneous insertion.

4.0 mm Cannulated Screw	Length	Threaded Length
4.0 mm Short Thread	10–60 mm 2 mm increments	1/3 Threaded
4.0 mm Short Thread	60–72 mm 4 mm increments	1/3 Threaded
4.0 mm Long Thread	16–60 mm 2 mm increments	1/2 Threaded
4.0 mm Long Thread	60–72 mm 4 mm increments	1/2 Threaded

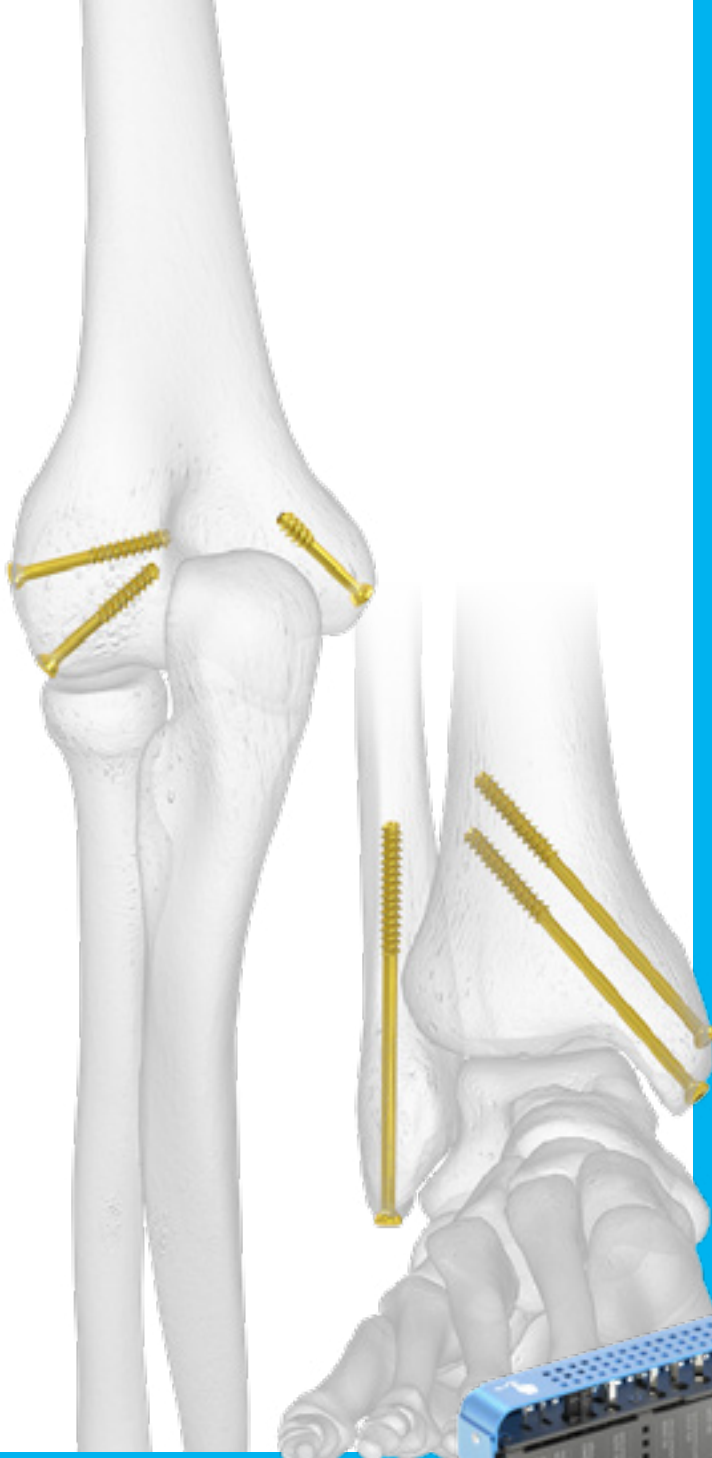
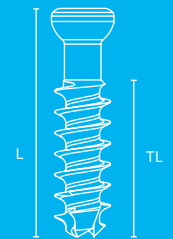

### Locking Flip-Up Caddy

Integrated locking feature holds core instruments and is designed for stability on the back table

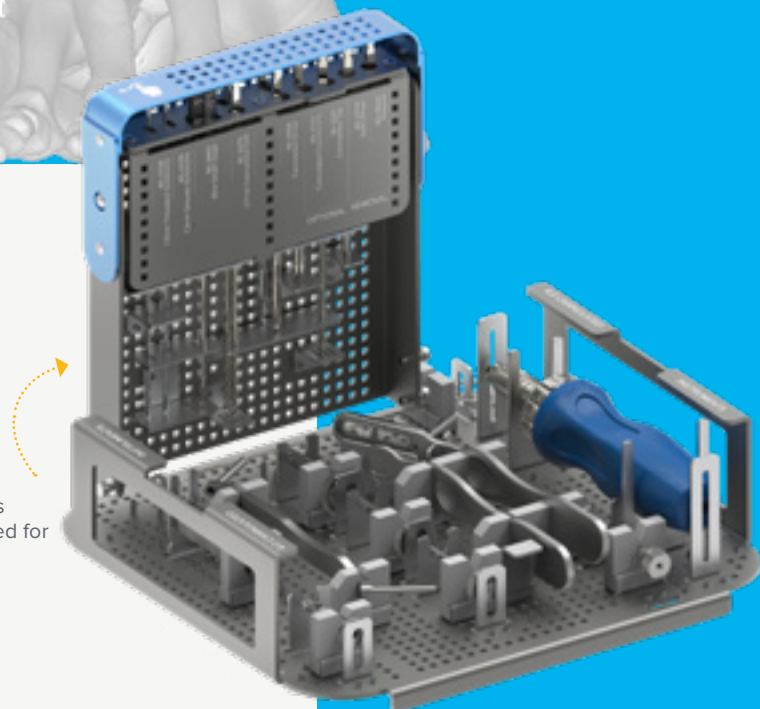

## ExtremiFix™ Cannulated Screw System Midsize | Large Cannulated

The OsteoMed® ExtremiFix Cannulated Screw System | Midsize & Large is indicated for use in bone reconstruction, osteotomy, arthrodesis, and fracture fixation of foot, ankle, and long bones (upper and lower extremity). Screws in the system are offered in three diameters: 4.5 mm, 5.5 mm, and 6.5 mm to accommodate various fracture patterns and patient anatomy.

Headless Screws	Length
4.5 mm Headless Short Thread Screws	20–50 mm (2 mm increments) 55–70 mm (5 mm increments)
4.5 mm Headless Long Thread Screws	40–50 mm (2 mm increments) 55–70 mm (5 mm increments)
5.5 mm Headless Short Thread Screws	20–50 mm (2 mm increments) 55–80 mm (5 mm increments)
5.5 mm Headless Long Thread Screws	40–50 mm (2 mm increments) 55–80 mm (5 mm increments)
6.5 mm Headless Short Thread Screws	40–120 mm (5 mm increments)
6.5 mm Headless Long Thread Screws	45–120 mm (5 mm increments)

Headed Screws	Length
4.5 mm Headed Short Thread Screws	20–50 mm (2 mm increments) 55–70 mm (5 mm increments)
4.5 mm Headed Long Thread Screws	40–50 mm (2 mm increments) 55–70 mm (5 mm increments)
5.5 mm Headed Short Thread Screws	20–50 mm (2 mm increments) 55–80 mm (5 mm increments)
5.5 mm Headed Long Thread Screws	40–50 mm (2 mm increments) 55–80 mm (5 mm increments)

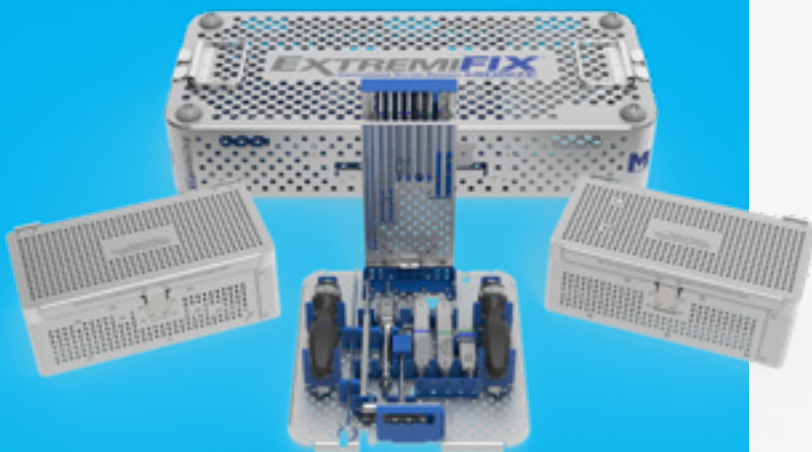

### Modular Tray Configurations

Designed as a modular storage system. Each module includes a complete set of instrumentation specific to the screw diameter



**Screw Options**

Offers screws in 4.5 mm, 5.5 mm, and 6.5 mm thread diameters to accommodate various fracture patterns and patient anatomy



**Self-Retaining Hexalobe Drive Recess T15, T30**  
Ease of use and higher torque resistance



**Double-Lead Screws**

The double lead thread design and Hexalobe driver allows for faster screw insertion and higher torque resistance without compromising the strength of the screw



**Controlled Compression**

A dedicated reduction tool is designed to control compression and countersinking of headless screws using a lag technique

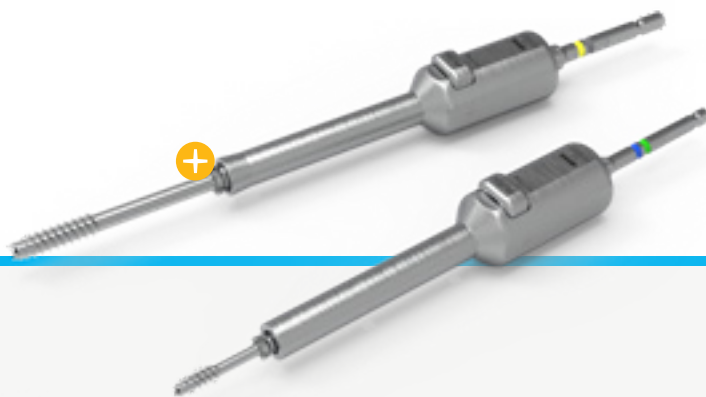

6.5 mm Cannulated Screws



5.5 mm Cannulated Screws



4.5 mm Cannulated Screws

## 6.5 & 7.3 mm Cannulated Screw System

The Acumed Cannulated Screw System is intended for fixation of fractures, fusions, and osteotomies of large and small bones appropriate for the size of the device. All screws are cannulated in order to be used over a guide wire. Each screw is partially or fully threaded using a cancellous thread form.

6.5 mm Cannulated Screw	Length	Threaded Length
6.5 mm Short Thread	30–150 mm 5 mm increments	16 mm Thread
6.5 mm Long Thread	45–150 mm 5 mm increments	32 mm Thread
6.5 mm Full Thread	30–150 mm 5 mm increments	Full Thread

7.3 mm Cannulated Screw	Length	Threaded Length
7.3 mm Short Thread	30–150 mm 5 mm increments	16 mm Thread
7.3 mm Long Thread	45–150 mm 5 mm increments	32 mm Thread
7.3 mm Full Thread	30–150 mm 5 mm increments	Full Thread

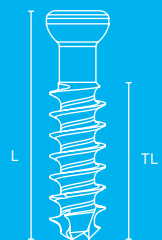
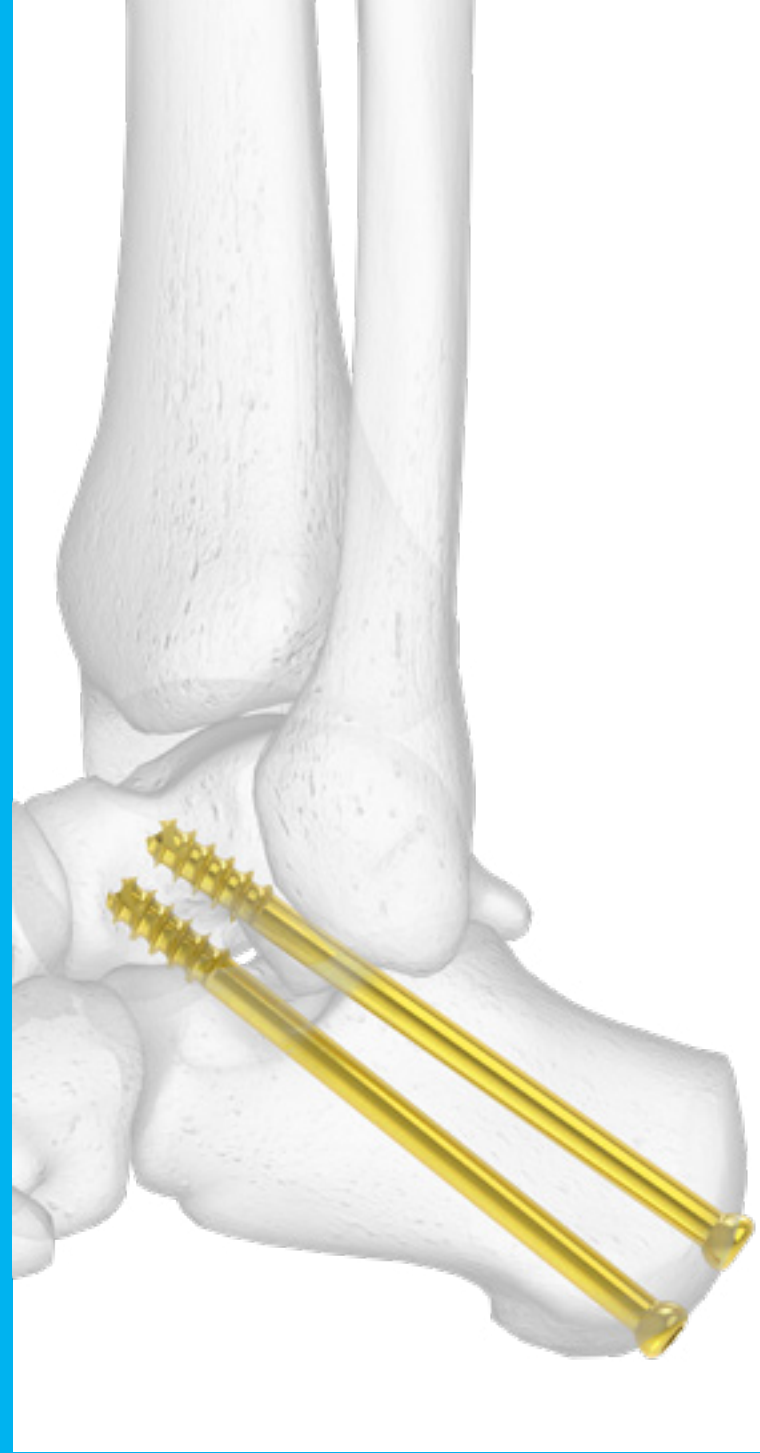

### 6.5 mm Screw Applications

These include ankle arthrodesis, humeral head fractures, olecranon fractures, and distal humerus fractures

### 7.3 mm Screw Applications

These include femoral neck and head fractures, acetabular fractures, and sacroiliac joint disruption

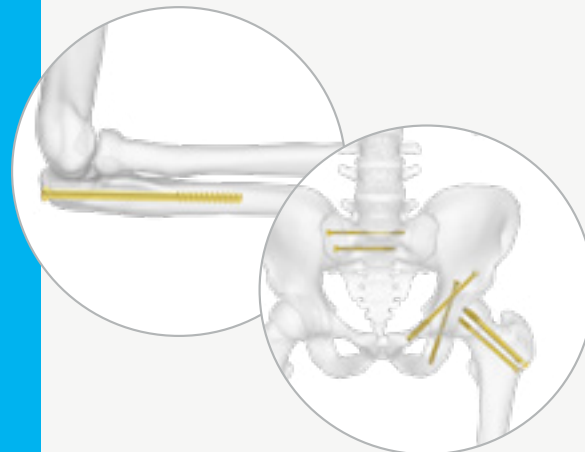

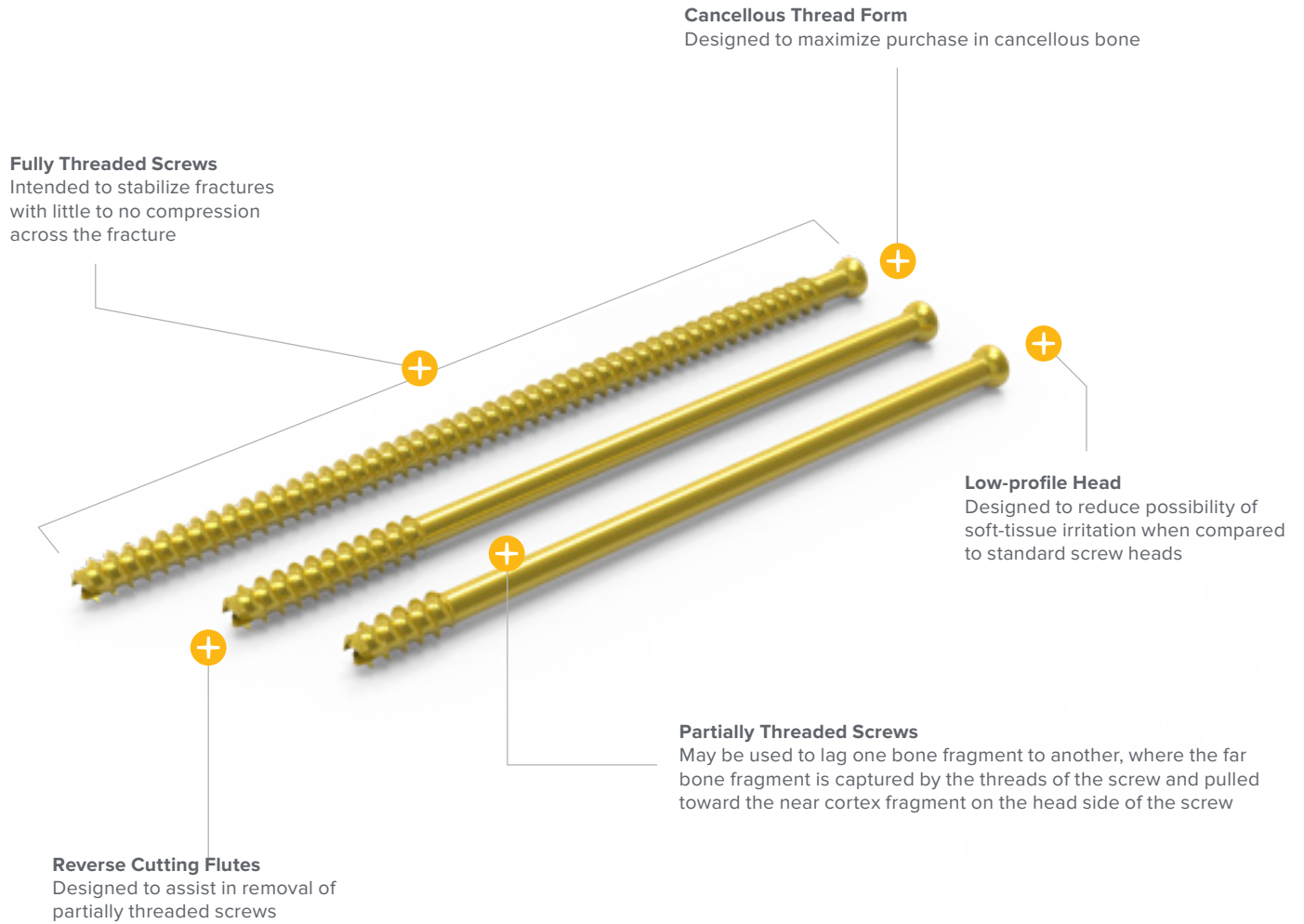

## InstaFix™ Shape Memory Fixation System

The OsteoMed® InstaFix Shape Memory Fixation System is a body-temperature activated shape memory fixation system indicated for arthrodesis, osteotomies, and skeletal fixation procedures. The use of nitinol, a shape memory alloy, allows InstaFix to provide continuous and active bicortical compression at the surgical site. Staples can be used in applications for upper and lower extremities.

InstaFix	Backspan	Leg Length	Wire Size
1.5 mm InstaFix	8 mm	8 mm	1.2 mm
2.0 mm InstaFix	10 mm	10 mm	1.5 mm
2.0 mm InstaFix	15 mm	10 mm	1.5 mm
2.0 mm InstaFix	10 mm	15/17 mm	1.5 mm
2.0 mm InstaFix	15 mm	15/17 mm	1.5 mm
3.5 mm InstaFix	20 mm	15 mm	3 x 2 mm
3.5 mm InstaFix	20 mm	20 mm	3 x 2 mm
3.5 mm InstaFix	25 mm	20 mm	3 x 2 mm
3.5 mm InstaFix	30 mm	20 mm	3 x 2 mm

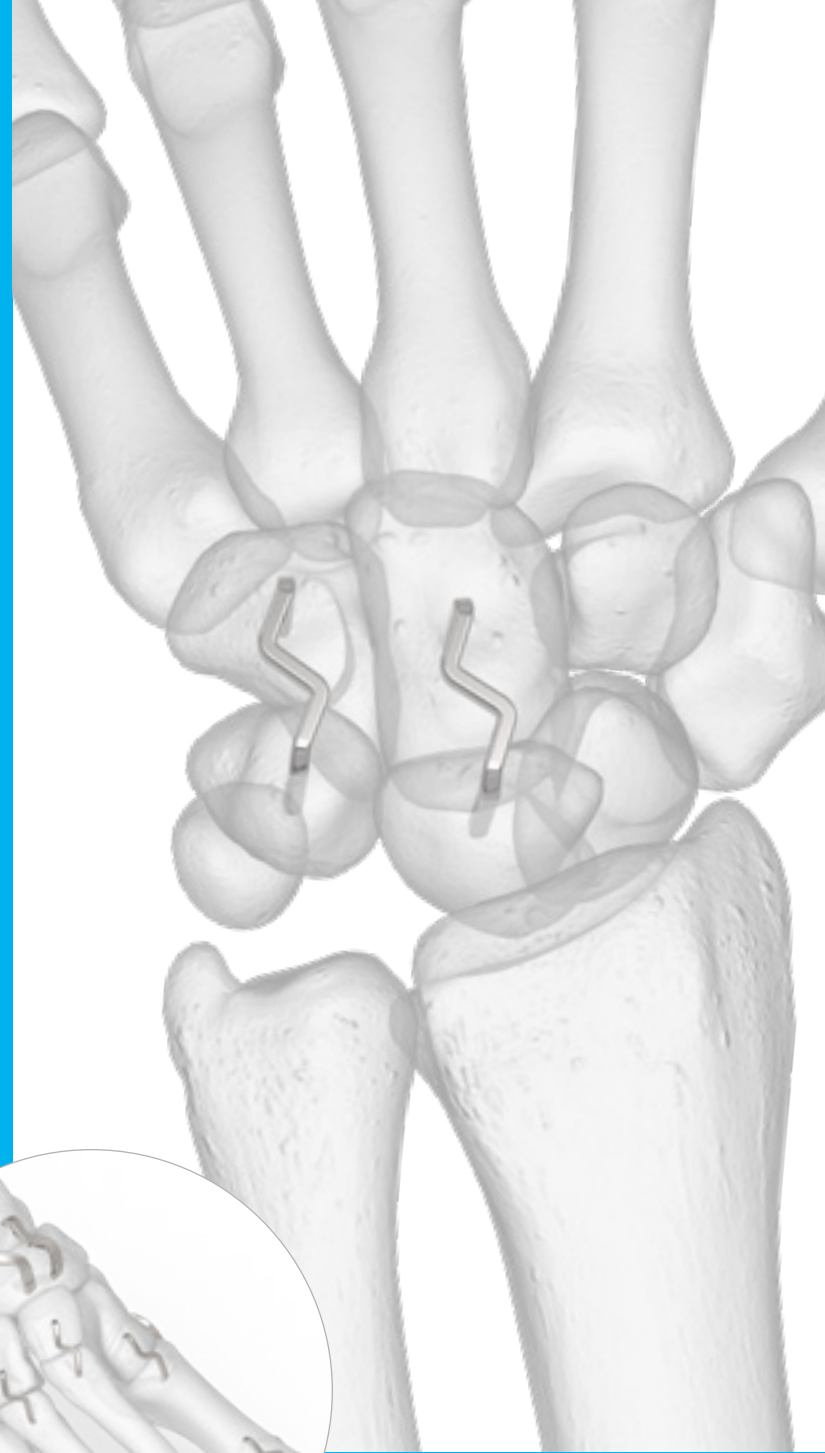
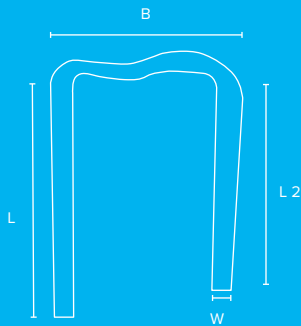

**Patented Ergonomic System**  
Facilitates a simple procedure with an in-line drill guide that maximizes visualization during drilling, staples preloaded on an exclusive inserter with an integrated tamp, and a sliding window mechanism to insert the implant



**Low-Profile Design**  
Helps minimize tissue disruption

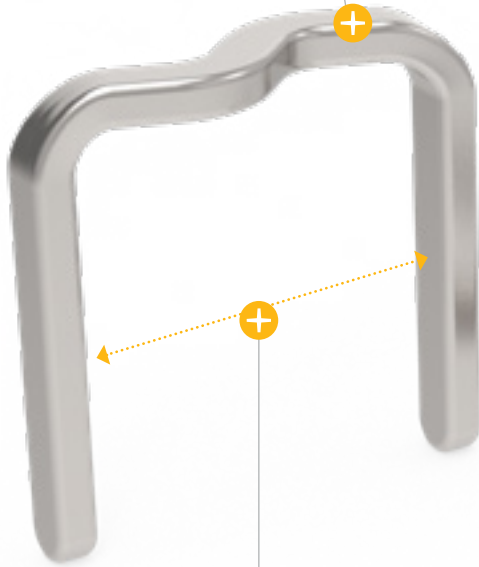

**Shape Memory Alloy**  
Nitinol, a biocompatible shape memory alloy, allows dynamic continuous compression of the InstaFix staple upon reaching body heat

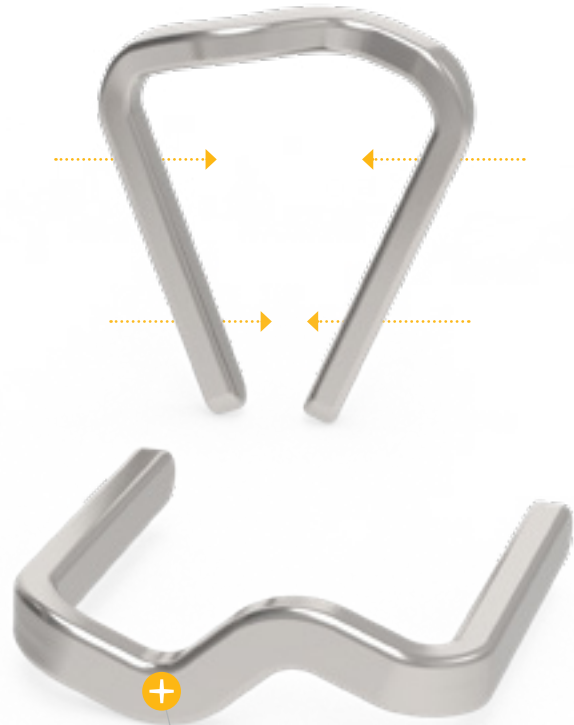

**Bicortical Compression**  
S-back design provides continuous and active bicortical compression at surgical site



**Multiple Sizes**  
Nine distinct sizes for arthrodesis, osteotomies, and other skeletal fixation procedures

**Low-Profile Head**

The low-profile head is designed to minimize soft-tissue irritation

**Secure Anchoring**

Cerclage wire passes through the eyelet of the pin, a feature implemented for fracture reduction and secure anchoring designed to deter postoperative migration of pin

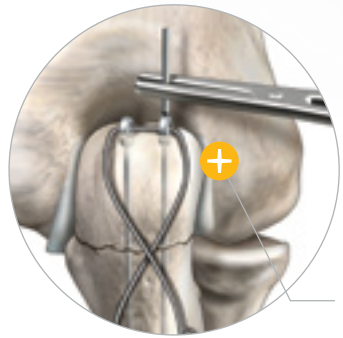

**Straightforward Application**

Point-and-drill pin placement. Tail can be broken with Tension Band Pin Snapper or forceps



50 mm Tension Band Pin

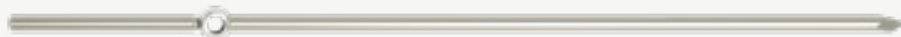

70 mm Tension Band Pin



90 mm Tension Band Pin



## Tension Band Pin System

The Acumed Tension Band Pin System is an interlocking solution designed to provide low-profile, secure fixation for patella, olecranon, and malleolar fractures. The system features straightforward application of a stainless steel pin that is secured by passing a cerclage wire through an eyelet on its proximal end. This feature was designed to help deter migration of the pin postoperatively.

Tension Band Pins	Length	Diameter
Tension Band Pin	50 mm	1.6 mm
Tension Band Pin	70 mm	1.6 mm
Tension Band Pin	90 mm	1.6 mm

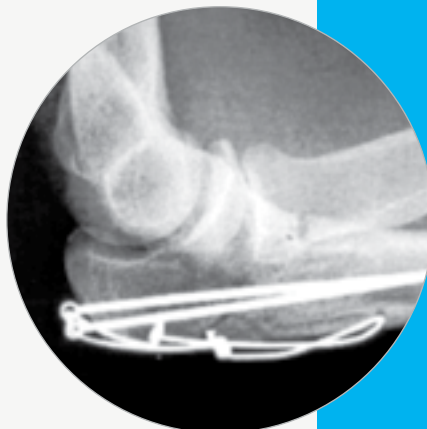
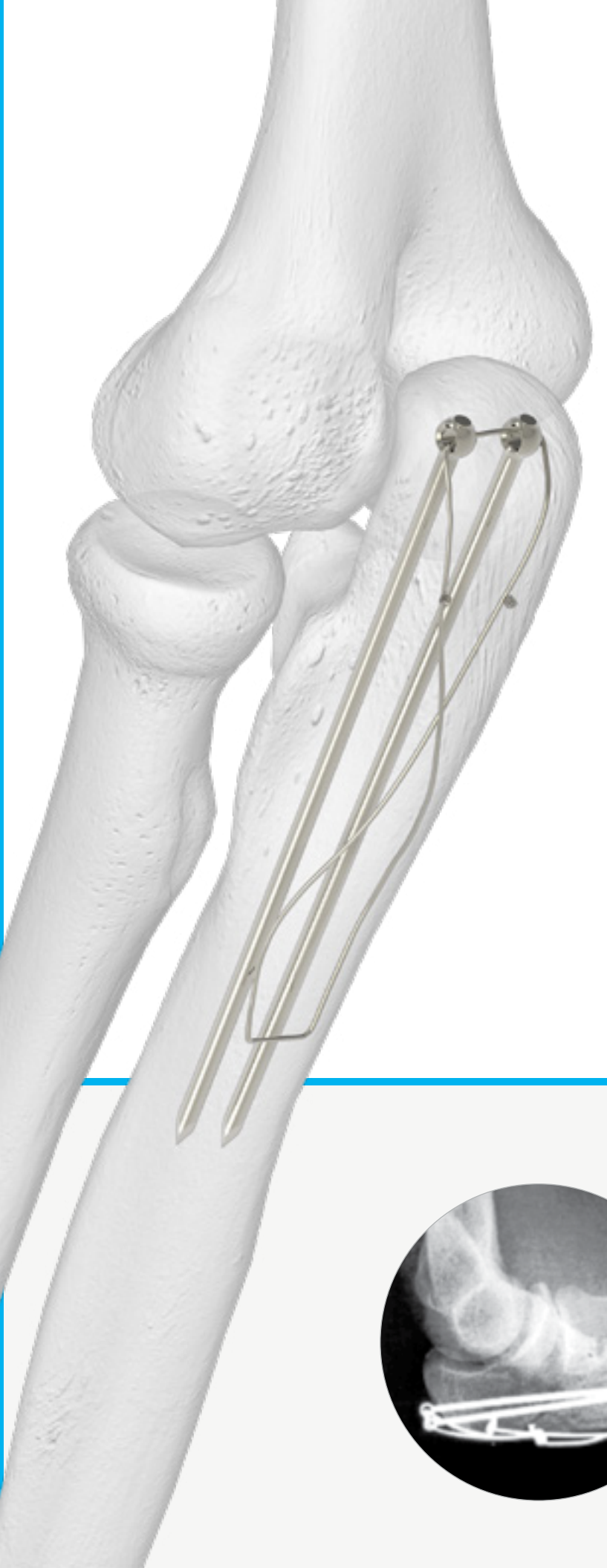

**Olecranon Osteotomy**  
Tension Band Pin System used in an olecranon osteotomy

## Inion FreedomPin®

The resorbable Inion FreedomPin distributed by OsteoMed® is indicated for maintenance of alignment and fixation of bone fractures, osteotomies, digital arthrodesis, or bone grafts with additional immobilization (e.g. implants, cast, brace). The system offers four different diameters: 1.5 mm, 2.0 mm, 2.7 mm, and 3.2 mm, and can be cut to accommodate various fracture patterns and patient anatomy.

Pins	Length
1.5 mm FreedomPin	50 mm
2.0 mm FreedomPin	50 mm
2.7 mm FreedomPin	50 mm
3.2 mm FreedomPin	50 mm



### Multiple Indications

Used for alignment and repair of hand, wrist, foot, and ankle bone fractures



**Biodegradable Resorbable Pins**

Made from a copolymer blend material designed for a variety of alignment and fixation indications in conjunction with additional immobilization

**Cut to Size**

Available in four different diameters (1.5 mm, 2.0 mm, 2.7 mm, and 3.2 mm) for a variety of applications

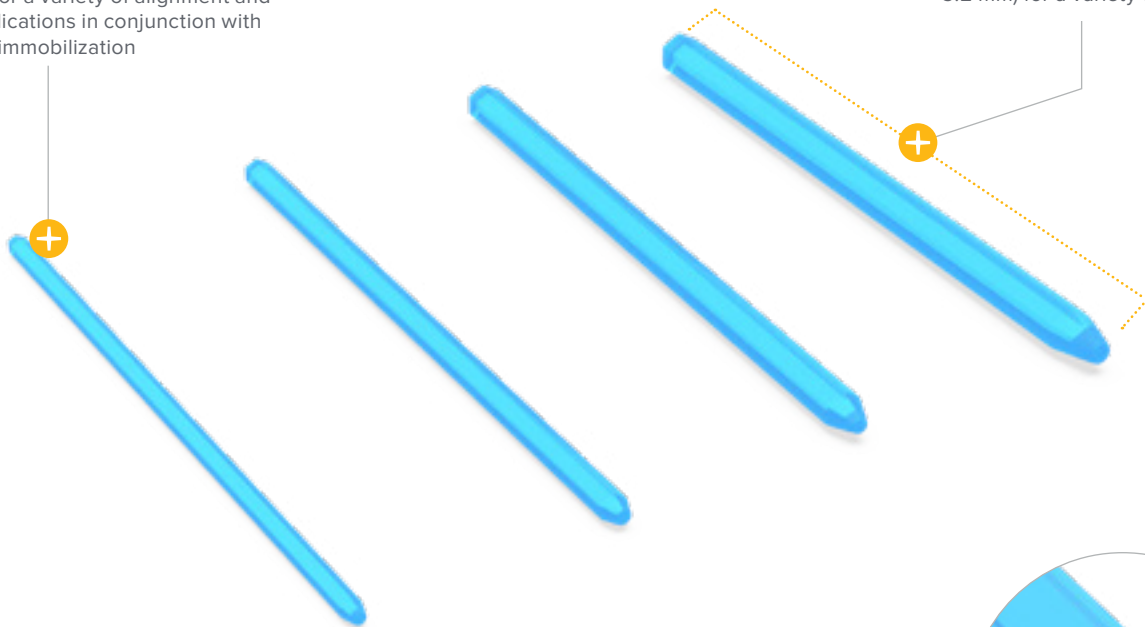

**Hexagonal Shaft Shape**

Provides significant improvement to the rotational and pullout stability of the implant with stable fixation

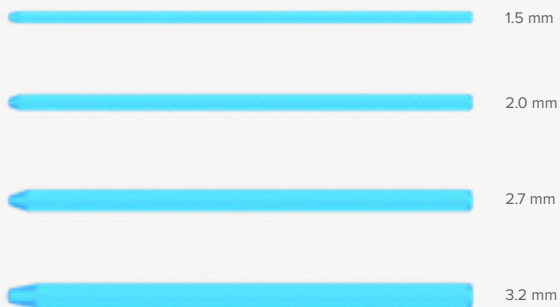

All-in-One Sterile Kit

**Biodegradable Pins**

Composed of a proprietary blend of L-lactide, D, L-lactide, and trimethylene carbonate (TMC) designed to retain full strength throughout 12 weeks and completely absorb within 2–4 years

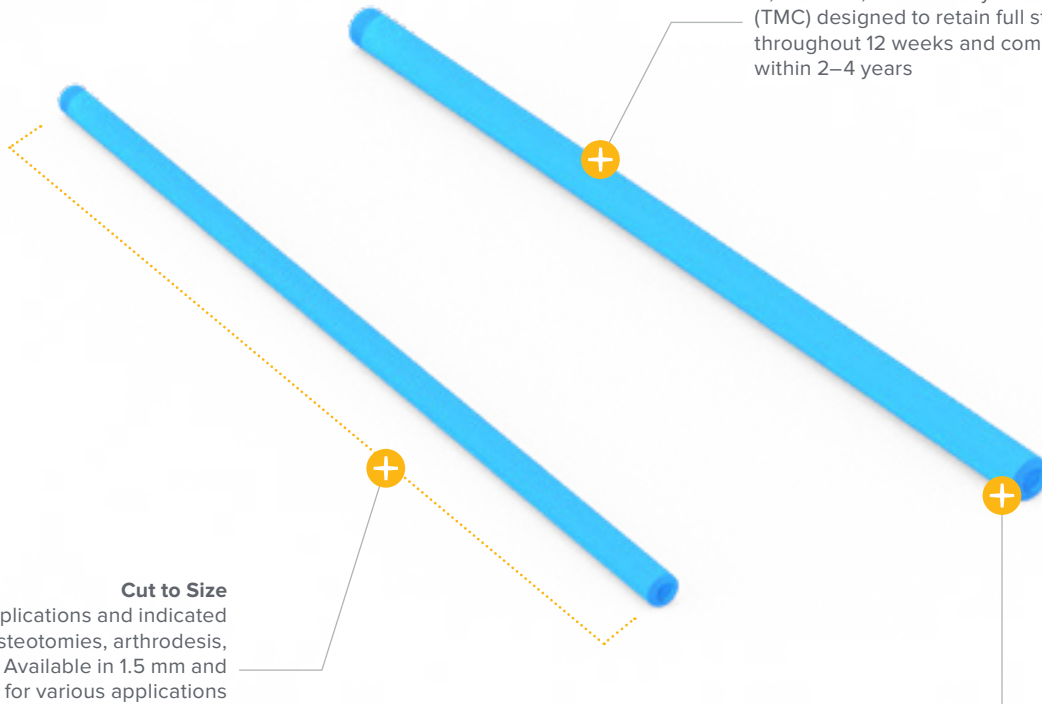

**Cut to Size**

For a variety of applications and indicated for fractures, osteotomies, arthrodesis, and bone grafts. Available in 1.5 mm and 2.0 mm diameters for various applications and can be cut to accommodate diverse patient anatomies

**Radiolucent Pin**

Provides surgeon with unimpeded radiographic visualization



## Inion OTPS™ Pins

The Inion OTPS Pins distributed by OsteoMed® are indicated for maintenance of alignment and fixation of bone fractures, osteotomies, digital arthrodesis, or bone grafts with appropriate additional immobilization (e.g. implants, cast, brace). The resorbable pins are offered in two diameters: 1.5 mm and 2.0 mm, and can be cut to accommodate various fracture patterns and patient anatomy.

Pins	Length
1.5 mm OTPS Pin	50 mm
2.0 mm OTPS Pin	50 mm

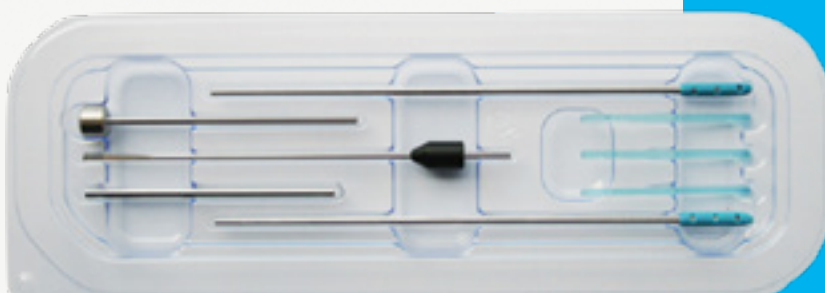
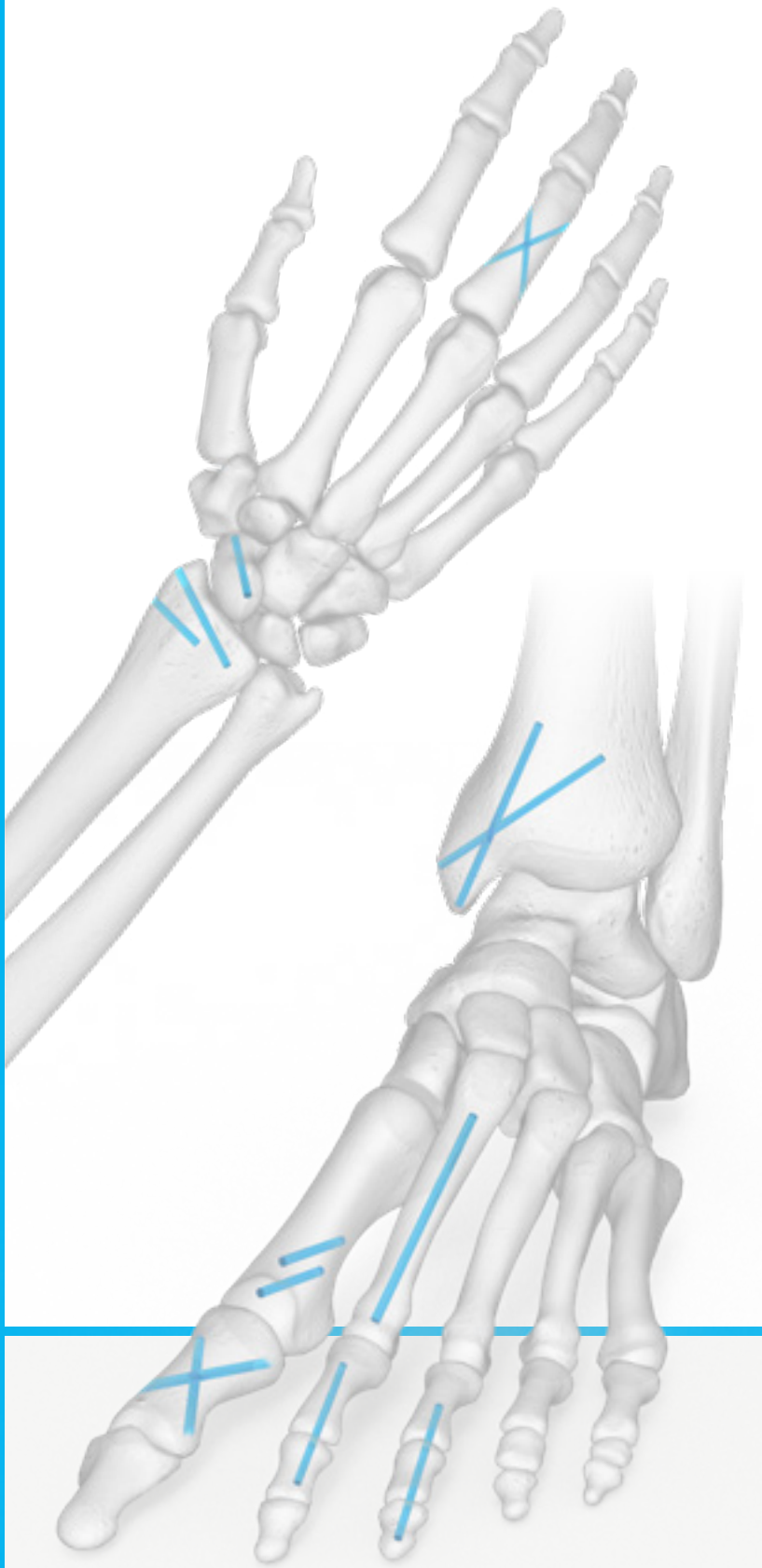

### All-In-One Sterile Kit

Single-use sterile pins and instrumentation option provide surgeon with a convenient all-in-one kit, eliminating preoperative sterilization

## OR Essentials Kit

The OR Essentials Kits, including single-use sterile-packed drill bits, guide wires, drivers, reamers, and easyouts, are now available in the United States. These product configurations, including base and full sets for upper and lower extremity surgeries, were designed as consignment stock for surgeons who prefer a fresh drill bit or guide wire.

### Upper Extremities Base Kit

.035 x 6 in Trocar Guide Wire	Single & Double
ST Guide Wire	.035" x 5.75", .045" x 6", .054" x 7"
Plate Tack	
Quick Release Drill	2.0, 2.8, 2.3 mm, 3.0 mm x 5", 1.1 mm x 3.5", 3.5 mm x 5"
Frag-Loc 2.5 mm Drill	
Acutrak 2 Drills	Micro, Micro Extended, Long, Mini, Mini Long,
Bone Graft Drill Assembly	7 mm

### Additional Upper Extremities Instruments

Concave MTP Reamer	10, 12, 14, 16 mm
Convex MTP Reamer	10, 12, 14, 16 mm
Easyout, Quick Release	1.5, 2.0, 2.5 mm
Cann. Quick Release Driver Tip	1.5, 2.0, 2.5 mm

### Lower Extremities Base Kit

Guide Wire	.062" (1.6 mm) x 9.25", .094" (2.4 mm) x 9.25", .094" (2.4 mm) x 9.25" Thrd., .045" x 6"
Plate Tack	
Quick Release Drill	2.8, 2.3 mm, 3.0 mm x 5", 3.5 mm x 5"
Acutrak 2 Drill	4.7 Profile, 4.7 Long, 5.5 Profile Large AT2, 5.5 AT2 Long Large 7.5 Profile, 7.5 Long

### Additional Lower Extremities Instruments

Concave MTP Reamer	14 & 16 mm
Convex MTP Reamer	14 & 16 mm
Easyout, Quick Release	2.0, 2.5, 3.0, 4.0 mm

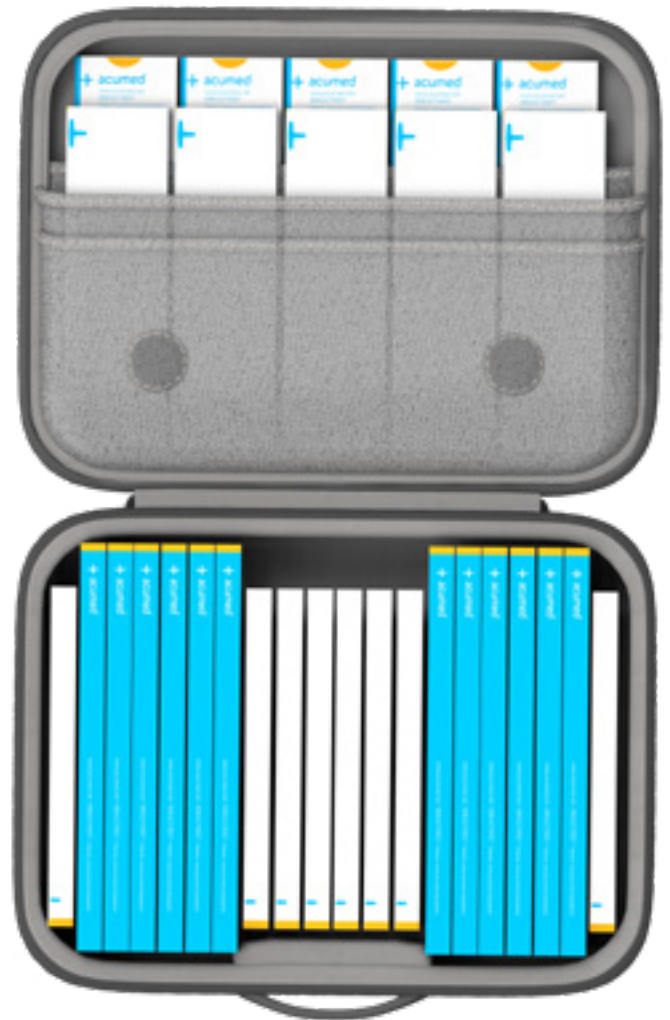

Guide Wires

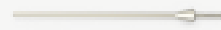

Plate Tack



7 mm Bone Graft Drill Assembly



Concave MTP Reamer

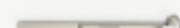

Convex MTP Reamer

**Upper Extremities Kit**

Base and full kits support parts from Acutrak 2®, Hand Fracture System, Modular Hand, Acu-Loc® 2, Elbow Plating, Anatomic Radial Head Systems, and more



**Lower Extremities Kit**

Base and full kits support parts from the Lower Extremity Modular System, Calcaneus Plates, Ankle Plating System 3, Small Fragment Base Set, and more



**Shell-Case Custom Bags**

Acumed-branded bags weigh an ultralight 2 to 2.4 lbs, and include a shoulder strap, handle, and a divider organizing parts in the lid compartment

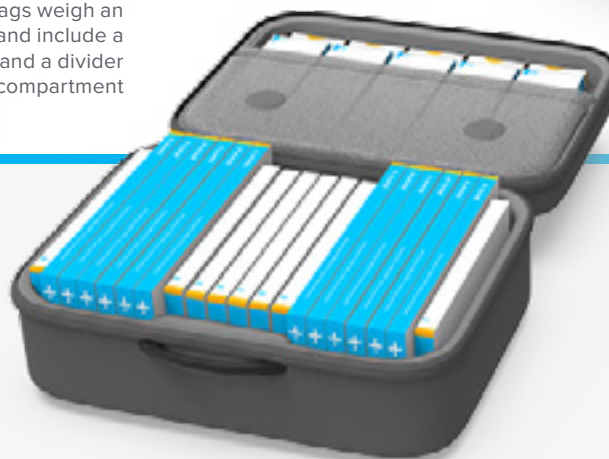

Quick Release Drill



Cann. Quick Release Driver Tip



Frag-Loc 2.5 mm Drill



Acutrak 2 Drill



Easyout Quick Release Drill

**Screw Options**

Screw lengths from 40–120 mm address a large variety of procedures and patient anatomy

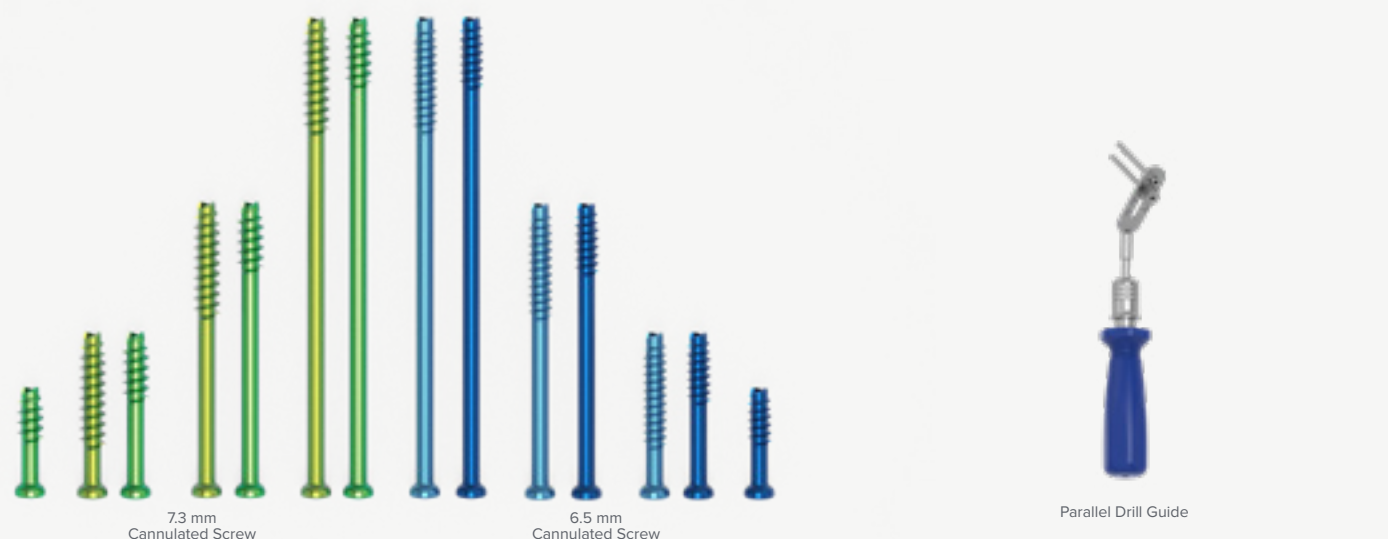



## Large Cannulated Screws

The OsteoMed® Large Cannulated Screw System offers 6.5 mm and 7.3 mm screws and washers for bone fixation following a trauma or osteotomy. A wide range of screw lengths are available with both 20 mm and 32 mm thread lengths to accommodate multiple procedures and patient anatomy.

6.5 mm Cannulated Screw	Length	Threaded Length
-------------------------	--------	-----------------

6.5 mm Short Thread	40–120 mm 5 mm increments	20 mm
---------------------	------------------------------	-------

6.5 mm Long Thread	40–120 mm 5 mm increments	32 mm
--------------------	------------------------------	-------

7.3 mm Cannulated Screw	Length	Threaded Length
-------------------------	--------	-----------------

7.3 mm Short Thread	40–120 mm 5 mm increments	20 mm
---------------------	------------------------------	-------

7.3 mm Long Thread	40–120 mm 5 mm increments	32 mm
--------------------	------------------------------	-------



### Thread Choice

20 mm and 32 mm thread lengths available to accommodate multiple procedures and patient anatomy



Percutaneous Guide

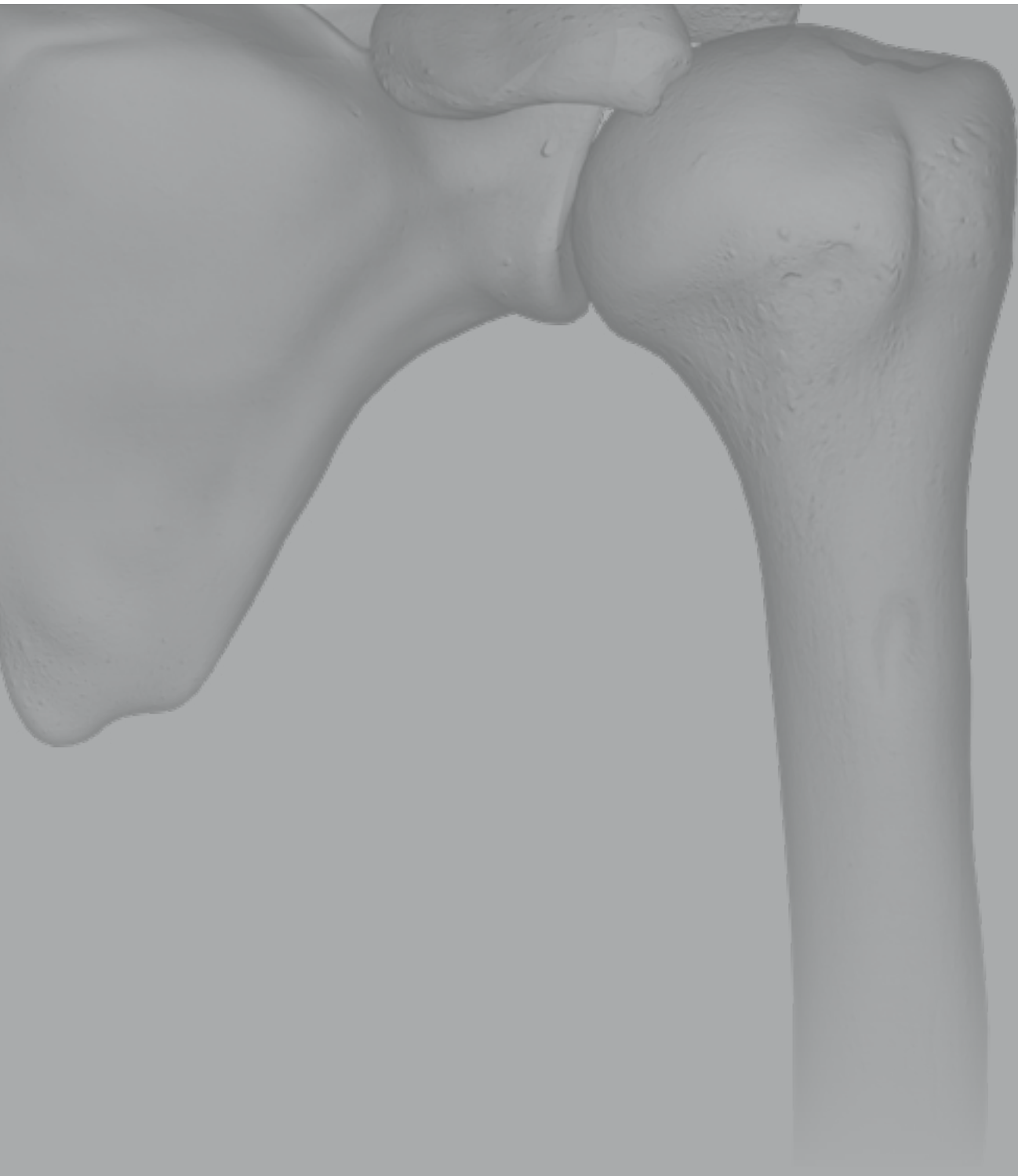



## Shoulder Product Lineup

Clavicle Plating System .....	<b>34</b>
Hook Clavicle Plating System .....	<b>36</b>
Locking Clavicle Plating System .....	<b>38</b>
Dual-Trak Clavicle Screw System .....	<b>40</b>
Polarus® 3 Solution .....	<b>42</b>
Polarus® Proximal Humeral Plating System .....	<b>44</b>
Polarus® Humeral Rod System .....	<b>46</b>
Scapula Plating System .....	<b>48</b>

**Precontoured Plates**

Implants offer left- and right-specific, narrow, and standard offerings with a variety of screw options



**Beveled Edge**

Beveled medial and lateral profile designed to help minimize soft-tissue irritation

**K-wires for Fixation**

Integrated .062" K-wire holes are incorporated for provisional fixation and can be used to verify distal screw placement

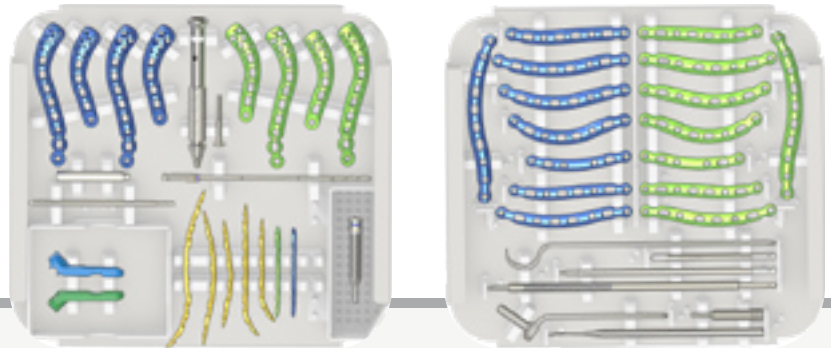

Low-profile

Narrow-profile

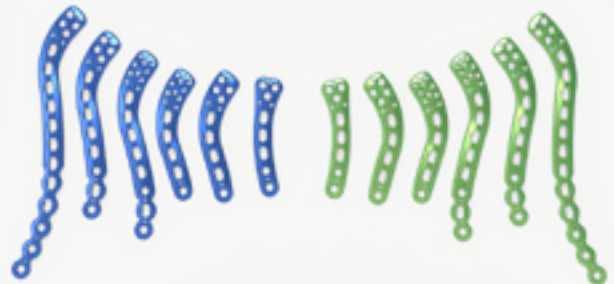
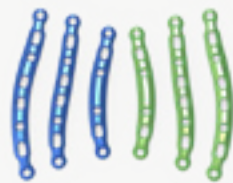
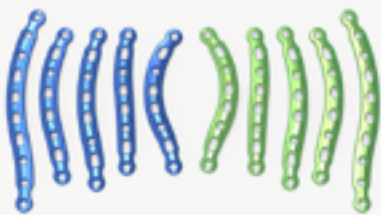

Superior Midshaft Plates

Superior Distal Plates

## Clavicle Plating System

The Acumed Clavicle Plating System offers an array of 33 precontoured plates for the fixation of clavicle fractures, malunions, and nonunions. Acumed's was the first system to offer precontoured plates for the clavicle.

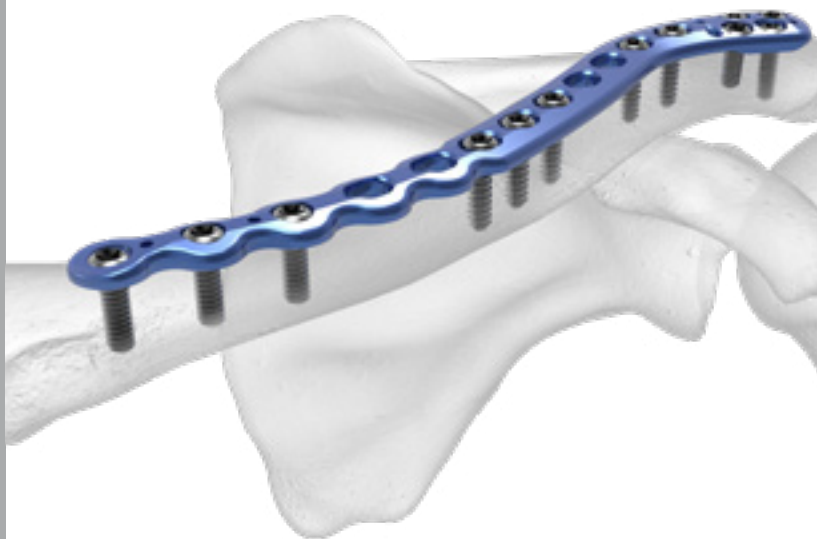

Superior Midshaft Clavicle Plates	Hole Count	Length
Low-Profile Plate, Left & Right	8-hole	87 mm
Low-Profile Plate, Left & Right	8-hole	88 mm
Low-Profile Plate, Left & Right	8-hole	94 mm
Low-Profile Plate, Left & Right	8-hole	98 mm
Low-Profile Plate, Left & Right	10-hole	121 mm
Narrow Profile Plate, Left & Right	6-hole	74 mm
Narrow Profile Plate, Straight, Left & Right	8-hole	87 mm
Narrow Profile Plate, Left & Right	8-hole	96 mm

Superior Distal Clavicle Plates	Hole Count	Length	Distal Cluster Hole Count
Low-Profile J-Plate, Left & Right	8-hole	64 mm	3
Plate, Left & Right	9-hole	68 mm	4
Plate, Left & Right	12-hole	101 mm	4
Plate, Left & Right	13-hole	68 mm	8
Plate, Left & Right	16-hole	101 mm	8
Plate, Left & Right (Sterile Only)	16-hole	140 mm	4

Anterior Clavicle Plates	Hole Count	Length
Lateral Plate	6-hole	75 mm
Medial Plate	6-hole	76 mm
Lateral Plate	8-hole	95 mm
Medial Plate	8-hole	95 mm
Lateral/Medial Plate	10-hole	115 mm

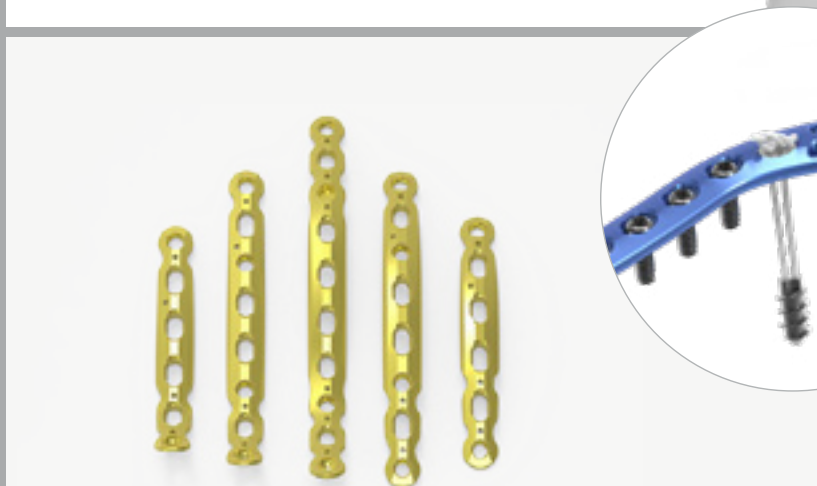

Anterior Plates

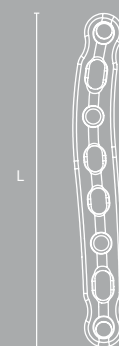

### Acu-Sinch® Repair System

Used with a Superior Midshaft or Distal Clavicle Plate, the sterile-packed system provides fixation during healing of the coracoclavicular ligaments

## Hook Clavicle Plating System

The Acumed Clavicle Hook Plating System is intended to fix lateral clavicle fractures, osteotomies, malunions, nonunions, and dislocations of the acromioclavicular joint. It must be used with the Acumed Clavicle Plating System. The system includes a plate with a hook at the lateral end designed to maintain reduction of the AC joint or distal clavicle fragments.

Clavicle Hook Plates	Plate Length	Hook Depths
5-hole	69 mm	12 mm 16 mm 20 mm
6-hole	80 mm	12 mm 16 mm 20 mm
7-hole	90 mm	12 mm 16 mm 20 mm
*9-hole	111 mm	12 mm 16 mm 20 mm

\*9-Hole Clavicle Hook Plate is offered sterile-packed only

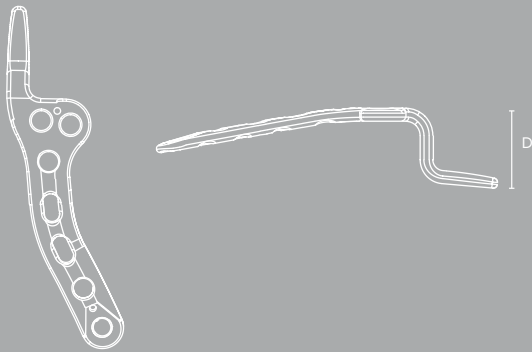

### Innovative Plate Selection Instrumentation

Both hook depth and plate length can be accurately measured with the Plate Depth Sizer and Plate Length Sizer included in the system. The included locking drill guide also acts as a handle for in situ positioning.

**Bend Angulation**  
10° bend in the Clavicle Hook Plate shaft accommodates the inferior angulation of the distal clavicle

**Clavicle Hook Plate**  
Posterior hook placement designed to avoid contact with the rotator cuff and surrounding soft-tissue structures

**Inclined Hook Tip**  
5° inferior inclination of the hook tip designed to help avoid notching on the underside of the acromion



**Minimal Contact**  
Limited contact undersurface may help preserve blood supply to the fracture site

**Three Hook Depths**  
12 mm, 16 mm, and 20 mm



Clavicle Hook Plates

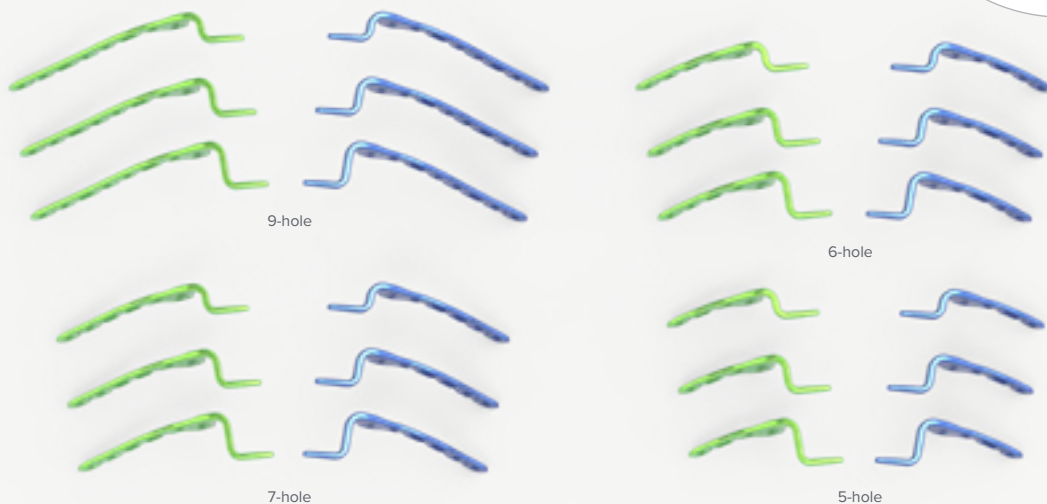



## Locking Clavicle Plating System

The Acumed Locking Clavicle Plating System is designed to treat simple and complex fractures, malunions, and nonunions. The system offers an array of low- and narrow-profile plate solutions, precontoured to match the natural S-shape of the clavicle.

Locking Clavicle J-Plates	Hole Count	Length
J-Plate	8-hole	53 mm
J-Plate	9-hole	66 mm

Superior Midshaft Clavicle Plates	Hole Count	Length
Small Plate, Left & Right	6-hole	75 mm
Straight Plate, Left & Right	8-hole	88 mm
Small Plate, Left & Right	8-hole	87 mm
Medium Plate, Left & Right	8-hole	94 mm
Large Plate, Left & Right	8-hole	98 mm
Large Plate, Left & Right	10-hole	121 mm



The first precontoured clavicle plates on the market

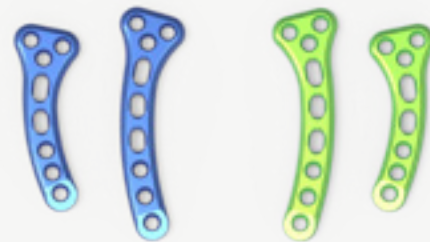

J-Plates

**Holes and Slots**

All plates have a combination of locking holes and compression/reduction slots

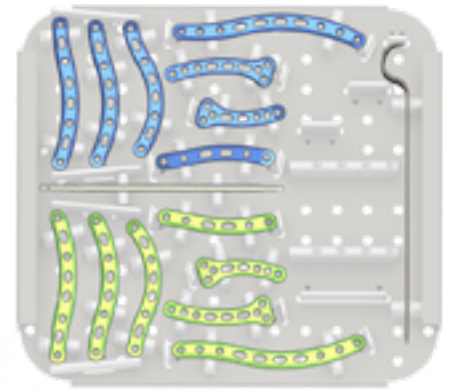

**Low-Profile Design Features**

Tapered plate ends, beveled edges, and a low-profile screw-plate interface help minimize soft-tissue irritation

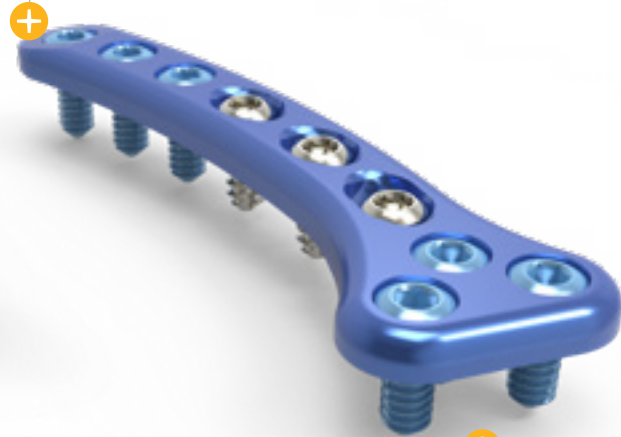
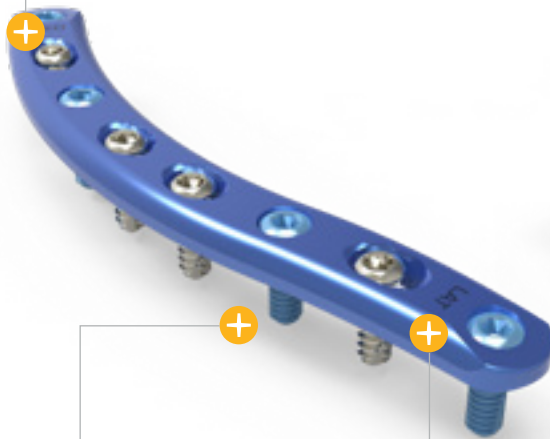

**Laser Marks**

Plates are laser marked to aid in proper orientation

**Tubularized Undersurface**

Designed to allow the plate to sit flush on the bone and provide additional stability, especially in torsion

**Specialized J-plates**

Two J-plates are available for distal/lateral fractures, with a three-hole cluster for increased screw purchase

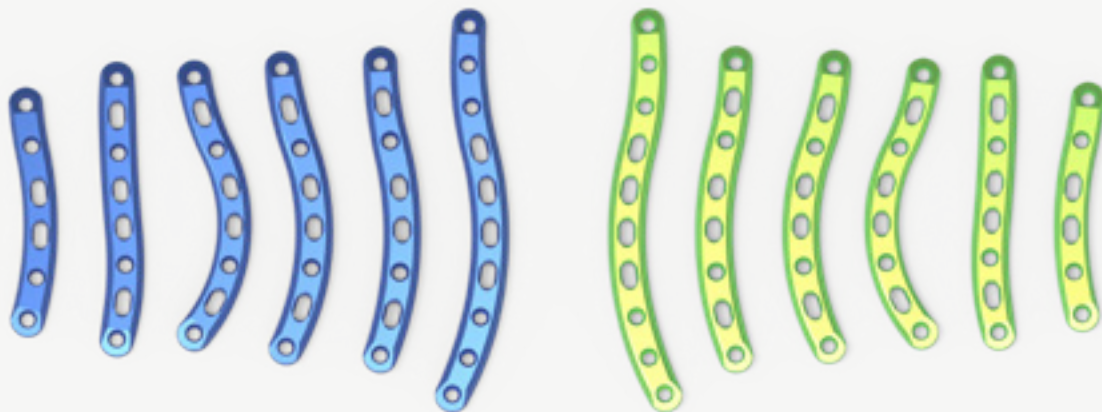

Superior Midshaft Plates

**Choice of Screw Direction**

Screws can be inserted in a lateral to medial or medial to lateral direction, based on surgeon preference and fracture pattern

**Variety of Sizes**

Comprehensive array of screw diameters and lengths provided to accommodate various sizes of patient medullary canals

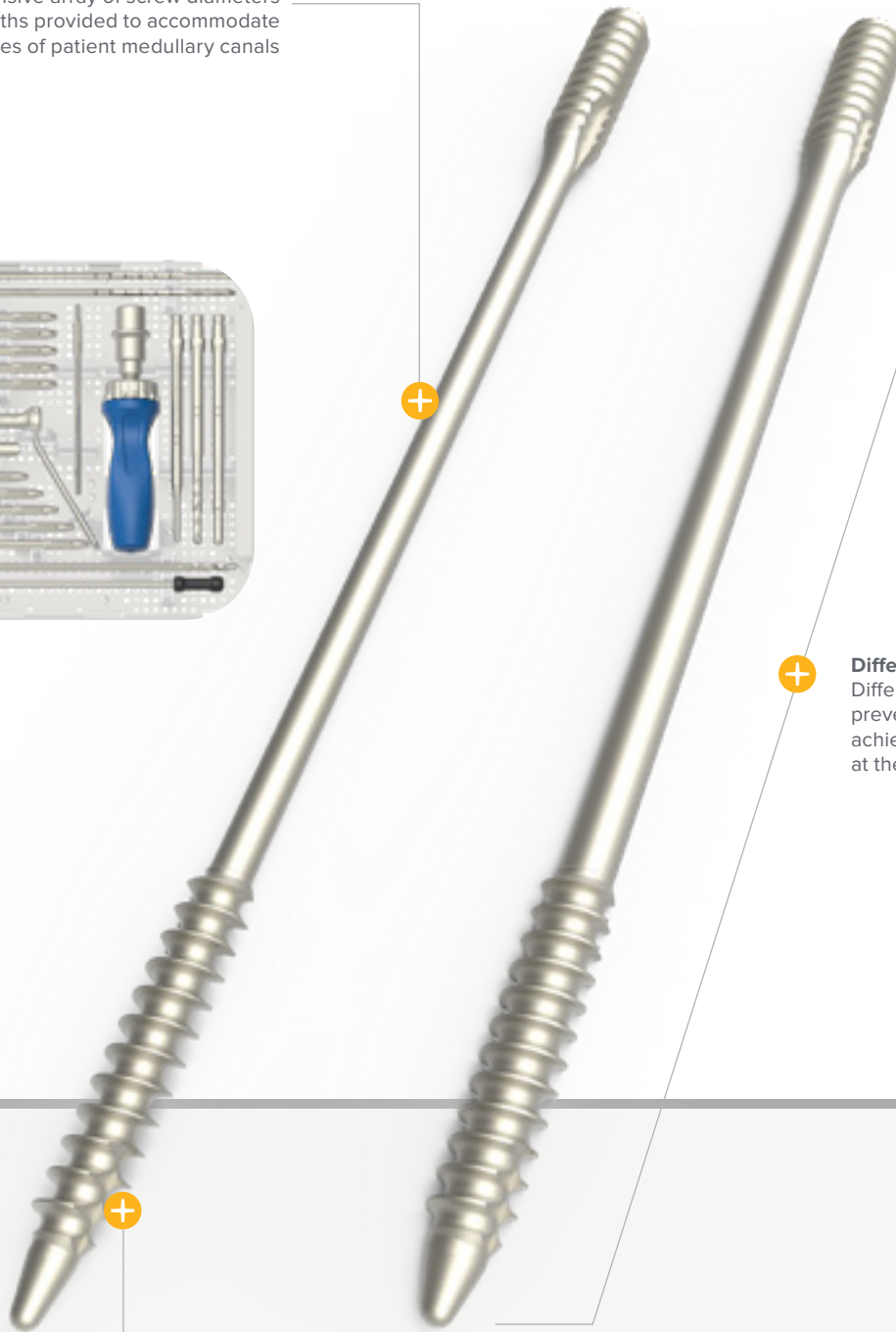

**Differential Pitch on Tip and Tail**  
Differential pitch intended to help prevent implant migration and achieve 0–3 mm of compression at the fracture site

**Cutting Flutes on Tips**  
Cutting flutes are designed to help ease insertion and removal

## Dual-Trak Clavicle Screw System

The Acumed Dual-Trak Clavicle Screw System is a fully intramedullary solution engineered to provide minimally invasive stability for fractures and fusions of the clavicle. The tray design allows it to be placed in the Acumed Clavicle Plating System to expand surgical options.



Dual-Trak Screws	Diameter	Length
Dual-Trak Screw	3.0 mm	80 mm
Dual-Trak Screw	3.0 mm	90 mm
Dual-Trak Screw	3.0 mm	100 mm
Dual-Trak Screw	3.0 mm	110 mm
Dual-Trak Screw	3.0 mm	120 mm
Dual-Trak Screw	3.8 mm	80 mm
Dual-Trak Screw	3.8 mm	90 mm
Dual-Trak Screw	3.8 mm	100 mm
Dual-Trak Screw	3.8 mm	110 mm
Dual-Trak Screw	3.8 mm	120 mm



3.0 mm screws

3.8 mm screws

## Polarus® 3 Solution

The Acumed Polarus 3 Solution is a comprehensive system designed to treat proximal and midshaft humerus fractures with an array of plate and nail options. The system provides numerous improvements to both the implants and the instrumentation compared to the prior generation.



Offers plate and nail in the same system for shoulder fracture fixation



Polarus 3 Proximal Humerus Plates	Hole Count	Length
Standard Plate, Left, Right	4-hole	94 mm
Standard Plate, Left, Right	6-hole	115 mm
Standard Plate, Left, Right	10-hole	155 mm
<b>Opt*</b> Standard Plate, Left, Right	14-hole	195 mm
<b>Opt*</b> Standard Plate, Left, Right	18-hole	235 mm
<b>Opt*</b> Standard Plate, Left, Right	22-hole	275 mm
Posterior Plate, Left, Right	4-hole	94 mm
Posterior Plate, Left, Right	6-hole	115 mm

Polarus 3 Proximal Nail	Length	Distal Diameter
Proximal Locking Nail, Left, Right	150 mm	5.5 mm

Polarus 3 Long Nails	Length	Distal Diameter
Locking Nail	200 mm	8 mm
Locking Nail	220 mm	8 mm
Locking Nail	240 mm	8 mm
Locking Nail	260 mm	8 mm
Locking Nail	280 mm	8 mm

**Note:** The proximal diameter on all nails is 10 mm.

\*Optional, sterile-packed only



**PEEK Insert**  
Pre-assembled insert designed to create proximal locking screw friction



Proximal Locking Nail

Locking Nail



**Posterior Plate Option**  
Bendable tabs are designed to buttress the greater tuberosity

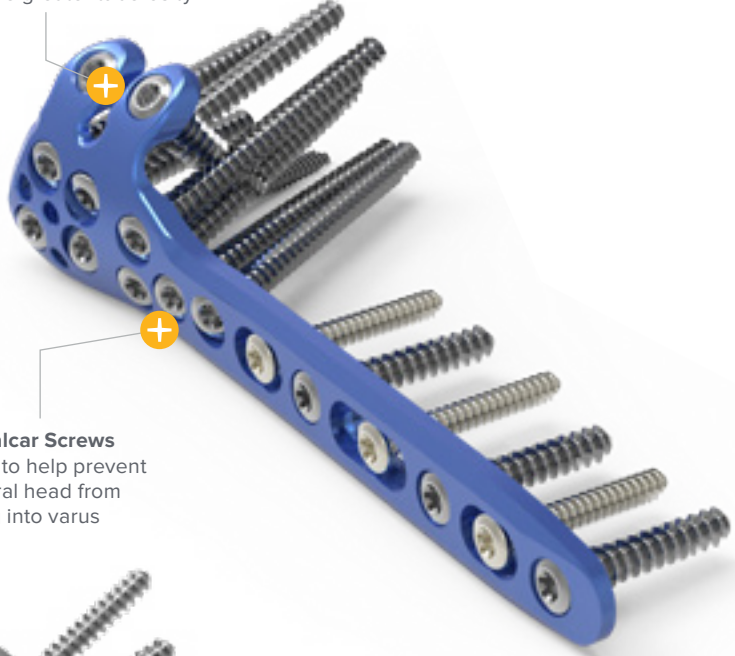

**Medial Calcar Screws**  
Designed to help prevent the humeral head from collapsing into varus

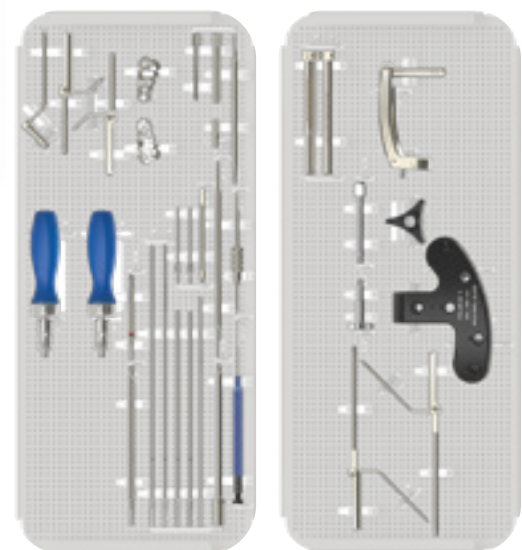

**Slight 4° Curvature**  
Medializes the entry and is designed to facilitate insertion

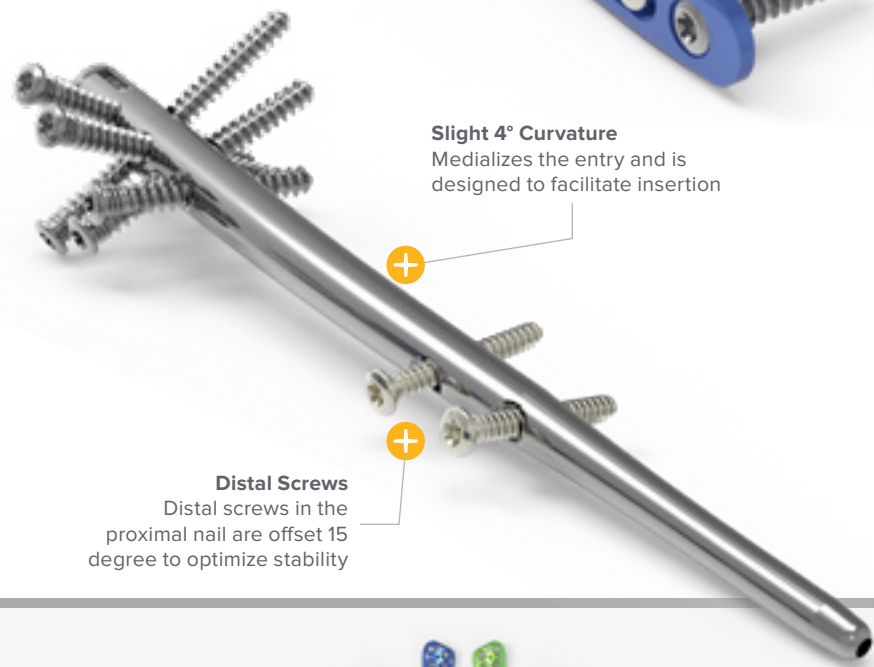

**Distal Screws**  
Distal screws in the proximal nail are offset 15 degree to optimize stability

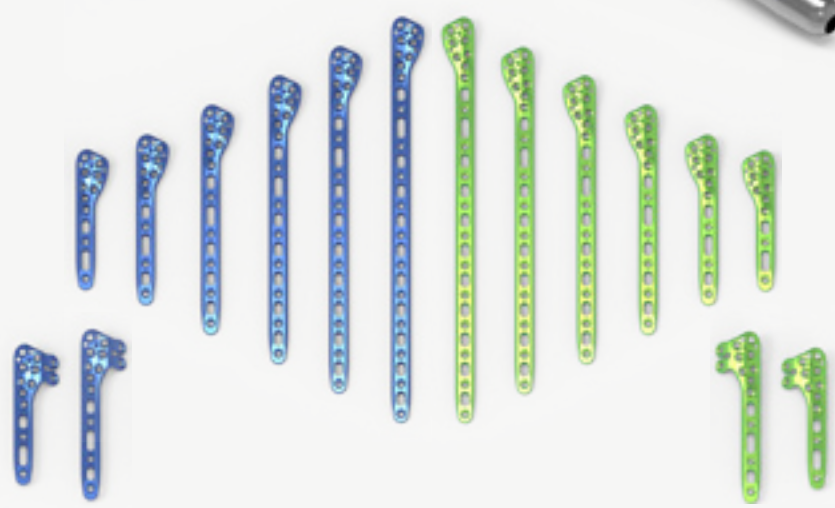
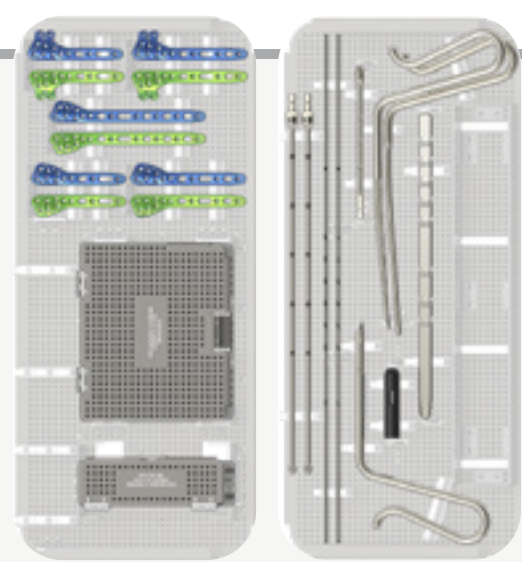

Posterior Plate

Standard Plate

Posterior Plate

**Enhanced Screw Angulation**

Fixed-angle locking screws target the best-quality bone for maximized purchase in the humeral head, creating a solid and stable construct

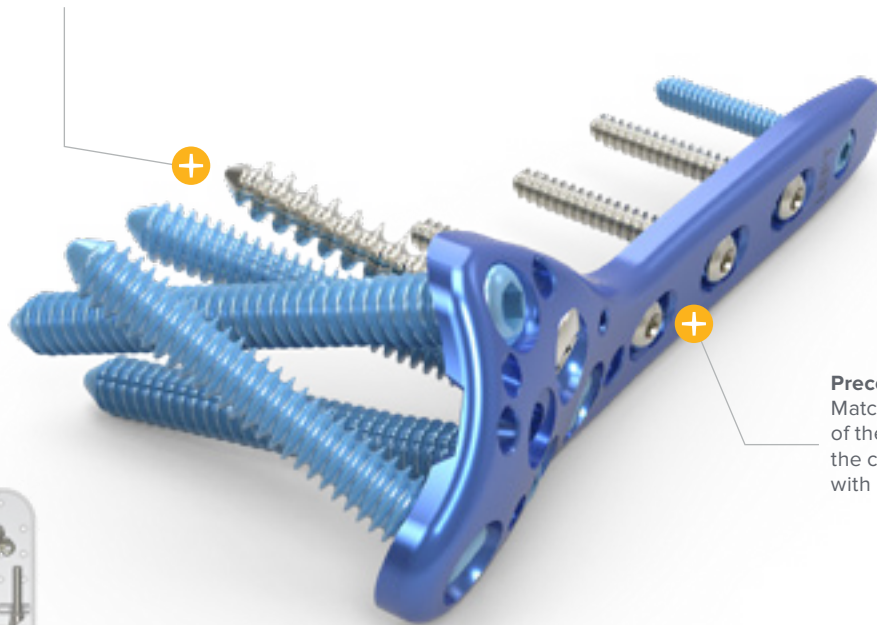

**Precontoured Plate Design**

Matches the anatomical slope of the proximal humerus and the curvature of the tuberosities with minimal bending

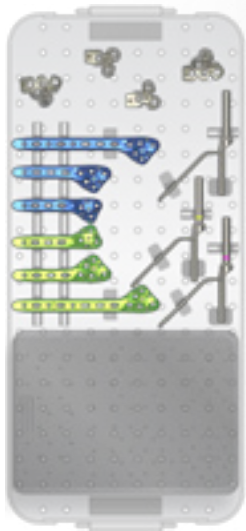

**Suture Hole Cutouts**  
Plates include cutouts to accommodate sutures



Proximal Humeral Plate

## Polarus® Proximal Humeral Plating System

The Acumed Polarus Proximal Humeral Plating (PHP) System, designed for 2-, 3-, and 4-part proximal humerus fractures, aids in restoring patient anatomy while providing a rigid construct within the humeral head. The comprehensive selection of implants was designed to help minimize impingement and soft-tissue irritation.

Polarus Proximal Humerus Plates	Length
Proximal Humeral Plate, Small	93 mm
Proximal Humeral Plate, Large	103 mm
Proximal Humeral Plate, Extra Long	154 mm

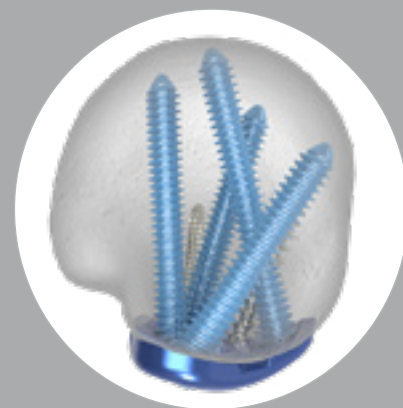

### Fixed-angle Locking Screws

Designed to target the best-quality bone in the humeral head and create a solid and stable construct



## Polarus® Humeral Rod System

The Acumed Polarus Locking Humeral Rod and Polarus Plus Humeral Rod System feature tapered profiles with an array of proximal screws designed to target the best-quality bone. Multiplanar fixation acts as a scaffold, aiding in fracture reduction and realignment.

Polarus Locking Humeral Rod	Length	Distal Diameter
Locking Humeral Rod	177 mm	5 mm

Polarus Plus Humeral Rods	Length	Distal Diameter
Humeral Rod	200 mm	10 mm
Humeral Rod	220 mm	10 mm
Humeral Rod	240 mm	10 mm
Humeral Rod	260 mm	10 mm
Humeral Rod	280 mm	10 mm

**Note:** Proximal diameter of all nails is 11 mm.



**Radiolucent Targeting Guides**  
Designed to provide visibility to confirm precise rod and screw placement

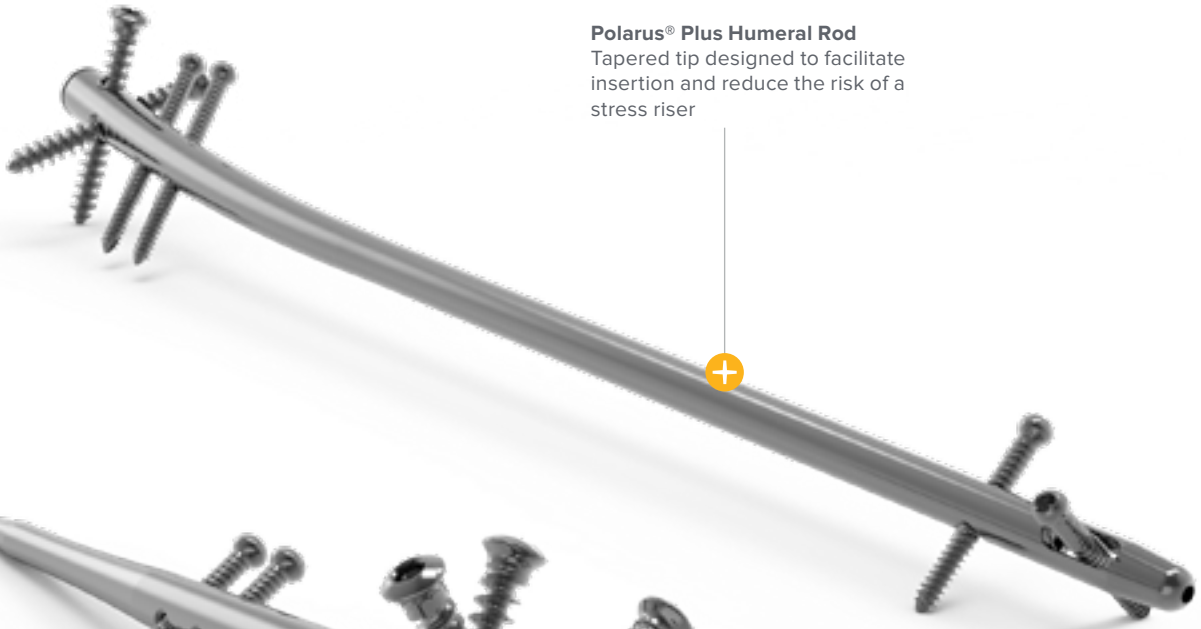

**Polarus® Plus Humeral Rod**  
Tapered tip designed to facilitate insertion and reduce the risk of a stress riser



**Polarus Locking Humeral Rod**  
Multiple divergent screw trajectories designed to maximize construct stability



Polarus Locking Humeral Rod



Polarus Plus Humeral Rods



**Medial Border Plate**

Designed to match patient's scapula curvatures to help restore original anatomy; the plate can be used in conjunction with the Lateral Border Plate

**Lateral Border Plate**

Designed to match the patient's scapular anatomy, resulting in a more secure reconstruction of severely displaced scapular body and glenoid neck fractures



**Acromion Plate**

Designed to closely match the patient's natural bone curvatures, which may help in the reconstruction of even severely displaced acromion fractures

**Glenoid Plate**

Solution for fractures of the posterior margin of the glenoid and displaced intra-articular glenoid fractures

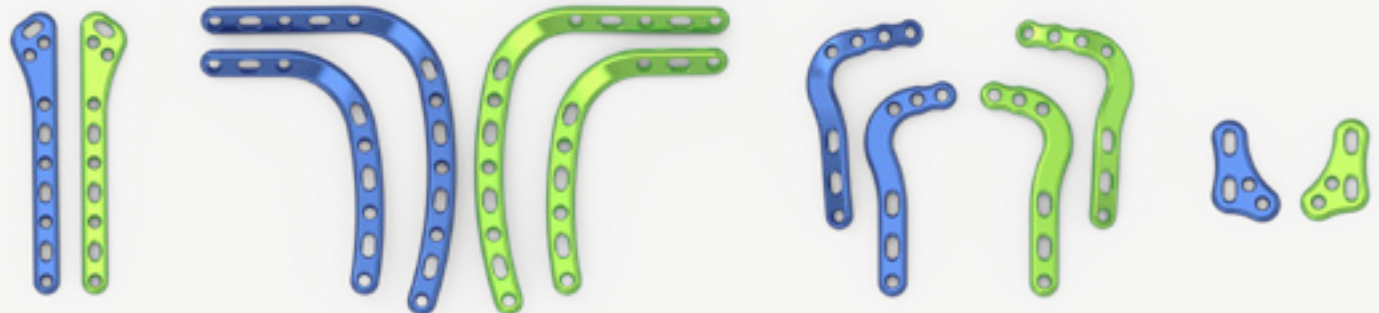

Lateral Border Plate

Medial Border Plate

Acromion Plate

Glenoid Plate

## Scapula Plating System

The Acumed Scapula Plating System offers anatomic-specific titanium plates designed to address challenging fractures of the scapula. Precontoured plates are intended to minimize the need for intraoperative plate bending to help save operating time and allow the surgeon to focus on restoring scapular anatomy. The tray design allows it to be placed in the Acumed Clavicle Plating System to expand surgical options.



Scapula Plates	Hole Count	Length	Width
Lateral Border Plate, Left, Right	10-hole	107 mm	18 mm
Medial Border Plate, Left, Right	9-hole	87 mm	64 mm
Medial Border Plate, Left, Right	13-hole	110 mm	88 mm
Acromion Plate, Left, Right	6-hole	75 mm	32 mm
Acromion Plate, Left, Right	7-hole	78 mm	45 mm
Glenoid Plate, Left, Right	4-hole	36 mm	24 mm

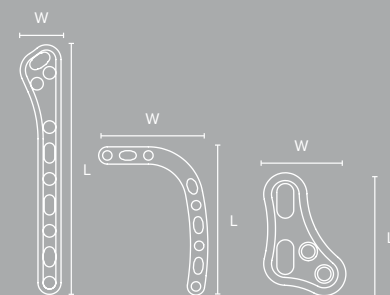

Launched in 2007, Acumed's Scapula Plating System introduced the first precontoured plates designed specifically for treating scapula fractures.

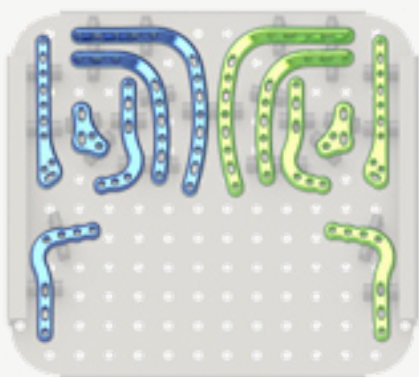

### Targeting Glenoid Fractures

Plate placement and screw fixation to osseous regions of superior scapular thickness may increase the construct's strength



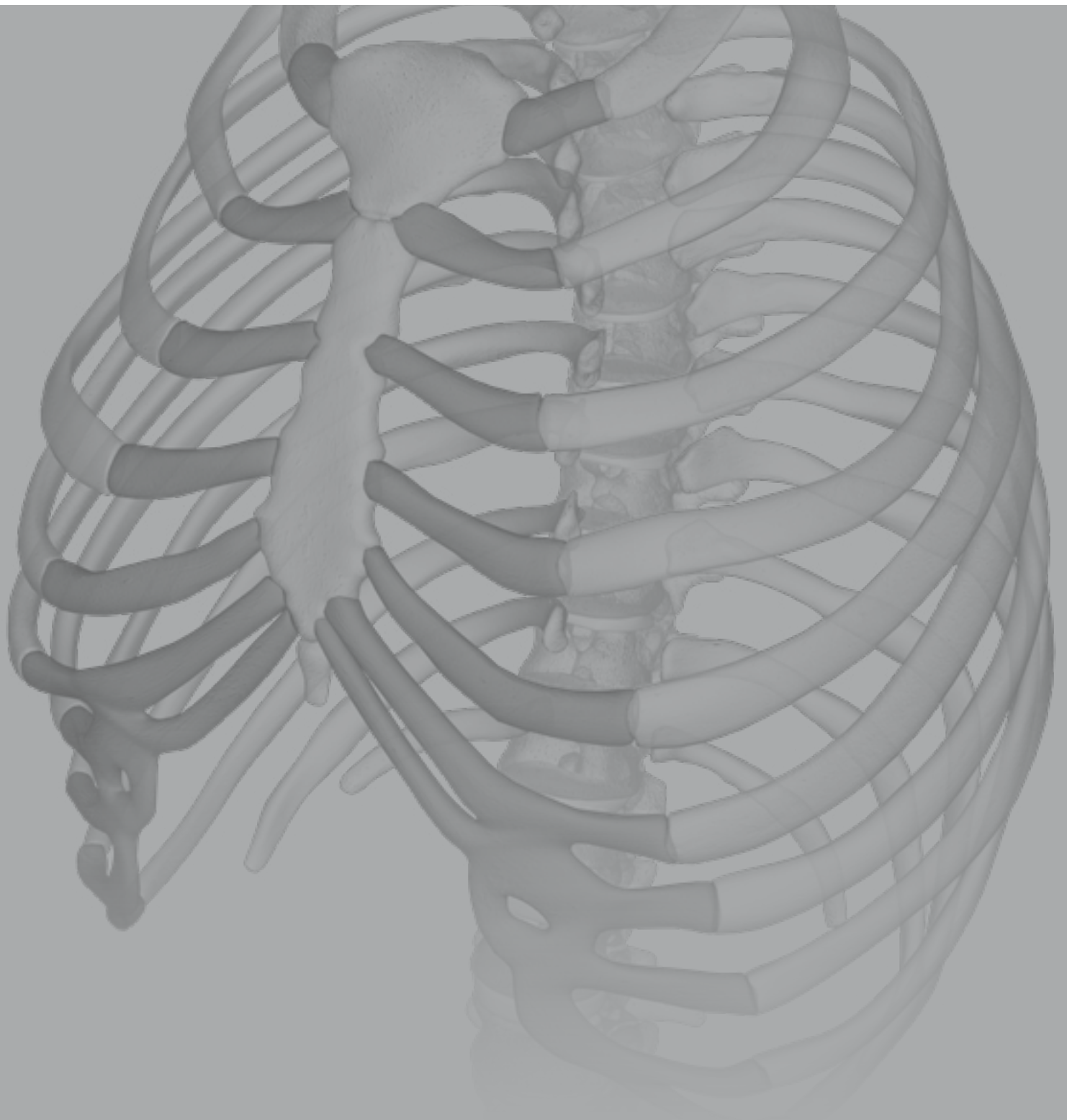

# Chest Wall Product Lineup

AcuTie® II .....52

BioBridge® Resorbable Chest Wall Stabilization Plate .....54

RibLoc® U Plus Chest Wall Plating System .....56

## AcuTie® II

The AcuTie II Sternum Closure System encompasses the simplicity of standard wire cerclage while providing increased compression, stability in multiple planes, lateral protection, and straightforward installation. It is intended for use in the stabilization and fixation of fractures of the anterior chest wall, including sternal fixation following sternotomy and sternal reconstructive surgical procedures.

AcuTie II Plate	Length	Width	Thickness
AcuTie II Plate	21 mm	20 mm	2.5 mm

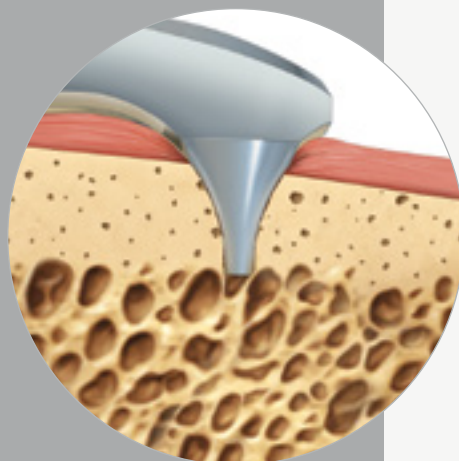
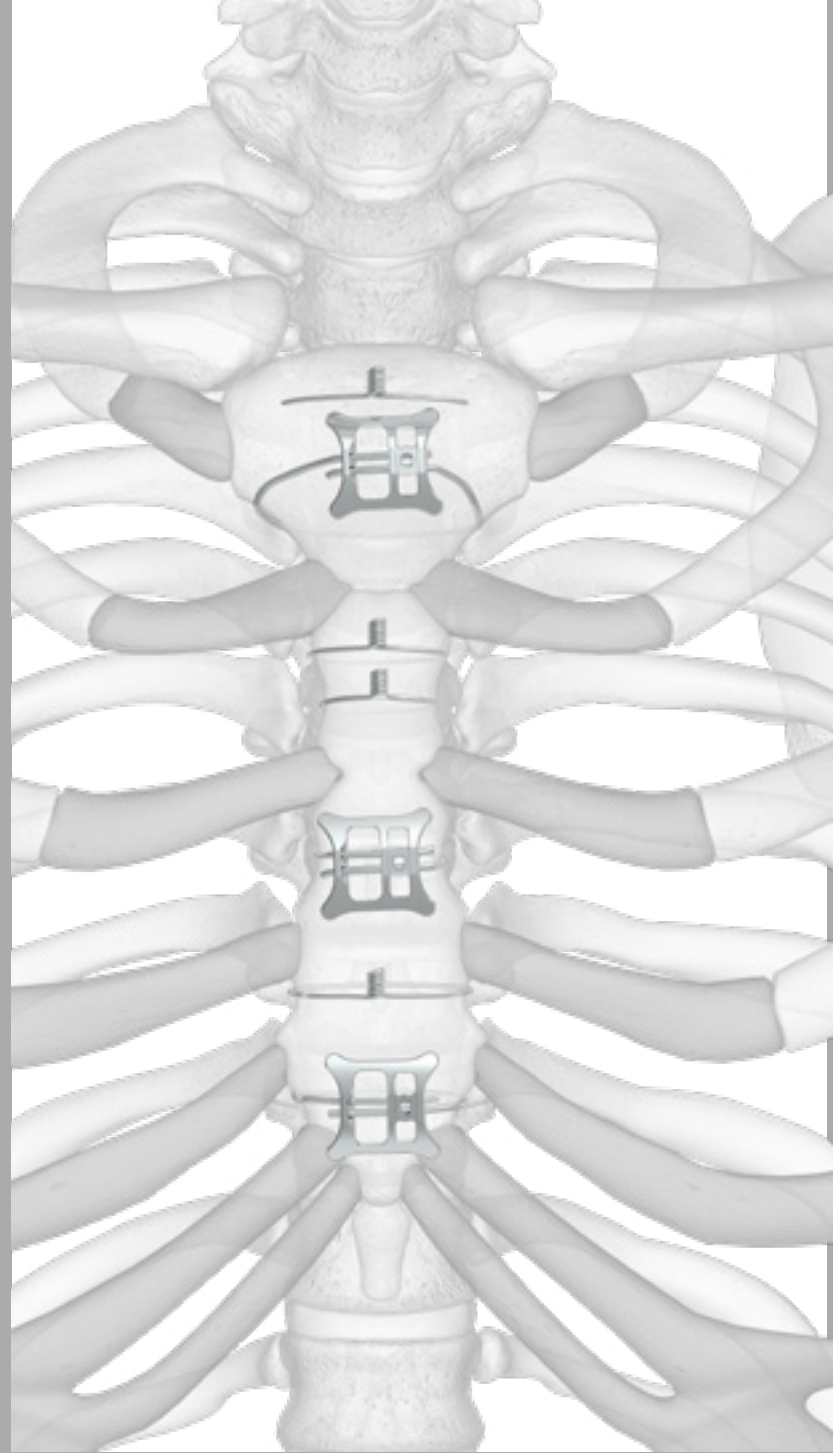
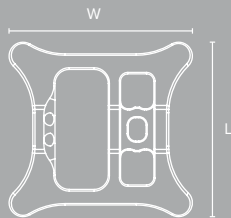

### Lateral Protection

Directional cleats penetrate through soft tissue and into the bone for stability, like a screw, while distributing the load and reducing stresses on the lateral edges of the sternum

Like barbs, they allow medial movement of the sternum halves during reduction and gripping during distraction

1. Data on file at Acumed.



**Crimp Feature**  
Crimp locks in compression and resists wire fatigue

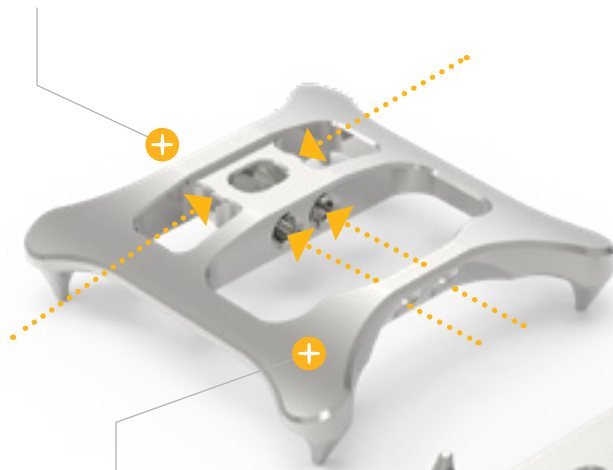

**Complete Stability**  
Directional cleats penetrate the cortex to create stability and resist motion in all three planes: lateral, rostral-caudal, and anterior-posterior

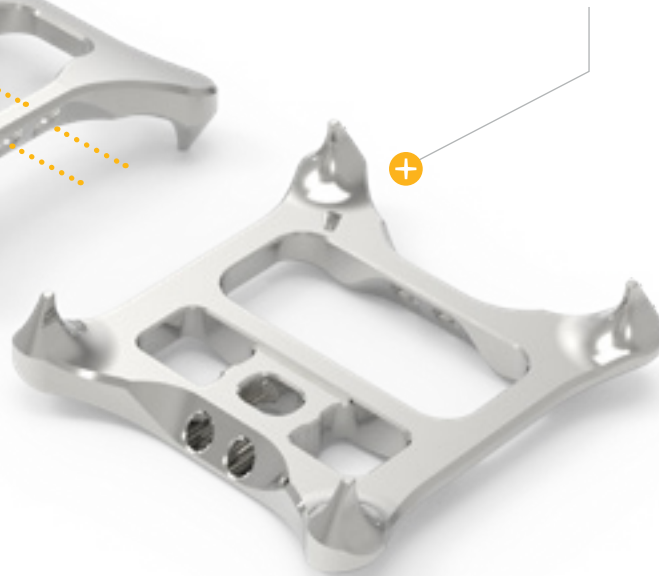

**Quick, Repeatable Installation**  
Plate installs in less than 90 seconds¹

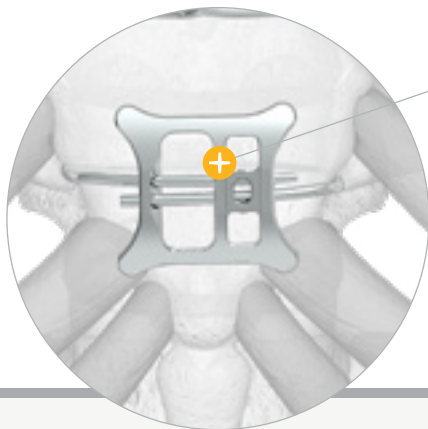

**Fast Re-Entry**  
Confident re-entry without specialized instrumentation



AcuTie® II Plate



Crimper



Tensioner

**Chest Wall Reconstruction**  
 Reconstruction technique<sup>2</sup> provides long-term chest wall stability through bone healing and/or soft-tissue scarring

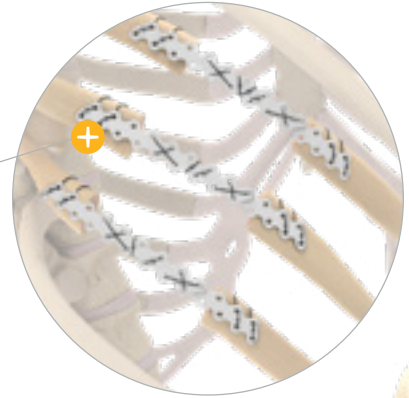

**Customizable Solution**  
 BioBridge® is flexible and can be stacked or trimmed for increased rigidity and/or length

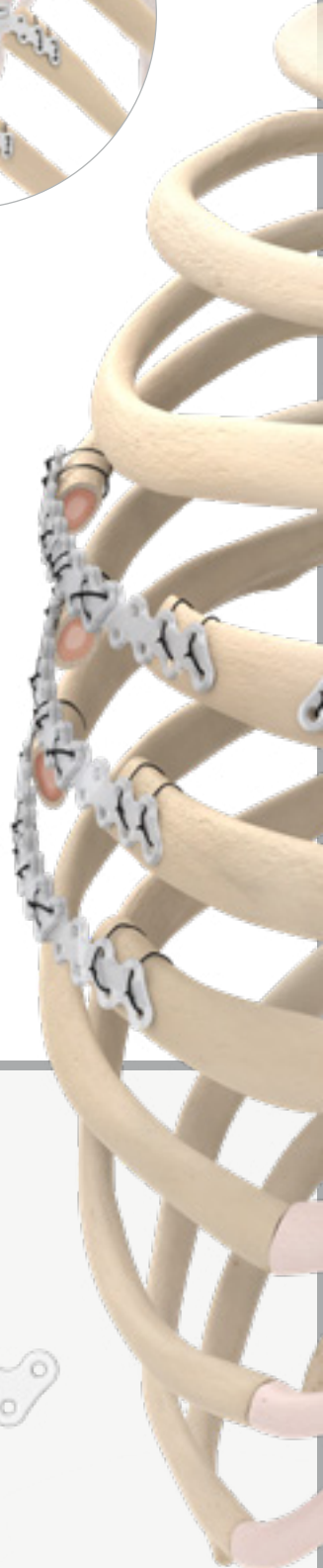

Side view

Doublet



Top view

Triplet





In 2008, Acumed was the first company to distribute a resorbable plate for rib fixation.

## BioBridge® Resorbable Chest Wall Stabilization Plate

BioBridge is a versatile, resorbable solution for chest wall stabilization. It is specifically designed to offer strength that exceeds typical chest wall loading and a resorption time that outlasts typical bone healing time.<sup>1</sup>



BioBridge Plate	Length	Width	Thickness
BioBridge Plate	110 mm	14 mm	1.8 mm

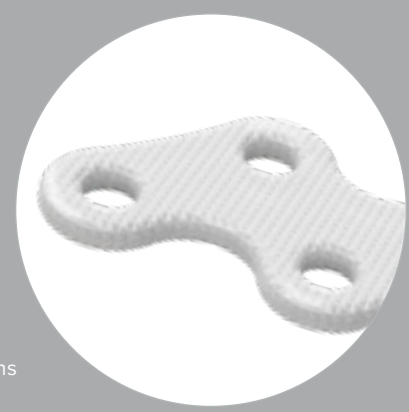

**Nonpermanent Chest Wall Stabilization**  
Fully resorbed within 18–24 months through hydrolysis<sup>1</sup>

1. Data on file at Acumed.  
2. BioBridge Resorbable Chest Wall Stabilization Plate Chest Wall Reconstruction Surgical Technique (RRP7120).

**Most Comprehensive System**

The only rib plating system on the market that offers both U-plates and straight anterior plates in one system, RibLoc® U Plus also offers the shortest plate on the market, the 50 mm U-plate

**Custom Fit to the Rib**

Advanced plate design offers a compressible U-clip to fit to a broad range of rib thicknesses (6–14 mm)

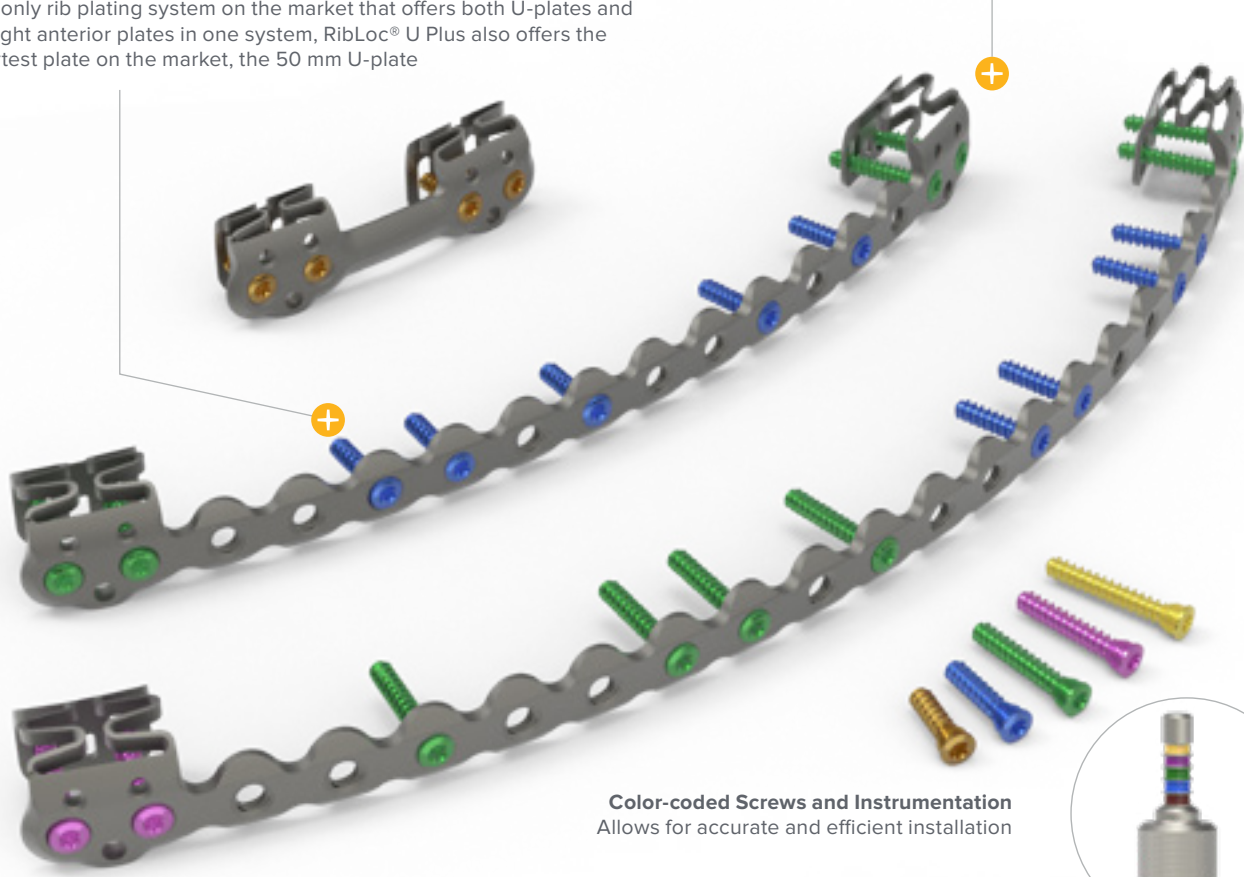





**Color-coded Screws and Instrumentation**  
Allows for accurate and efficient installation

**W&H Amadeo Control Unit\***  
The unit offers power for compressing the plate to the rib, drilling, and driving screws for fixation of subscapular, posterior, and anterolateral fractures through minimally invasive approaches.



U Plus Plates

Straight Plate

-  Gold – 14 mm
-  Fuchsia – 12 mm
-  Green – 10 mm
-  Blue – 8 mm
-  Brown – 6 mm



## RibLoc® U Plus Chest Wall Plating System

The RibLoc U Plus Chest Wall Plating System is intended to stabilize and provide fixation for fractures, fusions, and osteotomies of the ribs, and for reconstructions of the chest wall and sternum. First to market with plates designed for the rib, this comprehensive system includes multiple plate options for varying fracture locations and patterns.

RibLoc U Plus Plates	Length	Thickness
U Plus Plate	215 mm	1.6 mm
U Plus Plate	155 mm	1.6 mm
U Plus Plate	115 mm	1.6 mm
U Plus Plate	75 mm	1.6 mm
U Plus Plate	50 mm	1.6 mm
<hr/>		
Straight Plate	126 mm	1.6 mm

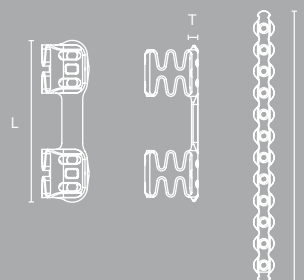

In 2006, Acumed was the first company to offer a plate specifically designed for rib fixation.

### U-plate Technology

Plates designed to sit on the superior aspect of the rib, avoiding the neurovascular bundle<sup>1</sup>

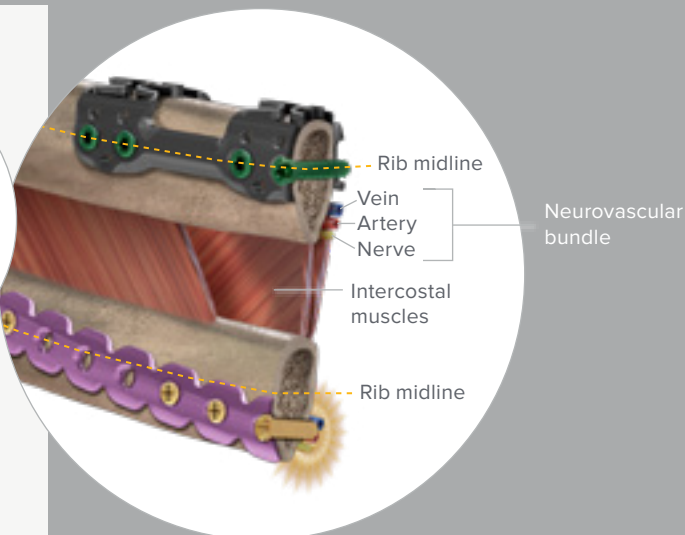
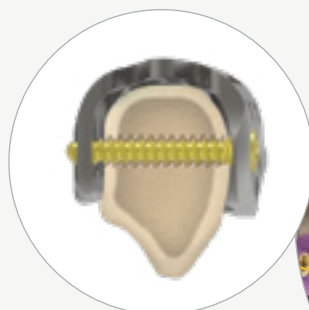

1. Data on file at Acumed.

\*Other power units may be available in different regions.



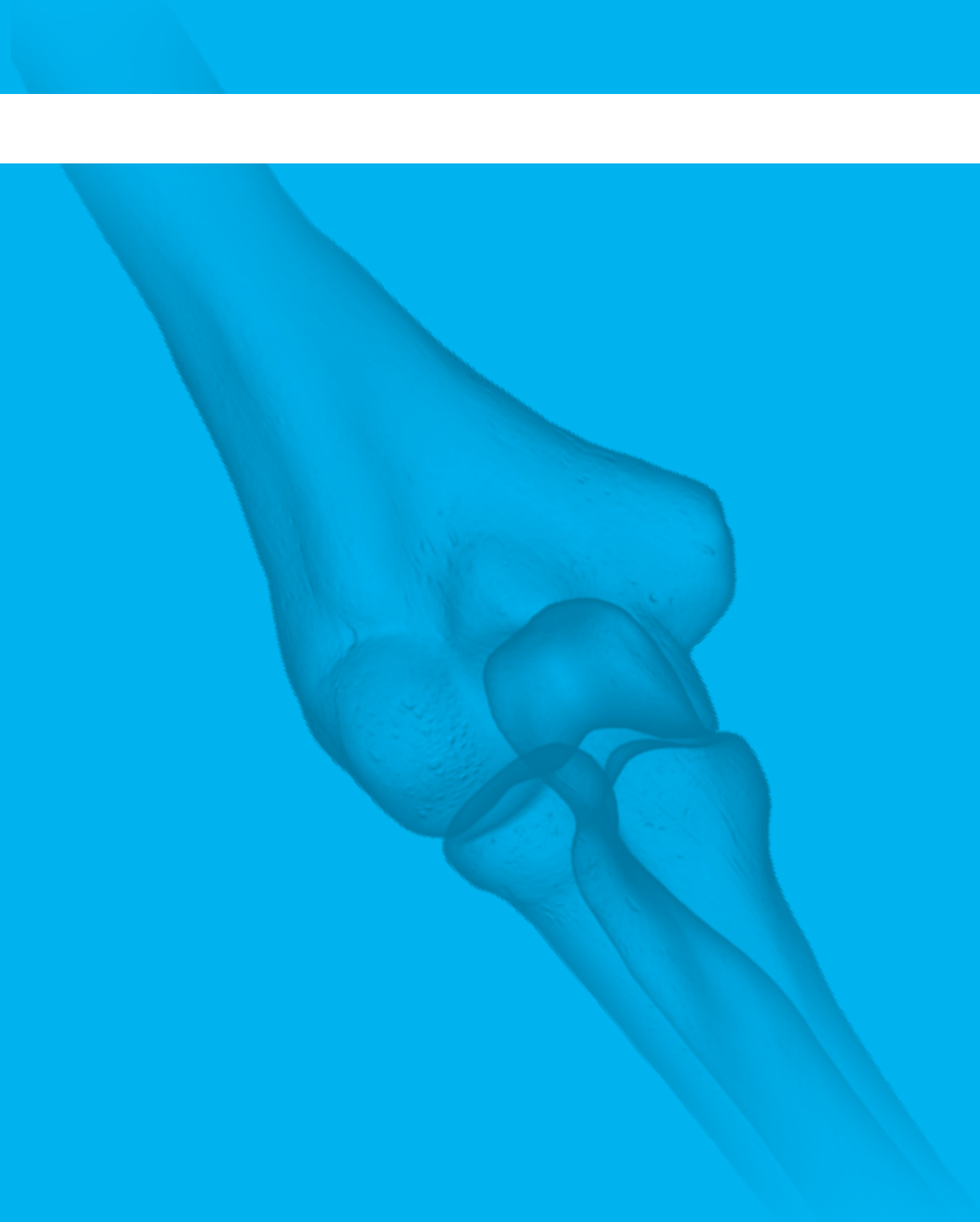

## Elbow Product Lineup

Anatomic Radial Head Solutions 2 .....	60
Anatomic Radial Head Solutions .....	62
Anatomic Radial Head System .....	64
Elbow Plating System .....	66
Congruent Elbow Plating System .....	68
Radial Head Plating System .....	70

## Anatomic Radial Head Solutions 2

The Acumed Anatomic Radial Head Solutions 2 expands the comprehensiveness of the Anatomic Radial Head Solutions System by adding new stem and head diameters, bringing the head and stem combinations to 924. The Anatomic Radial Head Solutions 2 adds an 18 mm head option, 11 and 12 mm standard stems, and 7, 9, and 11 mm long stems. The set may include the Acutrak 2<sup>®</sup> Mini and Micro instruments and the Radial Head Plating System at the base of the tray to provide multiple solutions in one set.

### Anatomic Radial Head Implant Diameters

18 mm, 20 mm, 22 mm, 24 mm, 26 mm, 28 mm

Standard Stem Implants*	Diameter	Length
Standard Stem	6 mm	25 mm
Standard Stem	7 mm	25 mm
Standard Stem	8 mm	25 mm
Standard Stem	9 mm	25 mm
Standard Stem	10 mm	25 mm
Standard Stem	11 mm	25 mm
Standard Stem	12 mm	25 mm
Collar Heights	+0 mm, +2 mm, +4 mm, +6 mm, +8 mm	

\*Optional: Partial Grit Blast

Long Stem Implants	Diameter	Length
Long Stem	6 mm	50 mm
Long Stem	7 mm	52.5 mm
Long Stem	8 mm	55 mm
Long Stem	9 mm	57.5 mm
Long Stem	10 mm	60 mm
Long Stem	11 mm	62.5 mm
Long Stem	12 mm	65 mm

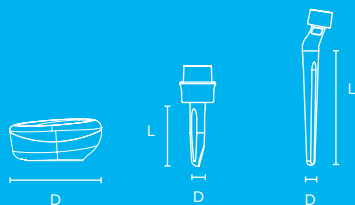

1. Sahu D, Holmes DM, Fitzsimmons JS, et al. Influence of radial head prosthesis design on radiocapitellar joint contact mechanics. *J Shoulder Elbow Surg.* 2014;23(4):456-462.



PEEK Suture Anchor System



**Insertion Depth Line**  
Laser mark on stem indicates proper insertion depth

**Alignment Marks**  
Hashed laser marks indicate proper alignment with Lister's tubercle or the lateral aspect of the radius when the forearm is in the neutral position

2. Bachman DR, Thaveepunsan S, Park S, Fitzsimmons JS, An KN, O'Driscoll SW. The effect of prosthetic radial head geometry on the distribution and magnitude of radiocapitellar joint contact pressures. *J Hand Surg Am.* 2015;40(2):281-288.

**Radial Head Dish Depth**

The dish depth increases with head diameter, which is designed to help improve radiocapitellar wear characteristics over nonanatomic heads and the first-generation Acumed Anatomic Radial Head<sup>1,2</sup>

**Medial Surface**

The implant's medial surface is contoured to better replicate the lateral trochlear ridge facet, which may help avoid cartilage erosion<sup>2</sup>

**Medial Side Contouring**

Contouring of the medial side of the head has been further refined to track against the radial notch of the ulna<sup>2</sup>



**Grit-Blasted Stems**

Both fully and partially grit-blasted stems are now offered, and are designed to promote bony ongrowth



**Complete Range of Long Stems**

With lengths from 50–65 mm and diameters from 6–12 mm, in 1 mm increments, long stems are included in the system for distal fractures and revision following surgeries



Radial Head Implants



Standard and Partial Grit Blast Stem Implants



Long Stem Implants



**Long Stems Added**

Long stems were added for fractures that extend distally past the radial neck and for revision following failed radial head arthroplasty

**Alignment Marks**

Hashed laser marks indicate proper alignment with Lister's tubercle or the lateral aspect of the radius when the forearm is in the neutral position

**Insertion Depth Line**

Laser mark on stem indicates proper insertion depth

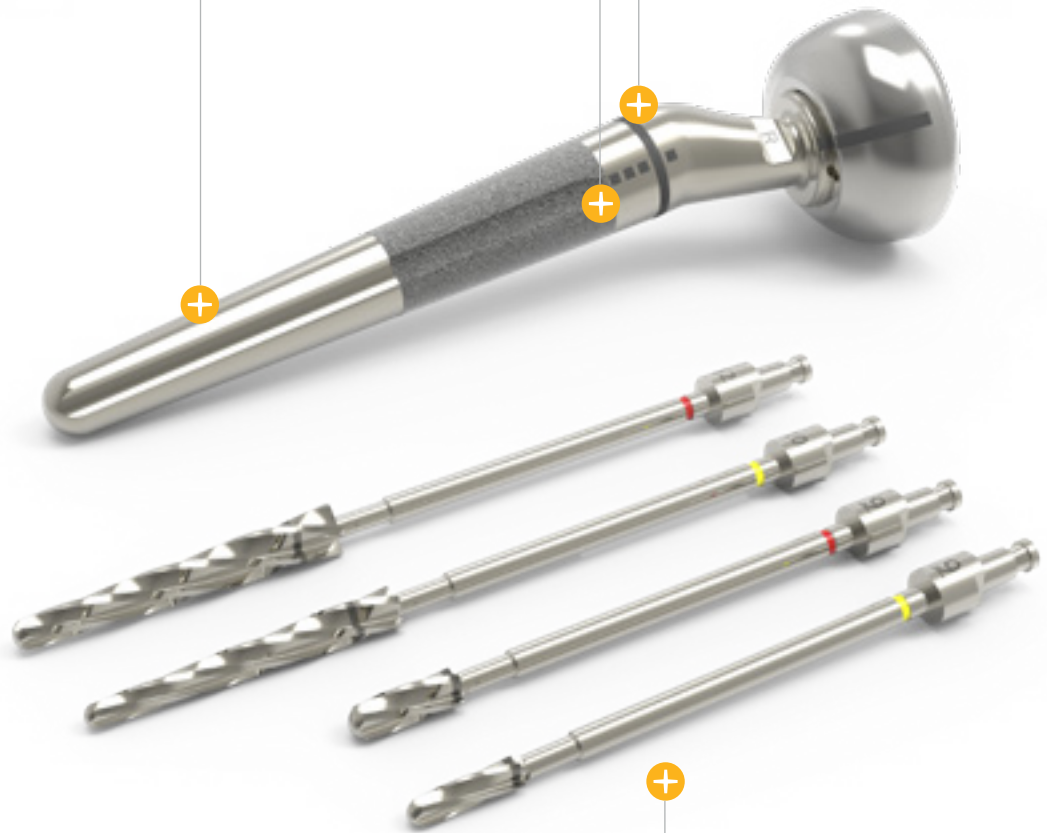

**Reamers Replace Broaches for Canal Preparation**

Reamers may allow for a larger stem diameter than broaches and may decrease risk of fracture compared to broaches<sup>1</sup>



Radial Head Implants



Standard Stem Implants



Long Stem Implants



## Anatomic Radial Head Solutions

The Acumed Anatomic Radial Head Solutions expands the comprehensiveness of the Anatomic Radial Head System by adding long stems, bringing the head and stem combinations to 290. The Anatomic Radial Head Solutions set also replaced broaches with reamers for canal preparation. The set may include the Acutrak 2® Mini and Micro instruments and the Radial Head Plating System at the base of the tray to provide multiple solutions in one set.

### Anatomic Radial Head Implant Diameters

20 mm, 22 mm, 24 mm, 26 mm, 28 mm

Standard Stem Implants	Diameter	Length
Standard Stem	6 mm	25 mm
Standard Stem	7 mm	25 mm
Standard Stem	8 mm	25 mm
Standard Stem	9 mm	25 mm
Standard Stem	10 mm	25 mm
Collar Heights	+0 mm, +2 mm, +4 mm, +6 mm, +8 mm	

Long Stem Implants	Diameter	Length
Long Stem	6 mm	50 mm
Long Stem	8 mm	55 mm
Long Stem	10 mm	60 mm
Long Stem	12 mm	65 mm

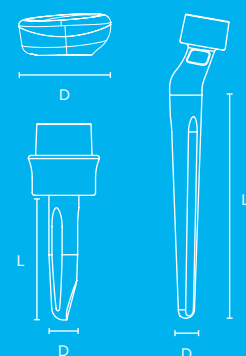

### Radius Retractor Instrument

The radius retractor is intended to facilitate reaming, trialing, and insertion of the anatomic radial head

### Removal Instrumentation

An ARH Removal Tool Shaft in combination with the Cross Bar is available for stem removal if needed

1. Shukla DR, Shao D, Fitzsimmons JS, Thoreson AR, An KN, O'Driscoll SW. Canal preparation for prosthetic radial head replacement: rasping versus reaming. *J Shoulder Elbow Surg.* 2013;22(11):1474-1479.

## Anatomic Radial Head System

The Acumed Anatomic Radial Head System includes the first anatomically shaped radial head prosthesis introduced to the orthopaedic industry. The system offers 250 standard head and stem combinations, offering multiple options for varying patient anatomies.

### Anatomic Radial Head Implant Diameters

20 mm, 22 mm, 24 mm, 26 mm, 28 mm

Standard Stem Implants	Diameter	Length
Standard Stem	6 mm	25 mm
Standard Stem	7 mm	25 mm
Standard Stem	8 mm	25 mm
Standard Stem	9 mm	25 mm
Standard Stem	10 mm	25 mm
Collar Heights	+0 mm, +2 mm, +4 mm, +6 mm, +8 mm	

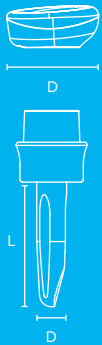

#### Color-coded for Identification

Color-coded broaches correspond with the implant trials to streamline the surgical procedure



The first anatomically shaped radial head implant on the market



1. Sahu D, Holmes D, Fitzsimmons J, et al. Influence of radial head prosthesis design on radiocapitellar joint contact mechanics. *J Shoulder Elbow Surg.* 2014;23(4):456-462.
2. El Sallakh S. Radial head replacement for radial head fractures. *J Orthop Trauma.* 2013;27(6):137-140.

**Anatomic Radial Head Prosthesis**

The anatomically shaped radial head is designed to mimic the radiocapitellar joint contact of a native radial head, which may help avoid cartilage erosion and capitellum wear over time as compared to nonanatomic prostheses<sup>1,2</sup>

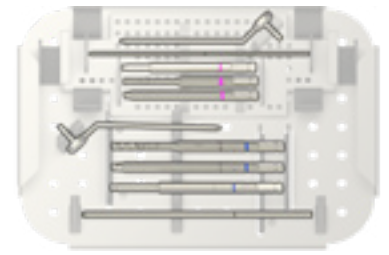

**Supplemental System**

The Acutrak 2® Mini and Micro Instruments may be included in the base of the tray, as well as the Radial Head Plating System, to expand the surgical options

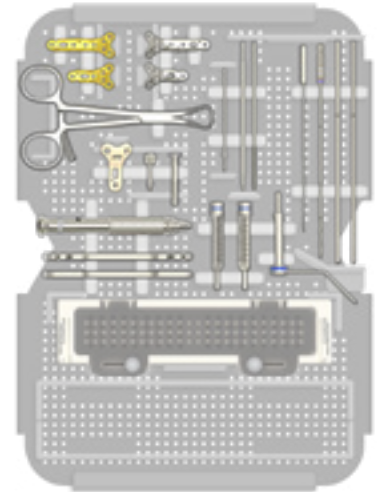

**Grit-Blasted Stems**

Grit-blasted stems are intended to promote bony ongrowth

20 mm, 22 mm, 24 mm, 26 mm, 28 mm Diameters

+0 mm, +2 mm, +4 mm, +6 mm, +8 mm Collar Heights  
6–10 mm Diameters



Radial Head Implants

Standard Stem Implants

**Olecranon Plate**

The olecranon plates are designed to provide an anatomic fit to the lateral bow of the ulnar shaft

Each olecranon plate features a 5° lateral tilt<sup>1</sup> to properly conform to the natural shape of the proximal ulna



**Coronoid Plate**

An offset screw hole is designed to help capture fractures of the sublime tubercle



**Posterolateral Plate**

The cluster of distal screws, angled distally and divergent from one another, is designed to allow the plate to sit proximally to avoid potential impingement on the olecranon and to capture fracture fragments



**Parallel Construct**

The Lateral Column Plates (above left) are engineered to allow the longer screws in the articular fragments to interdigitate with the screws from the Medial Column Plates (above right), creating a parallel construct to address complex fractures of the distal humerus

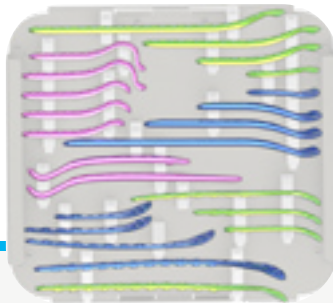
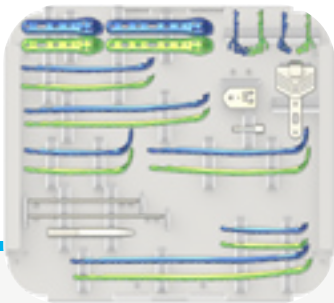

Distal Humerus Plates

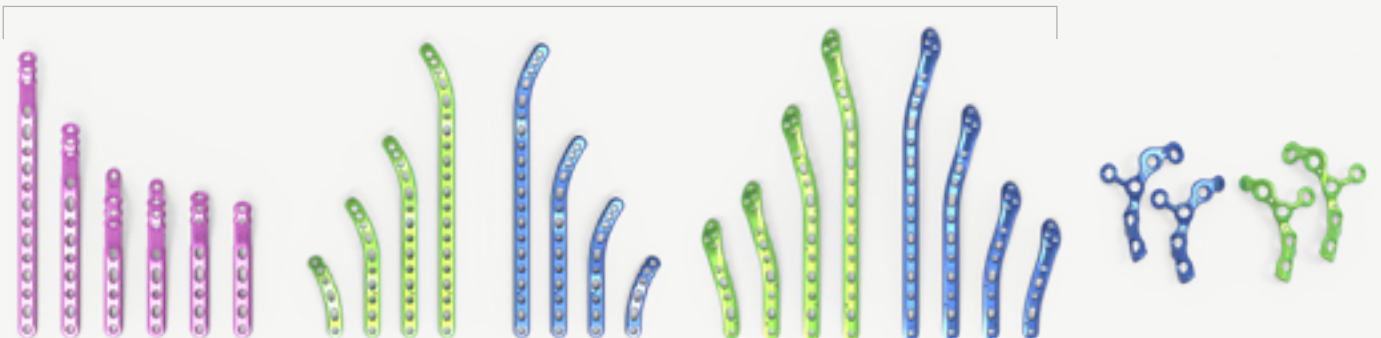

Locking Medial Column Plate

Locking Lateral Column Plate

Posterolateral Distal Humerus Plate

Coronoid Plate



## Elbow Plating System

The Acumed Elbow Plating System offers multiple fixation options for fractures of the distal humerus, olecranon, and coronoid. Enhancements to the previous system include precontoured Posterolateral Plates, left- and right-specific Olecranon Plates, and Hexalobe Screws. The system was designed in conjunction with Shawn O'Driscoll, MD, PhD.

Distal Humerus Plates	Hole Count	Length
Locking Medial Column Plate	7-hole	84 mm
Locking Medial Column Plate	8-hole	88 mm
Locking Medial Column Plate, Short	9-hole	95 mm
Locking Medial Column Plate, Long	9-hole	96 mm
Locking Medial Column Plate	12-hole	130 mm
Locking Medial Column Plate	16-hole	175 mm
Locking Lateral Column Plate, Left & Right	6-hole	58 mm
Locking Lateral Column Plate, Left & Right	10-hole	100 mm
Locking Lateral Column Plate, Left & Right	14-hole	142 mm
Locking Lateral Column Plate, Left & Right	20-hole	206 mm
Posterolateral Distal Humerus Plate, Left & Right	5-hole	78 mm
Posterolateral Distal Humerus Plate, Left & Right	7-hole	103 mm
Posterolateral Distal Humerus Plate, Left & Right	11-hole	152 mm
Posterolateral Distal Humerus Plate, Left & Right	15-hole	203 mm

Coronoid Plates	Hole Count	Length
Small Plate, Left & Right	5	22 mm
Standard Plate, Left & Right	6	24 mm

Olecranon Plates	Hole Count	Length
Narrow Plate, Left & Right	5-hole	85 mm
Standard Plate, Left & Right	3-hole	65 mm
Standard Plate, Left & Right	5-hole	90 mm
Standard Plate, Left & Right	7-hole	110 mm
Standard Plate, Left & Right	11-hole	150 mm
Standard Plate, Left & Right	15-hole	190 mm
Extended Plate, Left & Right	5-hole	90 mm
Extended Plate, Left & Right	9-hole	130 mm

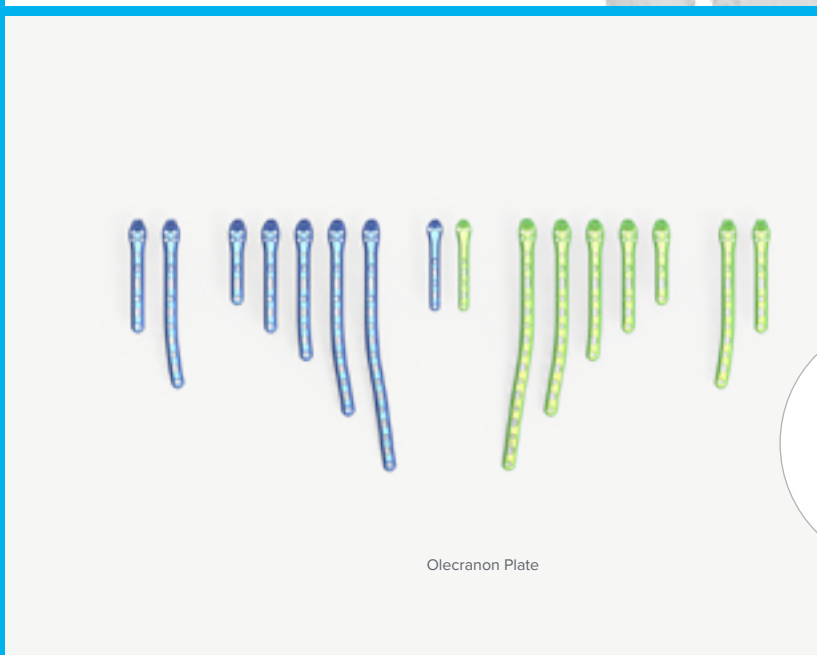

Olecranon Plate

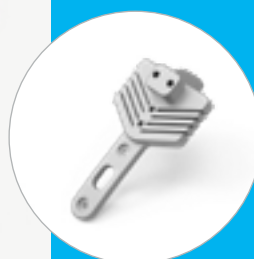

**Olecranon Osteotomy Cutting Jig**  
 Designed to create reproducible chevron osteotomies and allows for predrilling of proximal and distal screw holes

1. Rouleau D, Faber K, Athwal G. The proximal ulna dorsal angulation: a radiographic study. *J Shoulder Elbow Surg.* 2010;19(1):26-30.





# Congruent Elbow Plating System

Designed in conjunction with Shawn O’Driscoll, MD, PhD, the Acumed Congruent Elbow Plating System is designed to address fractures of the distal humerus, olecranon, and coronoid.



The first system on the market to offer parallel distal humerus plates

Olecranon Plates	Hole Count	Length
Locking Plate, Standard	9-hole	86 mm
Locking Plate, Standard	11-hole	106 mm
Locking Plate, Standard	13-hole	129 mm
Locking Plate, Standard, Left & Right	17-hole	173 mm
Extended Plate	13-hole	109 mm

Distal Humerus Plates	Hole Count	Length
Locking Medial Column Plate	7-hole	84 mm
Locking Medial Column Plate	8-hole	88 mm
Locking Medial Column Plate, Short	9-hole	95 mm
Locking Medial Column Plate, Long	9-hole	96 mm
Locking Medial Column Plate	12-hole	130 mm
Locking Medial Column Plate	16-hole	175 mm

Locking Lateral Column Plate, Left & Right	6-hole	58 mm
Locking Lateral Column Plate, Left & Right	10-hole	100 mm
Locking Lateral Column Plate, Left & Right	14-hole	142 mm
Locking Lateral Column Plate, Left & Right	20-hole	206 mm

Posterior Distal Humerus Plate, Standard	9-hole	95 mm
--	--------	-------

Coronoid Plates	Hole Count	Length
Standard Plate, Left & Right	2-hole	33 mm
Extended Plate, Left & Right	6-hole	68 mm



**Tap-Loc® Technology**  
The Acumed Tap-Loc technology is designed to be used with the Medial and Lateral Distal Humerus Plates to insert locking screws with up to 20 degrees of angulation



Olecranon Plate

**Coronoid Plate**

Prongs allow for provisional plate fixation on the anteromedial portion of the coronoid

**Olecranon Plate**

The cluster of screw holes in the articular region is designed to increase the stability and strength of the reconstruction

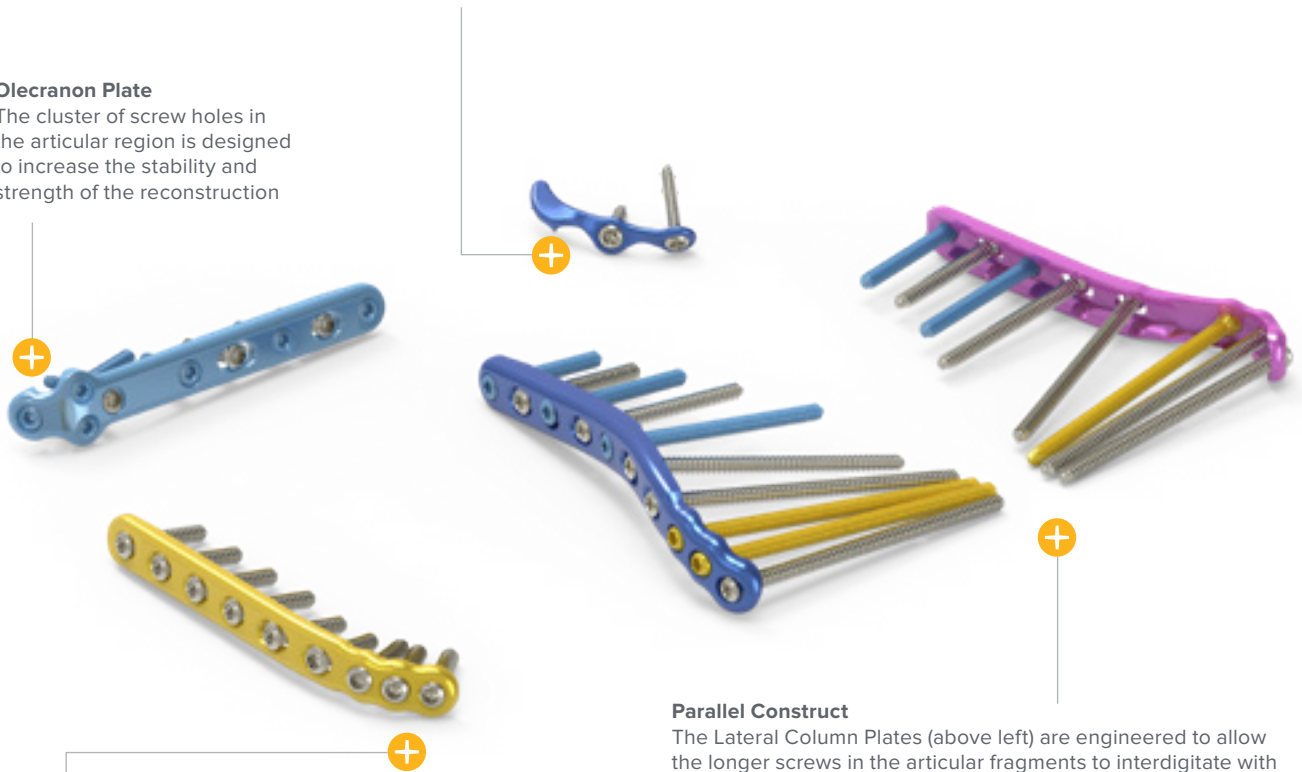

**Parallel Construct**

The Lateral Column Plates (above left) are engineered to allow the longer screws in the articular fragments to interdigitate with the screws from the Medial Column Plate (above right), creating a parallel construct to address complex fractures of the distal humerus

**Posterior Option**

A posterior plate offers an alternative to the lateral plate, and may be used in 90-90 plate placement for distal humerus fractures

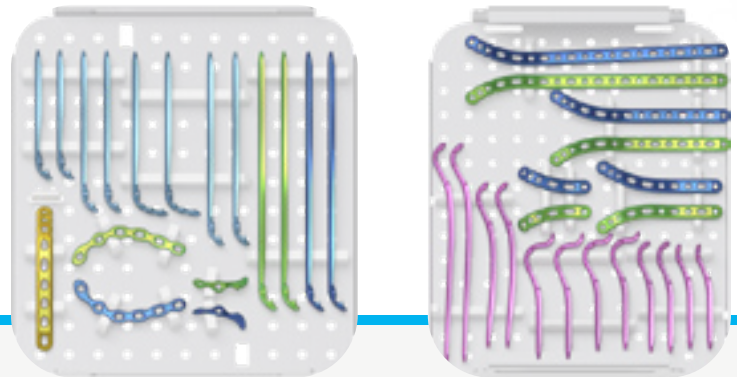

Distal Humerus Plates

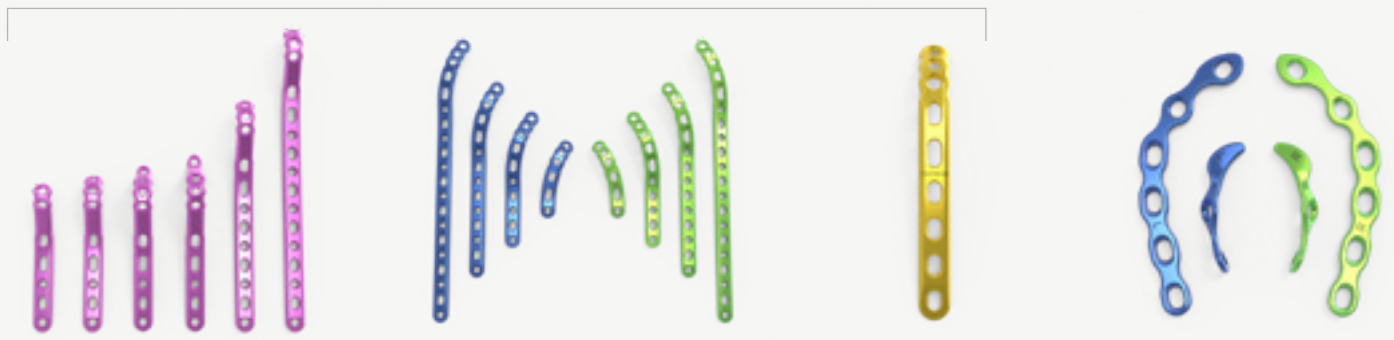

Locking Medial Column Plate

Locking Lateral Column Plate

Posterior Distal Humerus Plate

Coronoid Plate

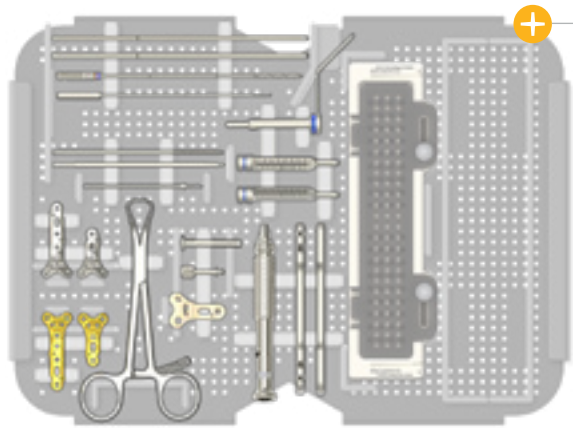

**Modular Tray**

This modular plate system may be included with both the Anatomic Radial Head System, and the Anatomic Radial Head Solutions System, or may be brought in as a standalone tray at the surgeon's request. The Acutrak 2" Mini and Micro Instruments are included at the base of the tray to expand the surgical options

**Strategic Screw Trajectory**

Converging and diverging locking screw angles are engineered to provide support and help capture fracture fragments

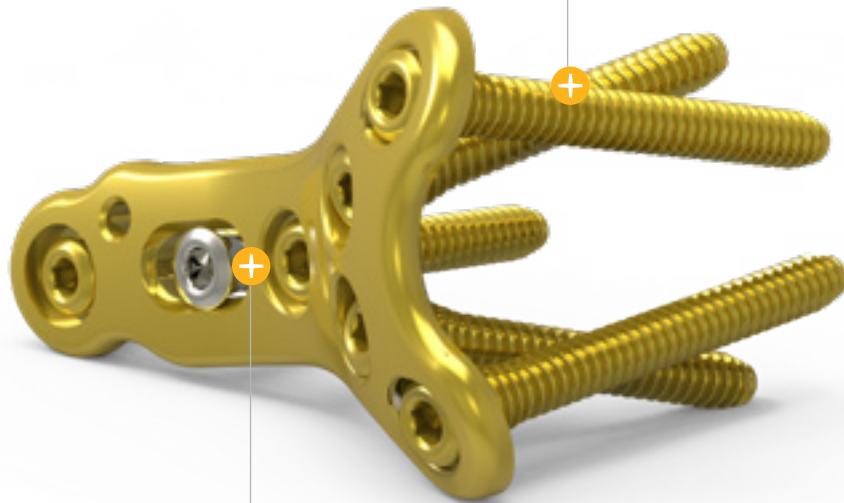

**Minimized Screw Prominence**

Locking and nonlocking 2.3 mm screws sit even with the plate's surface



Standard Curvature Plate



Small Curvature Plate

## Radial Head Plating System

The Acumed Radial Head Plating System is intended for fracture fixation when the radial head is salvageable. This modular plate system is included with all the Acumed Anatomic Radial Head replacement systems or may be brought in as a standalone tray at the surgeon's request.

Locking Radial Head (RH) Plates	Hole Count	Length
Locking RH Plate, Standard Curvature	3-hole	31 mm
Locking RH Plate, Standard Curvature	5-hole	46 mm
Locking RH Plate, Small Curvature	3-hole	31 mm
Locking RH Plate, Small Curvature	5-hole	46 mm

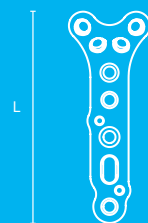

### Specialized Instrumentation

A radiolucent targeting guide is included to assist with threading the locking drill guide into the proximal locking holes

### Multiple Size Options

Two lengths and two head curvatures provide options for varying patient anatomies and fracture patterns







## Hand & Wrist Product Lineup

INnate™ Intramedullary Threaded Nail System .....	<b>74</b>
InFrame™ Intramedullary (IM) Threaded Micro Nail System .....	<b>76</b>
ArcPhix™ Angled Compression Screw .....	<b>78</b>
Hand Plating System .....	<b>80</b>
HPS Fusion Plates .....	<b>82</b>
Hand Fracture System .....	<b>84</b>
Small Bone External Fixation System .....	<b>86</b>
Ulna Nail 2 with Tip-Loc™ Technology .....	<b>88</b>
Anatomic Midshaft Forearm Plating System .....	<b>90</b>
Forearm Rod System .....	<b>92</b>
Acu-Loc® 2 Wrist Plating System .....	<b>94</b>
Acu-Loc® Wrist Plating System .....	<b>96</b>
Acu-Loc® Wrist Spanning Plate .....	<b>98</b>
ExtremiLock™ Wrist Plating System .....	<b>100</b>
Osteotomy System .....	<b>102</b>
Arc Wrist Tower .....	<b>104</b>
Total Wrist Fusion Plating System .....	<b>106</b>
Modular Hand System .....	<b>108</b>
Stableloc External Fixation System .....	<b>110</b>
Small Joint Reamer System .....	<b>112</b>

# INnate™ Intramedullary Threaded Nail System

The ExsoMed™ INnate Intramedullary Threaded Nail System features a dual diameter, stainless steel nail with a noncompressive design to achieve canal fill and stable fixation of metacarpal fractures. It delivers minimal soft-tissue damage and early to immediate range of motion. The robust length and diameter offering allows for precise anatomic reduction for all fracture types.

INnate Nail	Dual Diameters	Lengths
3.6 mm	Leading End: 3.2 mm Trailing End: 3.6 mm	25 - 55 mm (5 mm increments)
4.5 mm	Leading End: 4.0 mm Trailing End: 4.5 mm	35 - 55 mm (5 mm increments), 65 mm, 75 mm

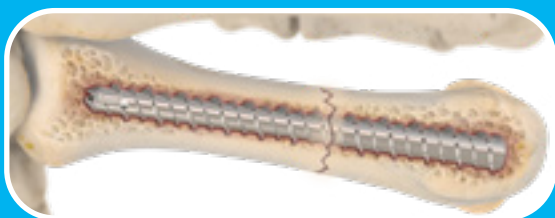
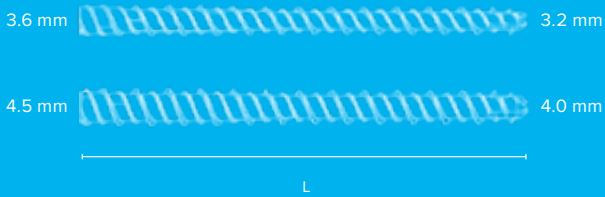

Dual diameter design facilitates passage through the metacarpal isthmus, providing optimal canal fill for stable fixation.



### INnate Disposable Instrument Kit

The system is provided sterile-packed. The implants are single use, while separate disposable instrument kits are available, specific to the implant diameter selected



Cannulated Driver



Cannulated Drill

Single Trocar Guidewire

Double Trocar Guidewire



Depth Gauge

**Fully Threaded**

Noncompressive, fully threaded design for circumferential cortical purchase in the intramedullary canal

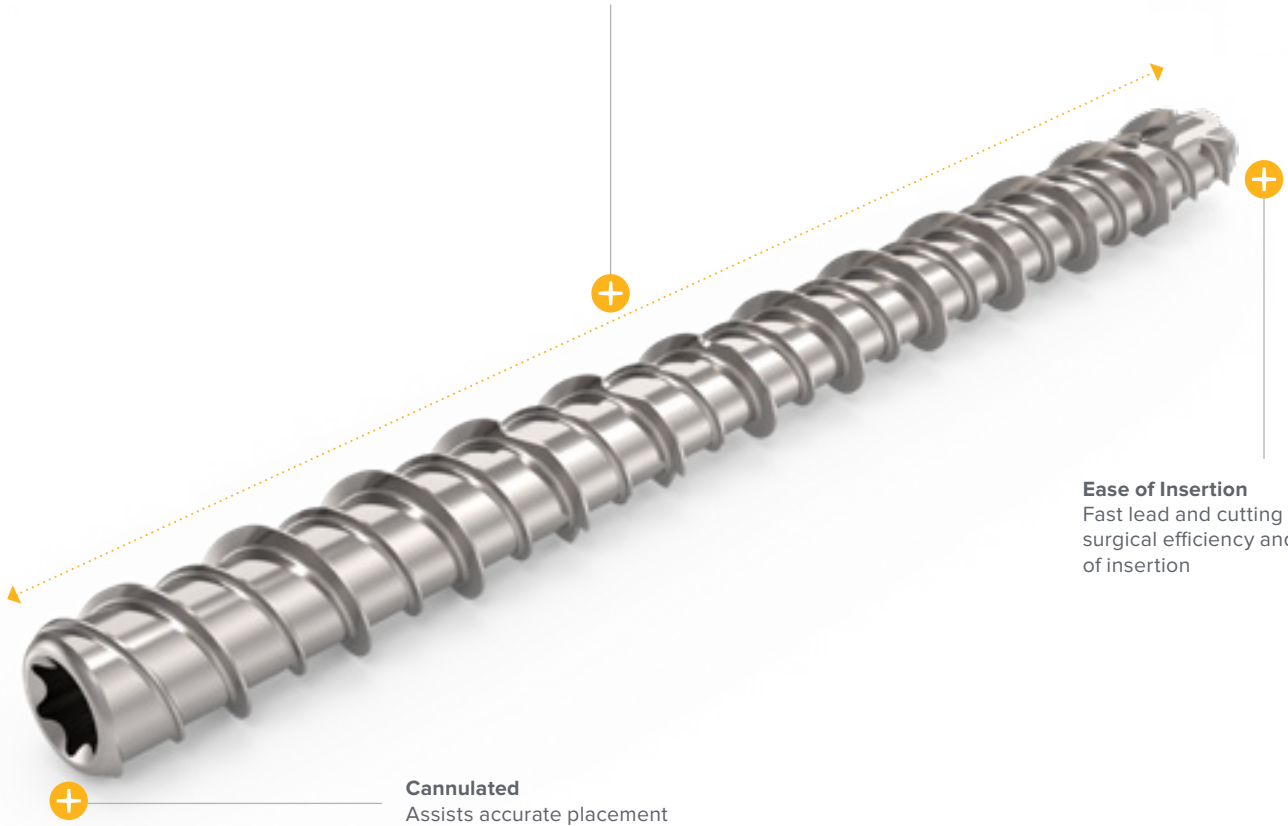

**Ease of Insertion**

Fast lead and cutting flutes enable surgical efficiency and ease of insertion

**Cannulated**

Assists accurate placement

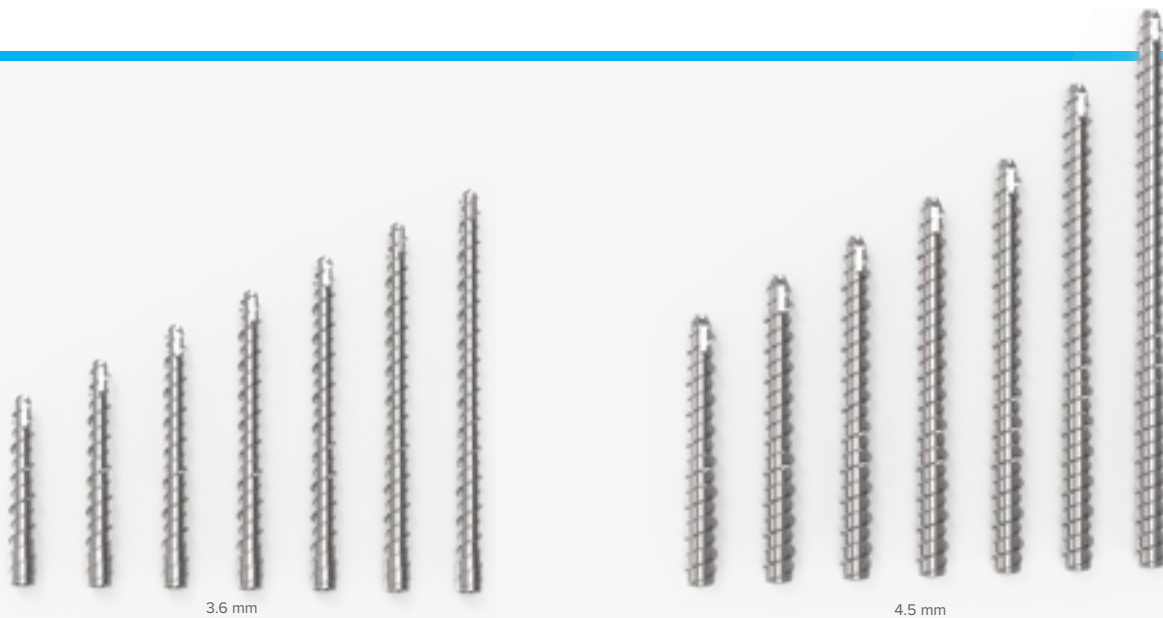

**Purpose-built**

Designed for the phalangeal intramedullary canal to facilitate immediate to early active mobilization for accelerated healing and faster return to daily activities

**Fully Threaded**

Assists circumferential cortical purchase in the intramedullary canal



**Cannulated**

Facilitates accurate placement

**Noncompressive**

Avoids shortening in oblique or comminuted fractures



2.0 mm Diameter

## InFrame™ Intramedullary (IM) Threaded Micro Nail System

The ExsoMed® InFrame Intramedullary Threaded Micro Nail System features a 2.0 mm diameter, stainless steel micro nail with a noncompressive design to achieve various implantation constructs for phalangeal fractures. It provides superior rotational and bending stability and intramedullary fixation. Delivery via an innovative dual diameter guidewire removes the need for a dedicated reamer and provides a more precise implant placement.

InFrame IM Micro Nail	Diameter	Lengths
InFrame Implant	2.0 mm	12–48 mm 2 mm Increments

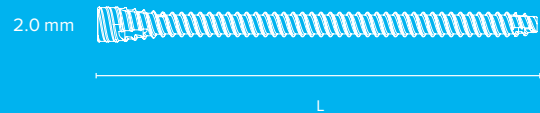

### InFrame Disposable Instrument Kit

The system is sterile-packed. The implants are single-use, while a separate disposable instrument kit is available for use with all implant sizes. The dual-diameter guide wire eliminates the need for a dedicated reamer, simplifying a more precise implant placement



Cannulated Hex Driver

2 – Dual Diameter Guide Wires, Single Trocar



Depth Gauge

### Multiple Construct Options

2.0 mm diameter, along with a wide array of lengths, offers multiple configuration options depending on fracture pattern, for greater rotational and bending stability, and cortical bone purchase



InFrame "X" Construct



InFrame "V" Construct



InFrame "Y" Construct



## ArcPhix™ Angled Compression Screw

The ExsoMed ArcPhix Angled Compression Screw is specially designed to achieve functional flexion and stable fixation of the distal interphalangeal (DIP) joint during bone fusions, offering improved finger dexterity and grip strength. Its 18° prebent design facilitates anatomic positioning of the fusion posture, providing surgeons with an automatic, angled fusion using a standard insertion technique.

ArcPhix Angled Compression Screw	Diameter	Length
ArcPhix Implant	3.0 mm	28 mm

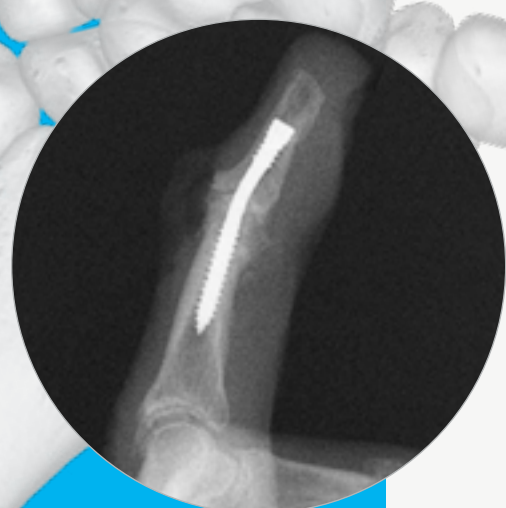

### Innovative Functional Solution

Angled fusion of the DIP joint allows functional flexion, where the distal end of the phalanges can maintain functionality, enabling improved finger dexterity and grip strength for everyday activities

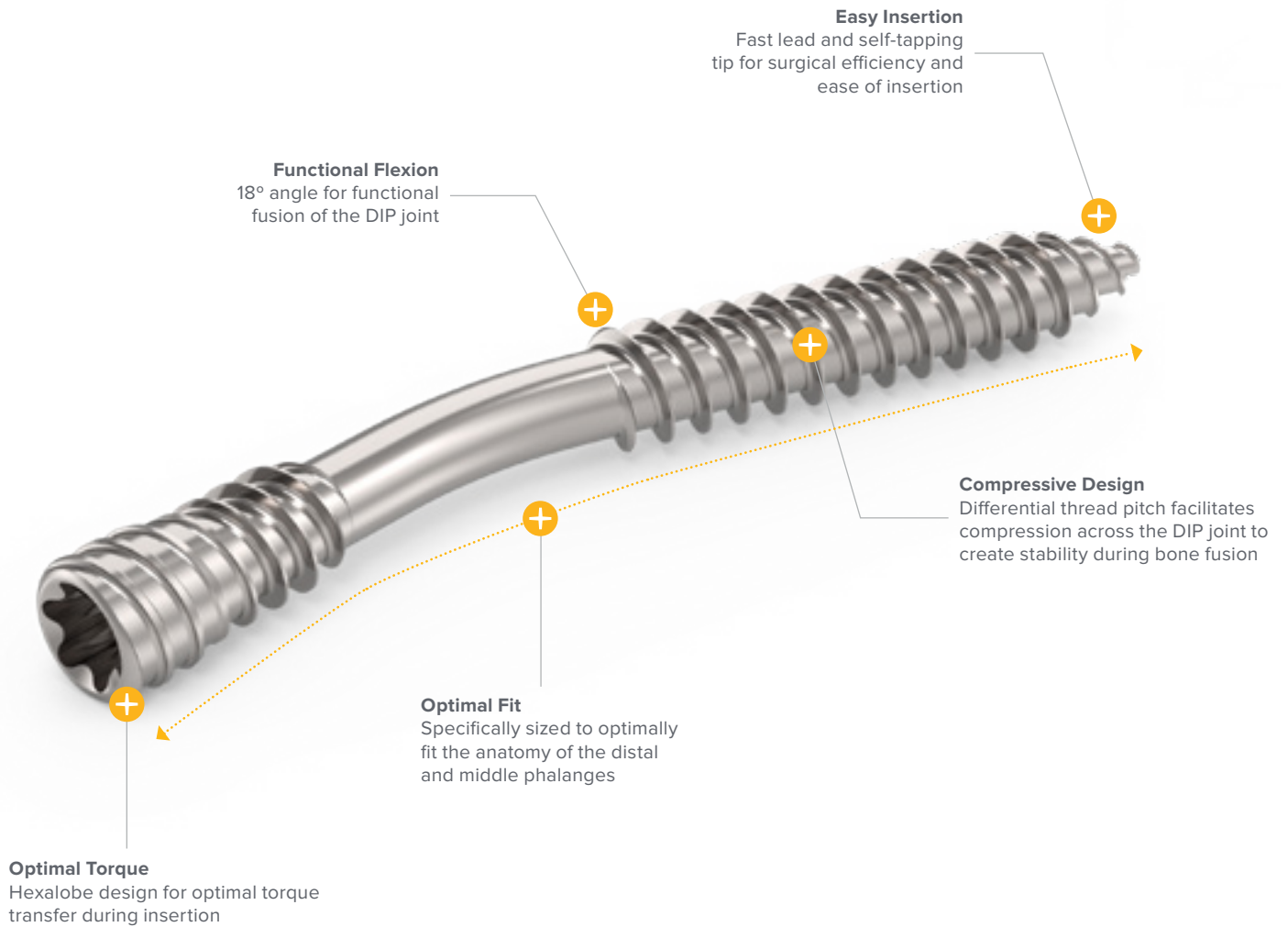

### ArcPhix System

The entire system is sterile-packed, single-use, and comes with the implant and instrument kit containing all the instrumentation necessary to place the implant

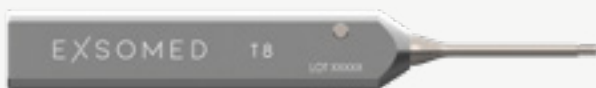

Cannulated Hexalobe Driver



Cannulated Reamer

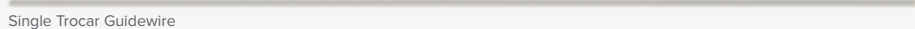

Single Trocar Guidewire

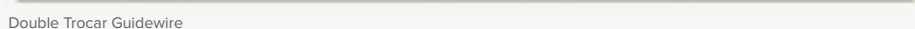

Double Trocar Guidewire



ArcPhix Implant

# Hand Plating System

The OsteoMed® Hand Plating System (HPS) features instrumentation and low-profile implants designed specifically for treating hand trauma. HPS features a full range of low-profile plates in four size modules: 1.2, 1.6, 2.0, and 2.4 mm. This plating system accepts up to four screw types: variable angle locking, nonlocking, lag, and cannulated. Also featured are hand fusion plates in two different sizes.

Standard Plates	Thickness
4-Hole Straight LCDCP*	2.0, 2.4 mm
6 Hole Straight Plate	1.2 mm
6-Hole Straight Plate, Locking	1.6, 2.0, 2.4 mm
6-Hole Straight Plate, Locking, TiA*	1.6, 2.0 mm
6-Hole Straight Plate, TiA*	2.4 mm
6-Hole Straight LCDCP*	2.0, 2.4 mm
8-Hole Straight LCDCP*	2.0, 2.4 mm
12-Hole Straight Plate	1.2 mm
12-Hole Straight Plate, Locking	1.6, 2.0, 2.4 mm
2 x 8 T Plate, Locking	2.0 mm
2 x 8 T Plate, Locking	2.4 mm
3 x 8 T Plate	1.2 mm
3 x 8 T Plate, Locking	1.6, 2.0, 2.4 mm
4 x 8 T Plate	1.2 mm
4 x 8 T Plate, Locking	1.6 mm
L Plate, Left and Right	1.2 mm
L Plate, Left and Right, Locking	1.6, 2.0, 2.4 mm
Y Plate	1.2 mm
Y Plate, Locking	1.6, 2.0, 2.4 mm

Specialty Plates	Thickness
Offset Grid Plate, Left and Right	1.2 mm
Offset Grid Plate, Locking, Left and Right	1.6, 2.0, 2.4 mm
Z Plate	2.0, 2.4 mm
Condylar Plate, Locking, Left and Right	1.6, 2.0, 2.4 mm
Subcondylar Plate, Locking	1.6, 2.0, 2.4 mm
Subcondylar Plate, Locking, TiA*	1.6, 2.0 mm
Subcondylar Plate, TiA*	2.4 mm
CMC (Carpometacarpal) Fusion Plate	2.0, 2.4 mm

Cannulated Screw	Length
2.0 mm Cannulated Lag Screw	6–16 mm - 1 mm Increments 18–36 mm - 2 mm Increments
2.4 mm Cannulated Lag Screw	6–16 mm - 1 mm Increments 18–36 mm - 2 mm Increments
2.0 mm Cannulated Headless Screw	10–14 mm - 1 mm Increments 16–36 mm - 2 mm Increments
2.4 mm Cannulated Headless Screw	10–14 mm - 1 mm Increments 16–36 mm - 2 mm Increments
3.0 mm Cannulated Headless Screw	10–14 mm - 1 mm Increments 16–36 mm - 2 mm Increments

\*Cannot be cut with HPS Plate Cutter

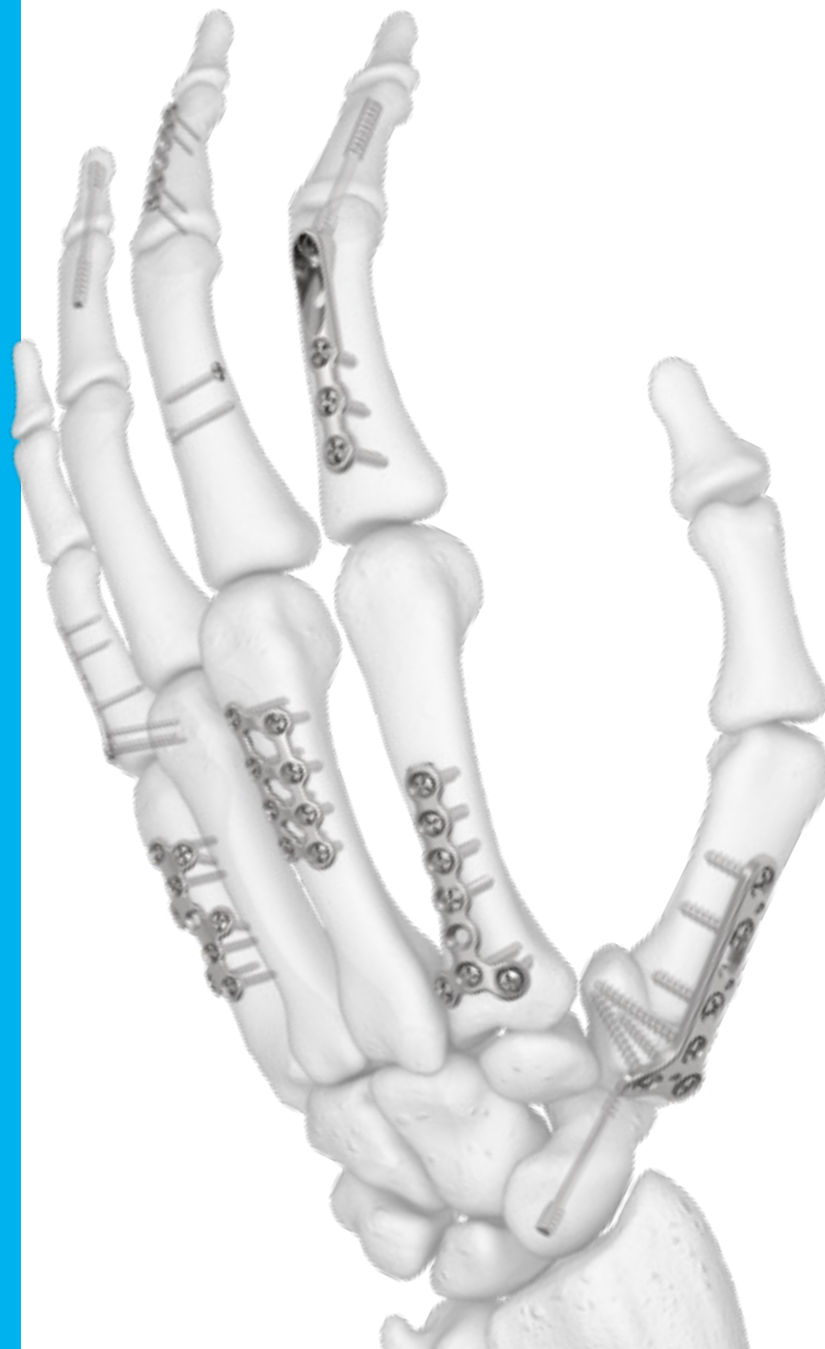

**TaperLock™ Technology**  
Designed for a low-profile screw and plate construct

**Plate Variety**

A full range of 68 plates with 4 screw diameters, including specialty implants for CMC, PIP, and MCP fusions



**Cut and Bent Fit**

Straight, T, and Y plates may be cut to length and bent to better fit patient anatomy

**Thumb CMC (Carpometacarpal) Fusion Plate**

Provides a singular option to fuse the CMC joint and is designed to fit the dorsal aspect of the thumb CMC articulation

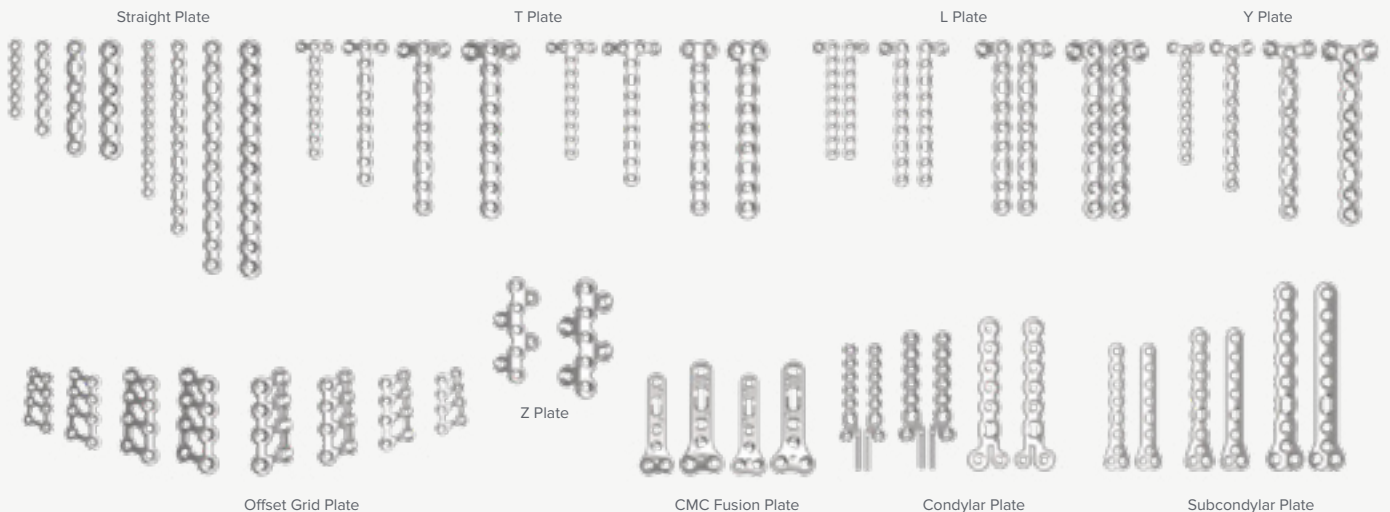

**Stable Fixation**  
Provides stable fixation of the PIP joint at a natural resting angle



**Variable-Angle Locking**

Compression

Cannulated

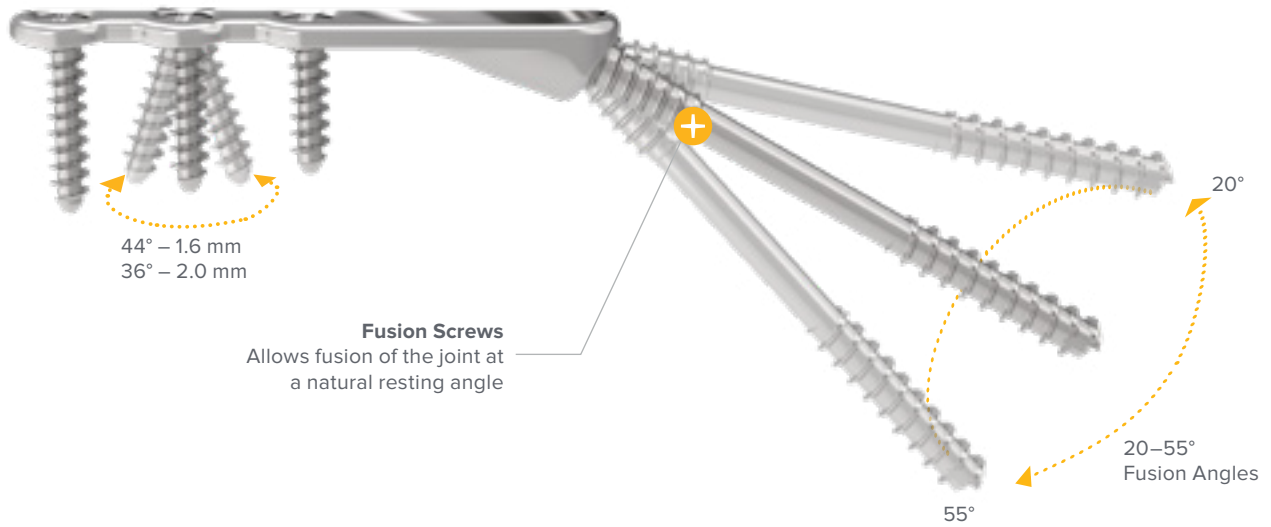
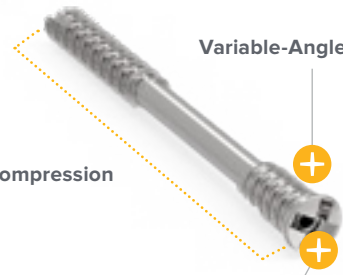

**Fusion Screws**  
Allows fusion of the joint at a natural resting angle

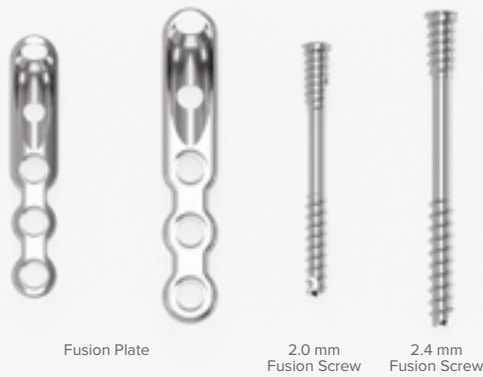

Fusion Plate

2.0 mm Fusion Screw

2.4 mm Fusion Screw



## HPS Fusion Plates

The OsteoMed® Hand Fusion Plates use the plate screws from OsteoMed's Hand Plating System, combined with a compression screw from the Hand Fusion Module, to provide compression across the proximal interphalangeal (PIP) and metacarpophalangeal (MCP) joints.



The industry's first ExtremiFix™ cannulated compression screw with variable-angle locking capabilities

Fusion Plates	Plate Length	Thickness
Fusion Plate	25 mm	1.6, 2.0 mm

Fusion Screws	Length
2.0 mm Fusion Screw	16–32 mm 2 mm Increments
2.4 mm Fusion Screw	20–36 mm 2 mm Increments

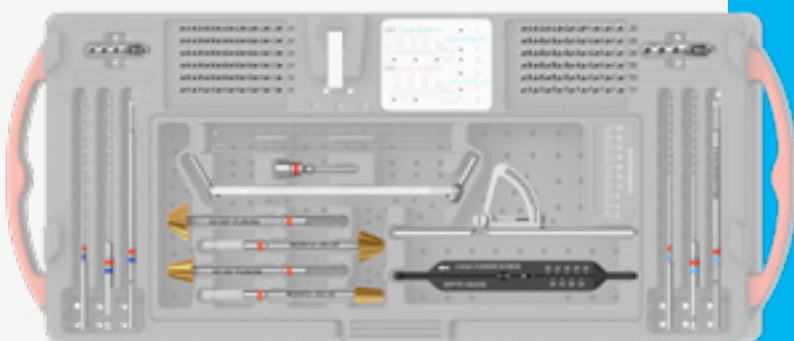

**HPS Fusion Instrument Block**  
 Procedure-specific instruments integrate with the universal instrumentation from OsteoMed's Hand Plating System

# Hand Fracture System

The Acumed Hand Fracture System features both standard and specialty plates for fixation of metacarpal and phalangeal fractures, fusions, and osteotomies.

Standard Plates	Thickness	Length
Compression Plate, 6-hole	0.8 mm	32.3 mm
Compression Plate, 6-hole	1.3 mm	38.3 mm
Straight Plate, 10-hole	0.8 mm	50.2 mm
Straight Plate, 10-hole	1.3 mm	60.2 mm
T-Plate	0.8 mm	50.0 mm
T-Plate	1.3 mm	59.9 mm
Offset Plate	0.8 mm	35.0 mm

Specialty Plates	Thickness	Length
Curved Medial/Lateral Plate	0.8 mm	35.8 mm
Avulsion Hook Plate	0.8 mm	10.0 mm
Metacarpal Neck Plate, Left & Right	1.3 mm	27.8 mm
Rolando Fracture Hook Plate	1.3 mm	34.6 mm
Rotational Correction Plate	1.3 mm	33.7 mm

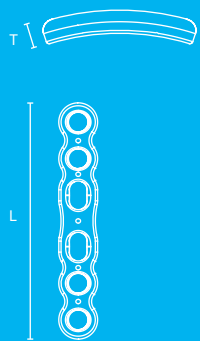

### Specialized Instrumentation

Plate cutter is designed to leave a rounded edge in order to help minimize soft-tissue irritation



The first hand plates on the market that accept multiple screw diameters in every hole of every plate in the system

Standard Plates (blue = 0.8 mm, silver = 1.3 mm)

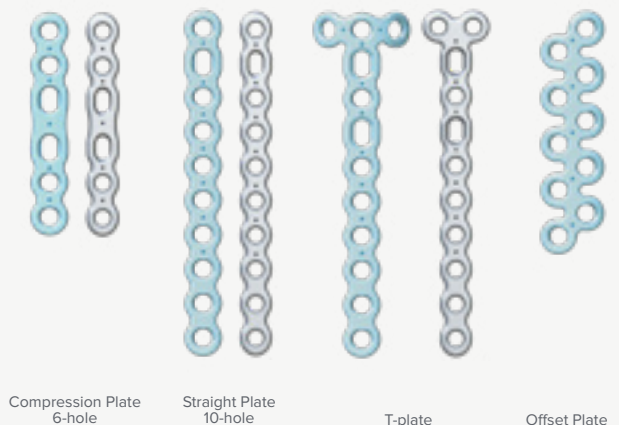

**Customizable**

Fracture-specific and standard plates can be bent to fit and cut to length, providing nearly 100 plate options

**Versatile Hexalobe MultiScrews**

Designed to be used with any plate in the Hand Fracture System, 1.5 mm and 2.3 mm Hexalobe MultiScrews act as nonlocking screws when inserted into unthreaded slots, and locking variable-angle screws when inserted into threaded holes

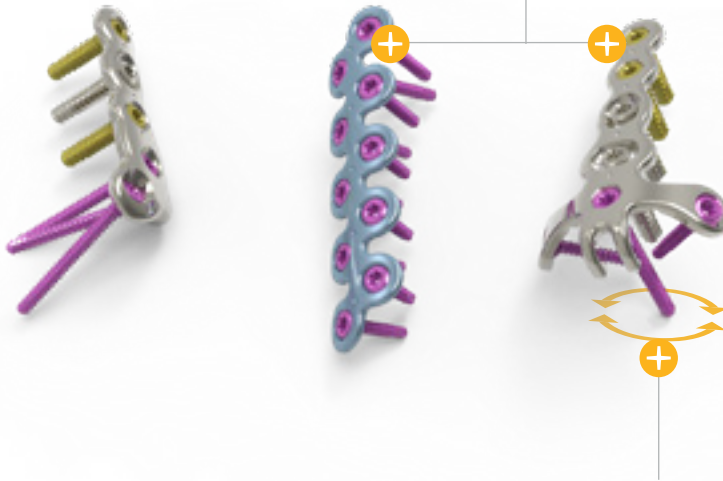

**Specialty Plate Options**

Includes Metacarpal Neck, Rolando Fracture, and Curved Medial/Lateral plates

**Locking Variable Angle Screws**

Hexalobe MultiScrews allow for variable angle screw insertion up to 15 degrees in any direction, for a total of 30 degrees

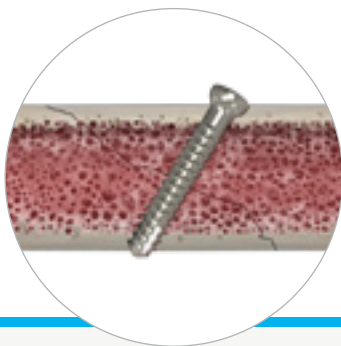
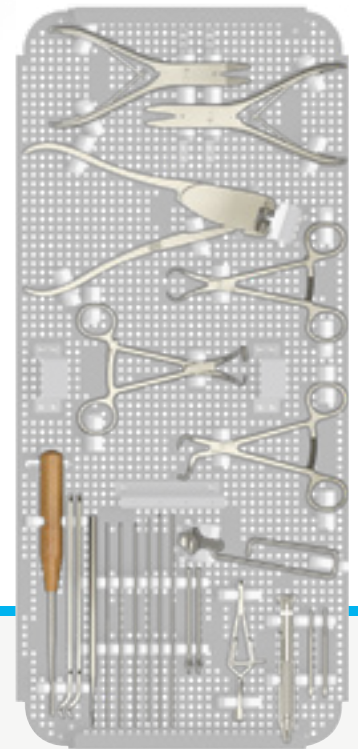

**Hexalobe Lag Screws**

Designed to be used as an adjunct to plate fixation or for fractures that can be treated with lag screws alone. Acumed's 1.5 mm and 2.3 mm Hexalobe Lag Screws do not require overdrilling of the near cortex

**Specialty Plates (blue = 0.8 mm, silver = 1.3 mm)**



Curved Medial/Lateral Plate

Avulsion Hook Plate

Metacarpal Neck Plate

Rolando Fracture Hook Plate

Rotational Correction Plate

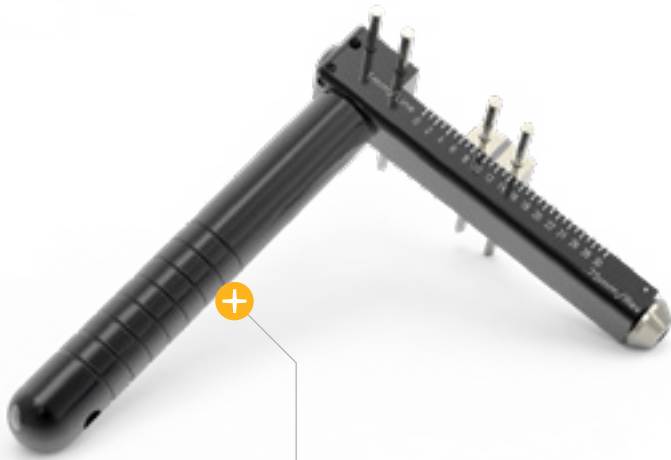

**Small Bone Distractor**

Designed to aid with open or closed fractures, corrective osteotomies, and distraction lengthening of the metacarpals, metatarsals, and phalanges, with a removable handle that facilitates manipulation of the device during K-wire insertion



**Small Bone Fixator**

Stabilizes fractures resulting from high-energy trauma, including fusions, osteotomies, open and/or comminuted fractures, and fractures with length discrepancies



Threaded Single Trocar Guide Wire



Small Bone Distractor



Small Bone Fixator Set



## Small Bone External Fixation System

The Acumed Small Bone External Fixation System was designed for the temporary stabilization of the metacarpals and phalanges. By combining a fixator that aids in reduction and compression with a device designed to maintain distraction forces during fracture healing, the system provides multiple solutions for hand trauma all in one tray.

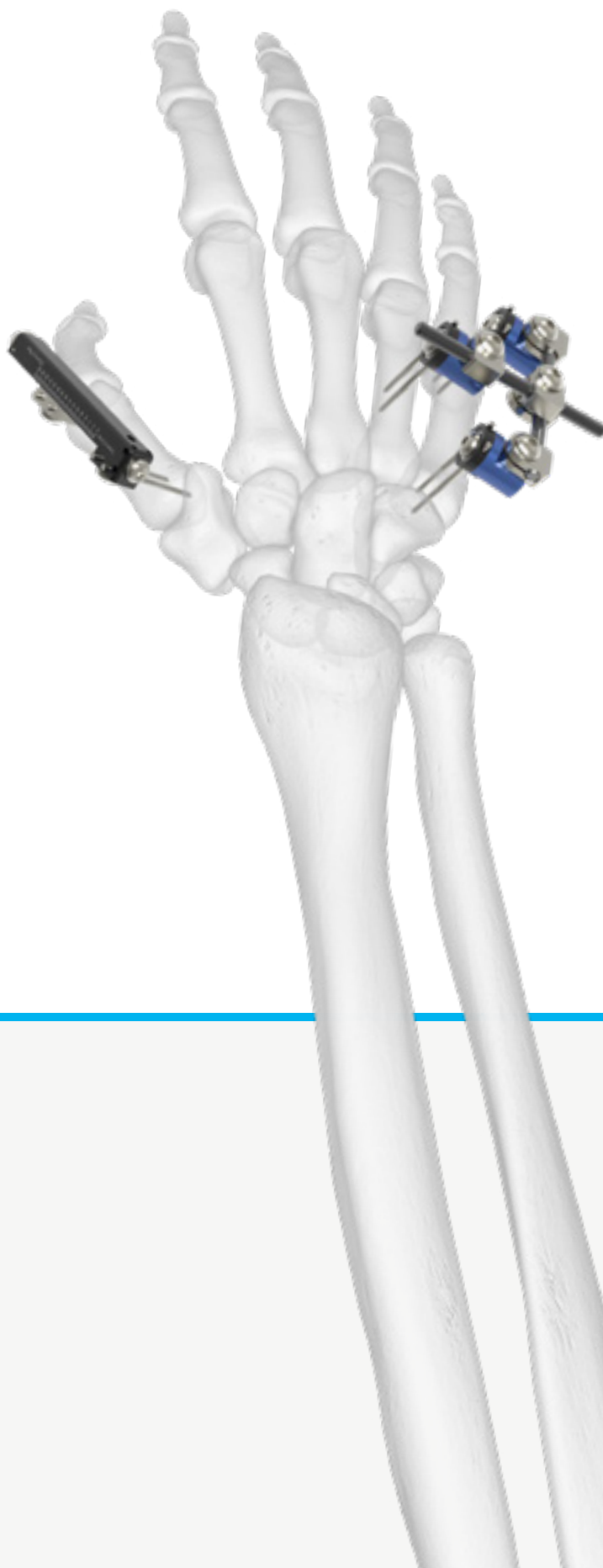

Small Bone Fixator	Length	Material Type
Small Bone Fixator Shaft	60 mm	Carbon Fiber Rod
Small Bone Fixator Shaft	60 mm	Threaded Rod
Small Bone Fixator Shaft	90 mm	Carbon Fiber Rod
Small Bone Fixator Shaft	90 mm	Threaded Rod

Small Bone Distractor	Maximum Distraction
Small Bone Distractor	30 mm

Guide Wire	Length
Threaded Single Trocar Guide Wire	100 mm

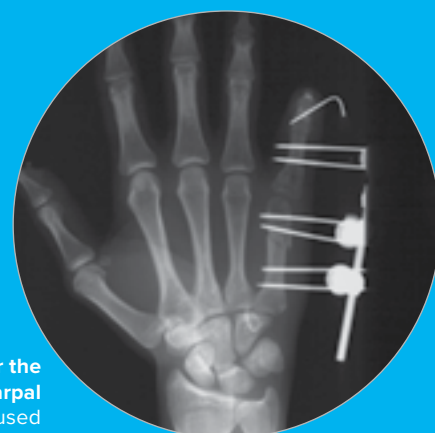

**Fixation for the Fifth Metacarpal**  
Small Bone Fixator used on the fifth metacarpal



# Ulna Nail 2 with Tip-Loc™ Technology

The Ulna Nail 2 is designed to address simple, transverse, and short oblique fractures, and ulna osteotomies. The system includes three nail diameters and seven length options, power reamers, and carbon fiber radiolucent targeting guides to streamline the procedure. It also has threaded holes within the nail, headless hexalobe screws to minimize soft-tissue irritation, and can lock the nail distally.

Ulna Nail 2	Length	Tip Diameter
Ulna Nail	120 mm	3.0, 3.6, 4.0 mm
Ulna Nail	170 mm	3.0, 3.6, 4.0 mm
Ulna Nail	190 mm	3.0, 3.6, 4.0 mm
Ulna Nail	210 mm	3.0, 3.6, 4.0 mm
Ulna Nail	250 mm	3.0, 3.6, 4.0 mm
Ulna Nail	270 mm	3.0, 3.6, 4.0 mm

Tip-Loc	Diameter	Length
Tip-Loc Bushing	6.35 mm	6–16 mm
Set Screw	3.4 mm	6–16 mm

End Caps	Length
Optional End Caps	+0.4 mm
Optional End Caps	+5 mm
Optional End Caps	+10 mm
Optional End Caps	+15 mm

**Note:** Base diameter for all nails is 6.35 mm



### Targeting Guide

The FFN Handle assists with nail insertion, acts as an impactor for the hammer, or can aid in removal by engaging its threads with the nail. The handle also doubles as a tightening device when assembling the targeting guide.

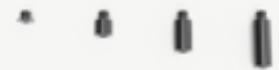

End Caps

**Fixed-Angle Construct**

All screw holes are threaded to provide a fixed-angle construct. Posterior-to-anterior screws target the coronoid and olecranon processes

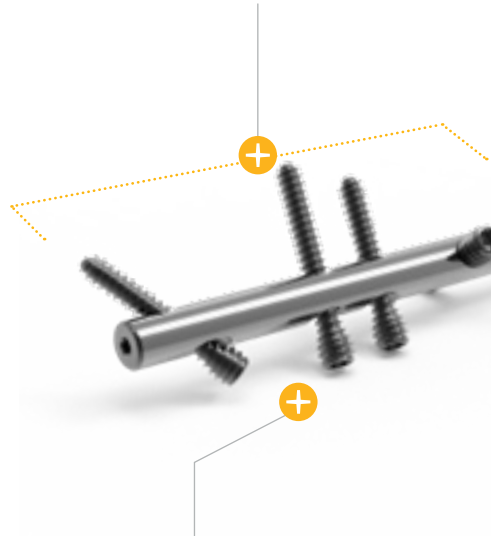

**Low-Profile Screws**

3.5 mm headless hexalobe screws are low-profile and intended to minimize soft-tissue irritation

**Optional Distal Fixation**

Tip-Loc™ Bushing and Set Screw offers the option to lock the nail distally, providing additional fixation within the canal

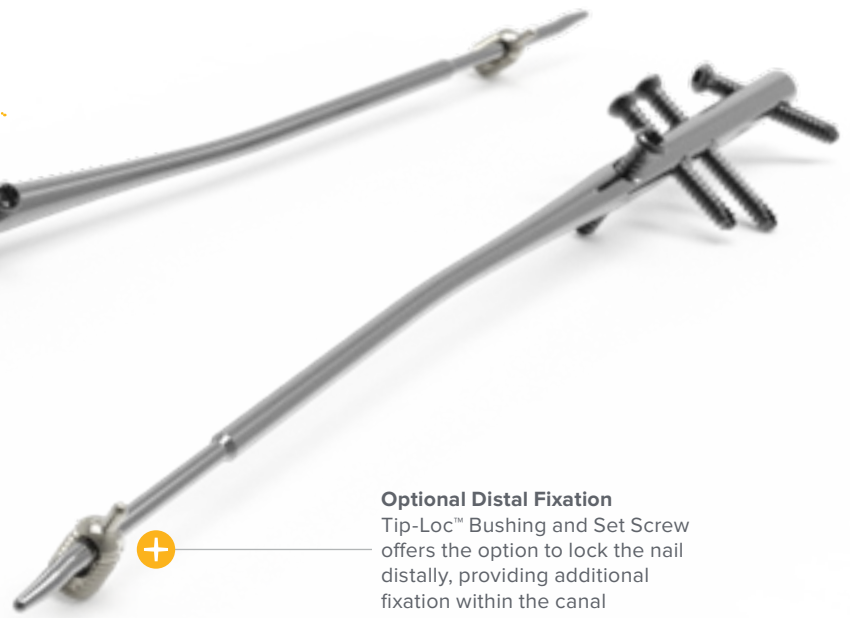

**Tapered Offset Nail Tip**  
Aids in crossing the fracture site



Straight Ulna Nail 2  
3.0, 3.6, 4.0 mm



3.0 mm Ulna Nail 2



3.6 mm Ulna Nail 2



4.0 mm Ulna Nail 2

# Anatomic Midshaft Forearm Plating System

Volar Midshaft Radius Plates, Dorsolateral Midshaft Radius Plates, and Midshaft Ulna Plates in the Acumed Anatomic Midshaft Forearm Plating System are designed to treat fractures, fusions, and osteotomies of the radius and ulna.

Volar Midshaft Radius Plates	Hole Count	Length
Volar Midshaft Radius Plate	6-hole	80 mm
Volar Midshaft Radius Plate	8-hole	100 mm
Volar Midshaft Radius Plate	10-hole	130 mm
Volar Midshaft Radius Plate	12-hole	160 mm
<b>Opt*</b> Volar Midshaft Radius Plate	14-hole	180 mm
<b>Opt*</b> Volar Midshaft Radius Plate	16-hole	210 mm

Dorsolateral Midshaft Radius Plates	Hole Count	Length
Dorsolateral Midshaft Radius Plate	6-hole	80 mm
Dorsolateral Midshaft Radius Plate	8-hole	100 mm
Dorsolateral Midshaft Radius Plate	10-hole	130 mm
Dorsolateral Midshaft Radius Plate	12-hole	160 mm
<b>Opt*</b> Dorsolateral Midshaft Radius Plate	14-hole	180 mm
<b>Opt*</b> Dorsolateral Midshaft Radius Plate	16-hole	210 mm

Midshaft Ulna Plates	Hole Count	Length
Midshaft Ulna Plate	6-hole	80 mm
Midshaft Ulna Plate	8-hole	100 mm
Midshaft Ulna Plate	10-hole	130 mm
Midshaft Ulna Plate	12-hole	160 mm
<b>Opt*</b> Midshaft Ulna Plate	14-hole	180 mm
<b>Opt*</b> Midshaft Ulna Plate	16-hole	210 mm

\*Opt: Optional, sterile-packed only



Launched in 2008, the Acumed Anatomic Midshaft Forearm Plating System introduced the first precontoured radius plates on the market.



### Precontoured Plates

Precontoured plates are intended to minimize the need for intraoperative plate bending to help save operating time. This allows surgeons to focus on restoring anatomy and reestablishing forearm pronation-supination.<sup>1</sup>

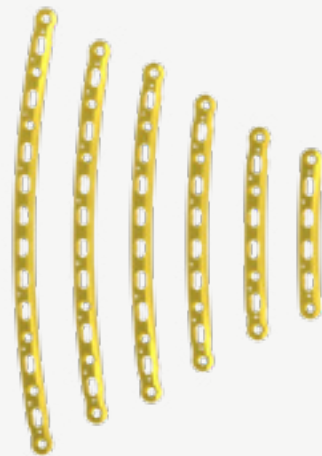
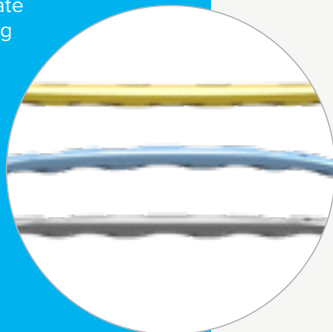

Volar Midshaft Radius Plates

1. Rupasinghe S, Poon P. Radius morphology and its effects on rotation with contoured and noncontoured plating of the proximal radius. *J Shoulder Elbow Surg.* 2012;21: 568-573.

**Low-profile Design**

The low screw-plate interface is engineered to minimize soft-tissue irritation

**Limited-contact Undersurface**

Designed to ease compression of the periosteum

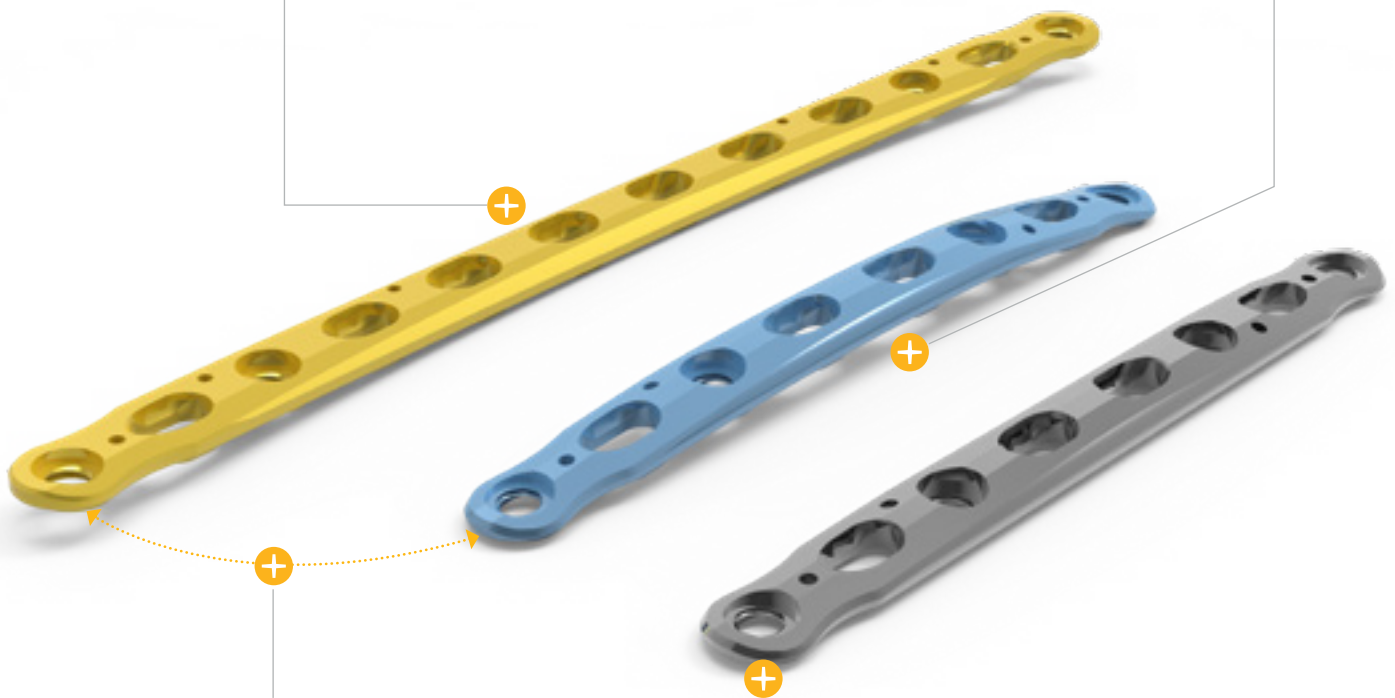

**Approach-specific Radius Plates**

Plates offer either a dorsolateral or volar approach to radial fractures

**Tapered Ends**

Designed to minimize stress on bone and the risk of refracture above or below the plate

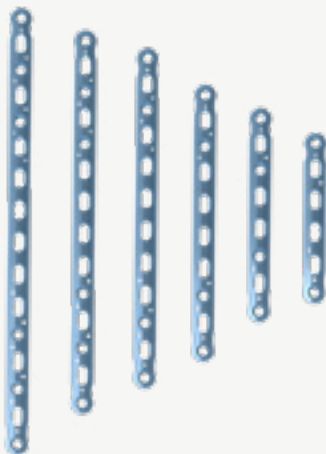

Dorsolateral Midshaft Radius Plates

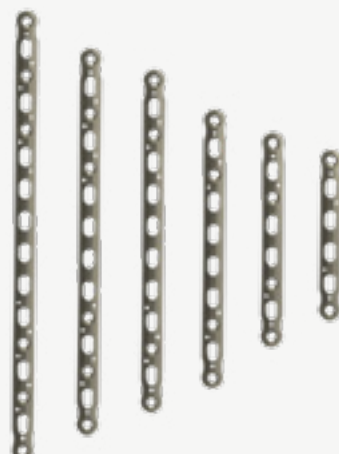

Midshaft Ulna Plates

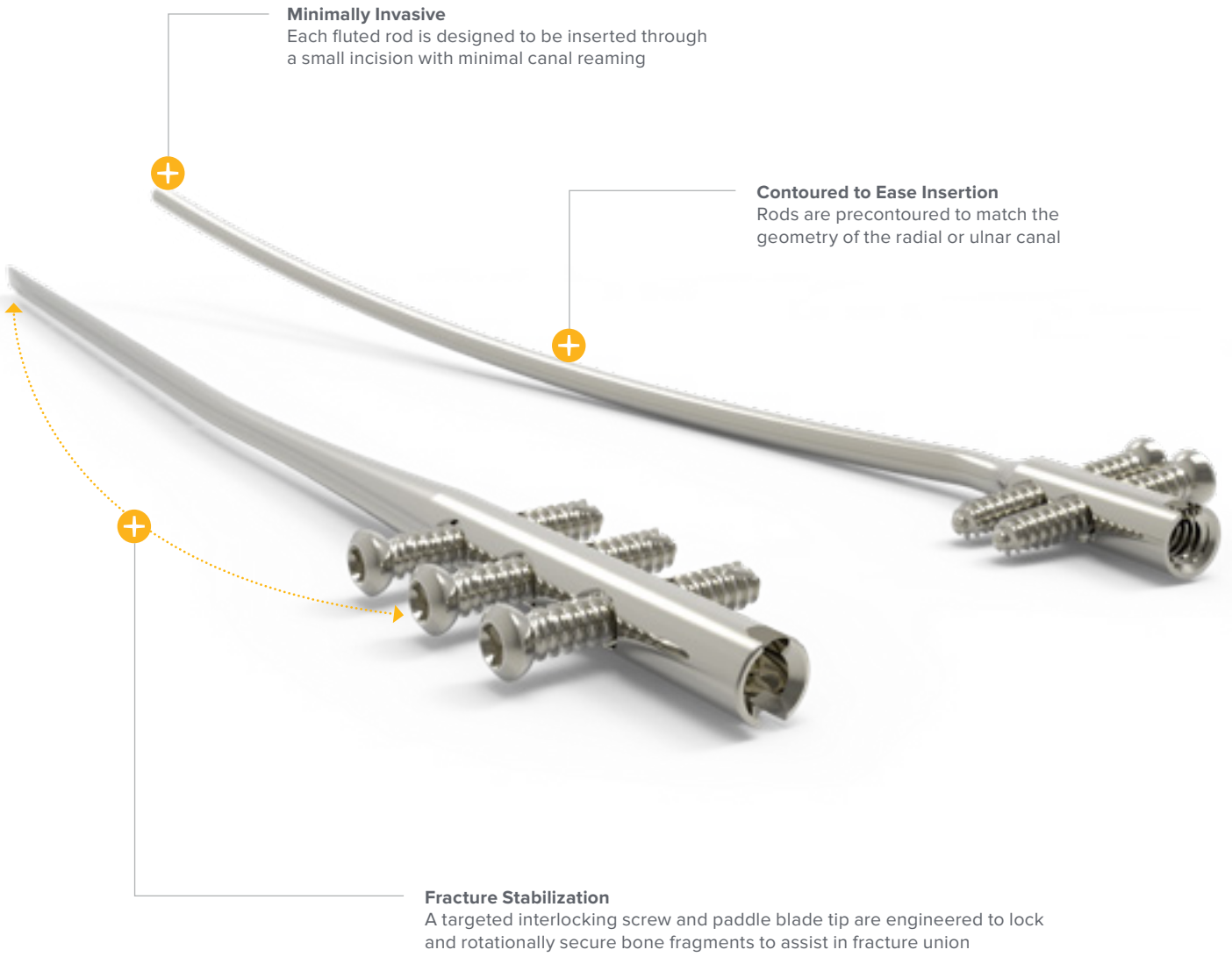

**Minimally Invasive**  
Each fluted rod is designed to be inserted through a small incision with minimal canal reaming

**Contoured to Ease Insertion**  
Rods are precontoured to match the geometry of the radial or ulnar canal

**Fracture Stabilization**  
A targeted interlocking screw and paddle blade tip are engineered to lock and rotationally secure bone fragments to assist in fracture union

3.0 mm Tip Diameter

3.6 mm Tip Diameter

3.0 mm Tip Diameter

3.6 mm Tip Diameter



Ulna Rods



Radius Rods



## Forearm Rod System

The Acumed Forearm Rod System offers an intramedullary approach to address fractures and osteotomies of the radius and ulna. Implants are offered in a variety of diameters and lengths to suit varying patient anatomies. The minimally invasive technique may reduce surgical exposure and total operating time compared to traditional open reduction internal fixation (ORIF).<sup>1</sup>

Ulna Rods	Length	Tip Diameter
Ulna Rod	210 mm	3.0 mm
Ulna Rod	230 mm	3.0 mm
Ulna Rod	250 mm	3.0 mm
Ulna Rod	270 mm	3.0 mm
Ulna Rod	210 mm	3.6 mm
Ulna Rod	230 mm	3.6 mm
Ulna Rod	250 mm	3.6 mm
Ulna Rod	270 mm	3.6 mm

Radius Rods	Length	Tip Diameter
Radius Rod, Left & Right	190 mm	3.0 mm
Radius Rod, Left & Right	210 mm	3.0 mm
Radius Rod, Left & Right	230 mm	3.0 mm
Radius Rod, Left & Right	190 mm	3.6 mm
Radius Rod, Left & Right	210 mm	3.6 mm
Radius Rod, Left & Right	230 mm	3.6 mm

**Note:** Base diameter for all rods is 6 mm



**Radiolucent Targeting Guide**  
The interlocking screws can be inserted through slit incisions and implanted using the targeting guide



1. Lee YH, Lee SK, Chung MS, Baek GH, Gong HS, Kim KH. Interlocking contoured intramedullary nail fixation for selected diaphyseal fractures of the forearm in adults. *J Bone Joint Surg Am.* 2008;90:1891-1898.

## Acu-Loc® 2 Wrist Plating System

The Acumed Acu-Loc 2 Wrist Plating System offers 48 plate options, including distal and proximal sitting plates, three different plate extension options, and fragment-specific plating choices. Innovative instrumentation includes a targeting guide with radiopaque markings that allow visualization of anticipated screw trajectories.

Acu-Loc 2 Volar Distal Radius (VDR) Plates	Length	Width
VDR Proximal Standard, Left, Right	49 mm	24 mm
VDR Proximal Narrow, Left, Right	49 mm	24 mm
VDR Proximal Wide, Left, Right	57 mm	27 mm
VDR Proximal Standard Long, Left, Right	65 mm	21 mm
VDR Proximal Narrow Long, Left, Right	65 mm	21 mm

VDR Proximal Extension Plate Neutral	108 mm	NA
VDR Proximal Extension Plate Long, Left, Right	167 mm	NA

VDR Standard, Left, Right	51 mm	25 mm
VDR Narrow, Left, Right	51 mm	22 mm
VDR Wide, Left, Right	59 mm	29 mm
VDR Standard Long, Left, Right	68 mm	25 mm
VDR Plate Narrow Long, Left, Right	68 mm	22 mm

Acu-Loc 2 Extra-articular (EX) Plates	Length	Width
EX Standard	53 mm	25 mm
EX Narrow	46 mm	20 mm

Acu-Loc Dorsal Radius Locking Plates	Length	Width
Dorsal Plate, Standard, Left, Right	55 mm	28 mm
Dorsal Plate, Narrow, Left, Right	55 mm	23 mm

Distal Radius Fragment Specific (DRFS) Plates	Length	Width
Divergent Radial Styloid Plate	46 mm	6 mm
Volar Lunate Suture Plate	44 mm	14 mm
Dorsal Rim Buttress Plate, Left, Right	43 mm	33 mm
Dorsal Lunate Plate, Left, Right	43 mm	12 mm

Acu-Loc Volar Distal Ulna (VDU) Plates	Length	Width
VDU Plate, Long, Left, Right	66 mm	14 mm
VDU Plate, Standard, Left, Right	45 mm	14 mm

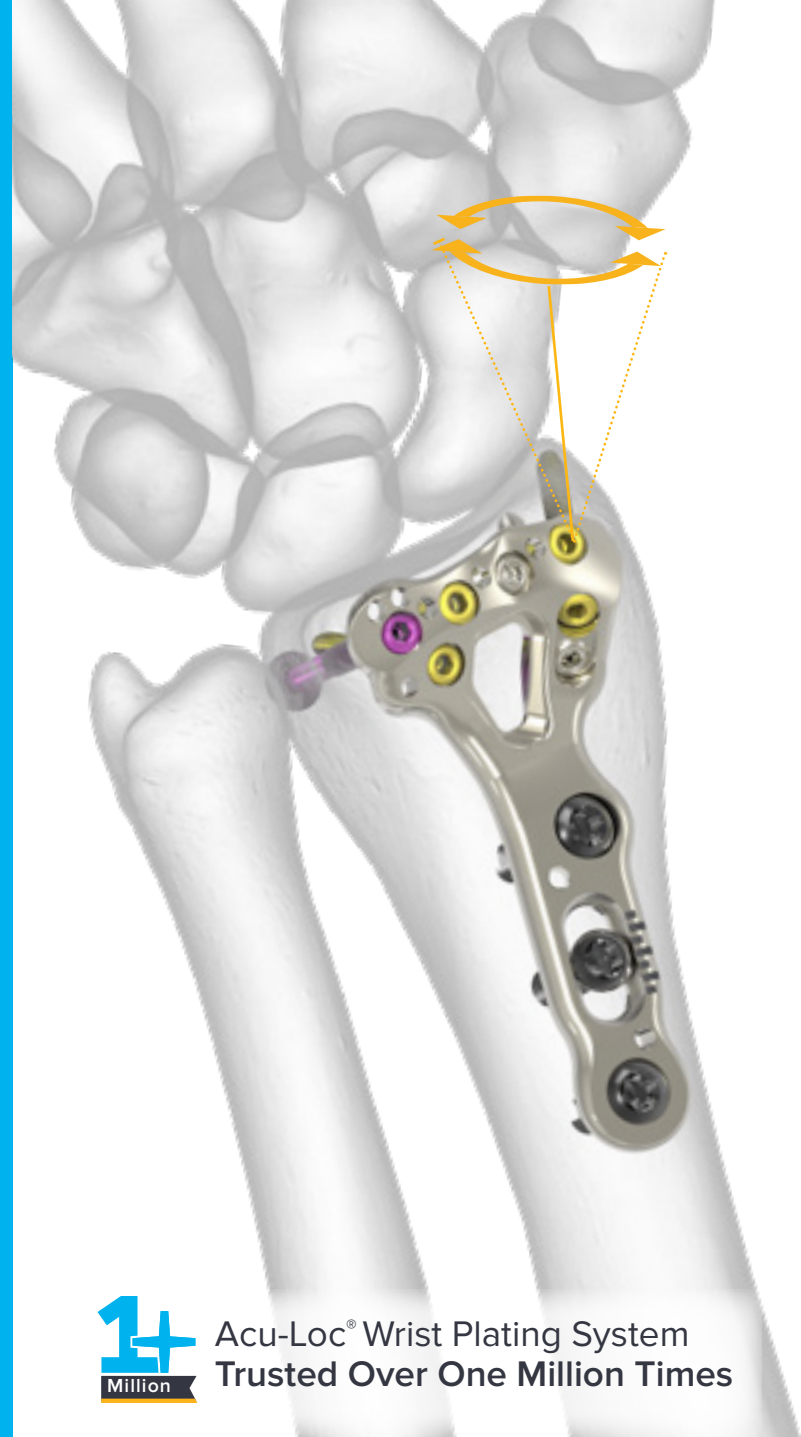
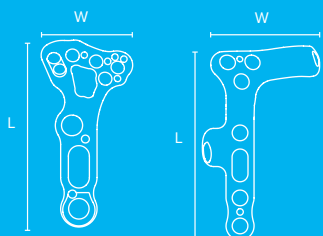

**1+**  
Million  
Acu-Loc® Wrist Plating System  
Trusted Over One Million Times

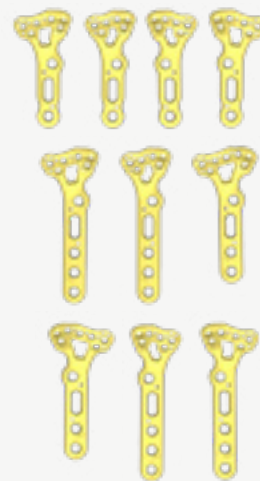

Volar Distal Radius Proximal Plates



Volar Distal Radius Proximal Extension Plates

**2.3 mm Fixed-angle Screws and Pegs**  
For targeted subchondral bone support, including two dedicated styloid screws

**Streamlined Distal Radius Fixation**  
3.5 and 2.7 mm screws are available for the shaft. The 2.7 mm screws use the 2.0 mm Quick Release Drill, designed to streamline distal radius fixation

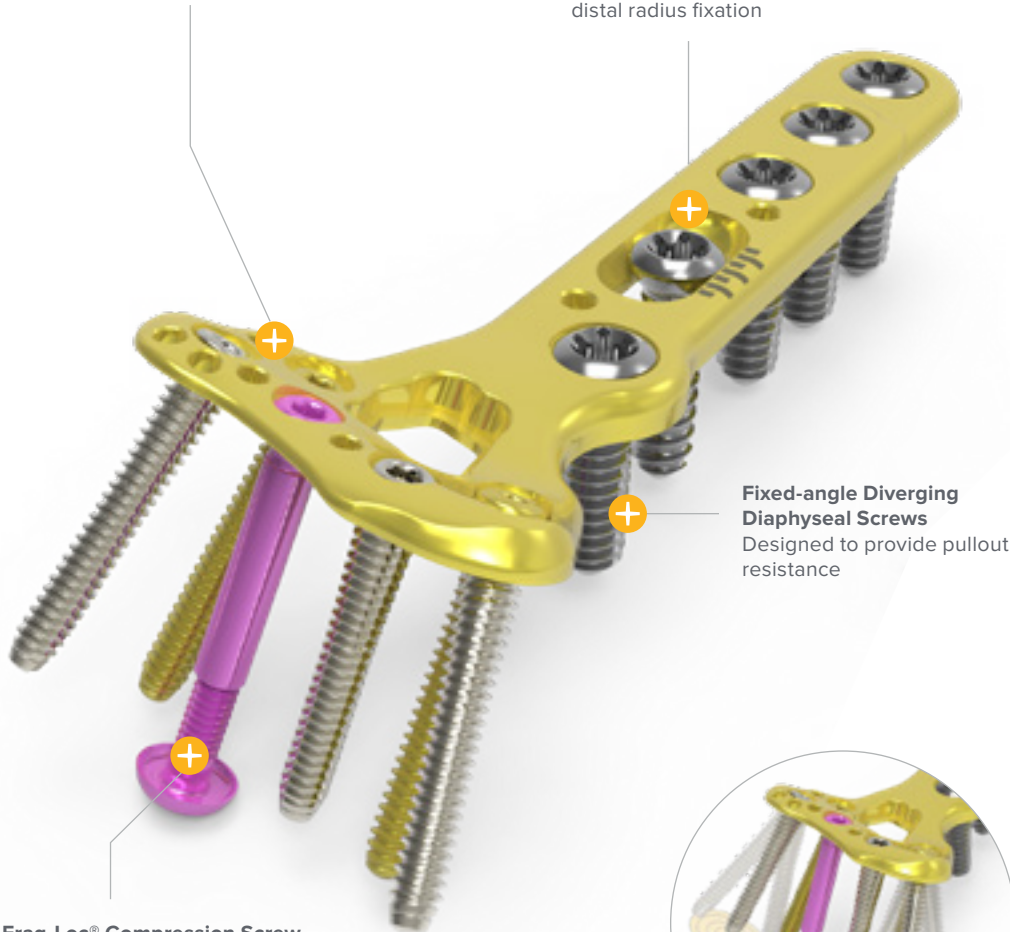
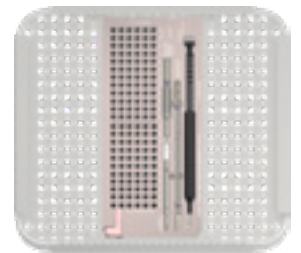
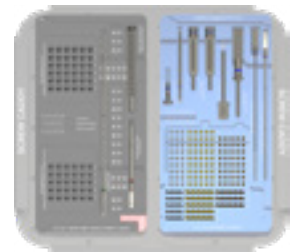

**Fixed-angle Diverging Diaphyseal Screws**  
Designed to provide pullout resistance

**Frag-Loc® Compression Screw**  
A two-part cannulated screw designed to compress dorsal fragments

**Variable Angle Screws**  
2.3 mm locking variable angle screws assist to capture specific fragments and accommodate variable patient anatomy

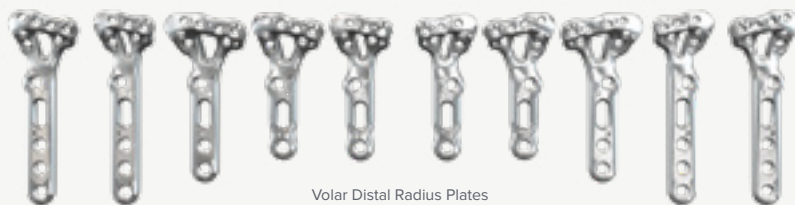

Volar Distal Radius Plates



Extra-Articular Plates



Dorsal Radius Locking Plates



Distal Radius Fragment Specific Plates



Volar Distal Ulna Plates



**1+** Million  
**Acu-Loc® Wrist Plating System**  
**Trusted Over One Million Times**

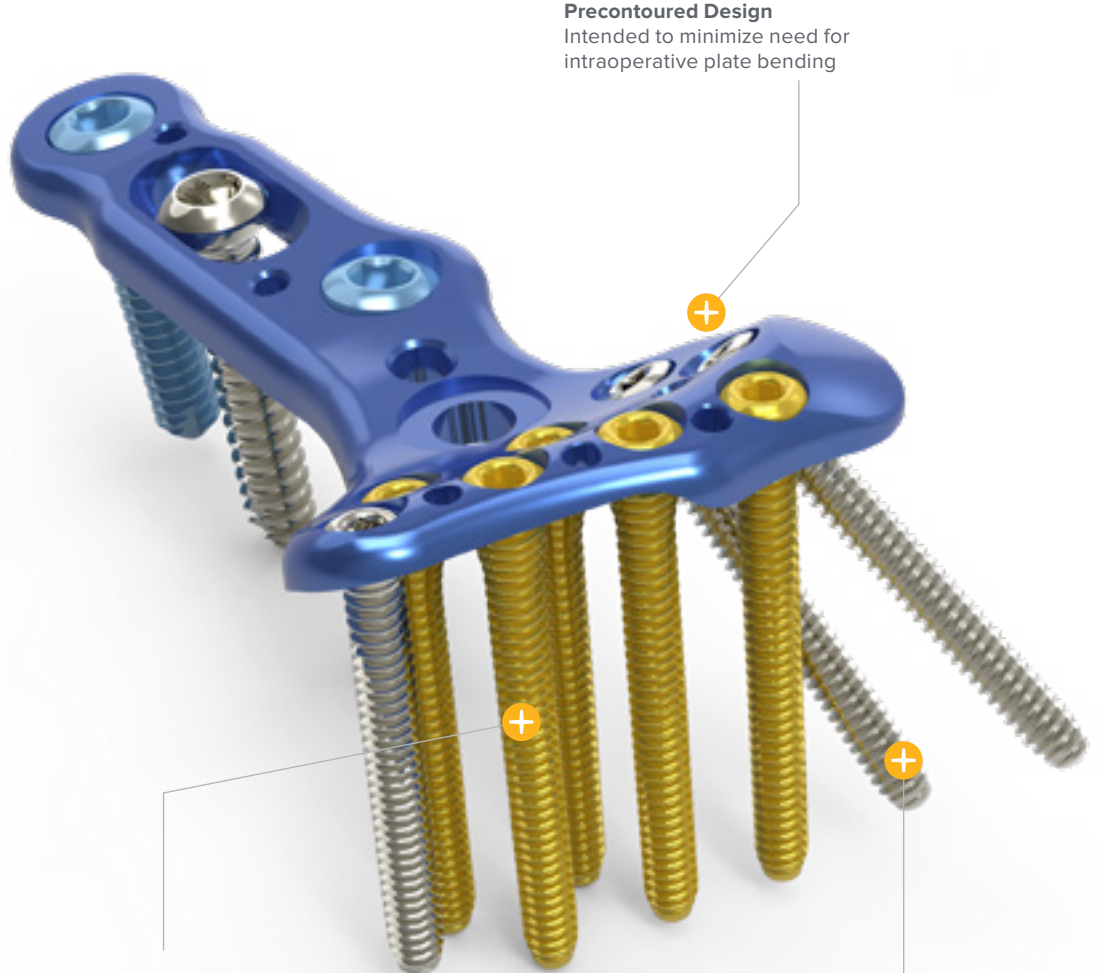
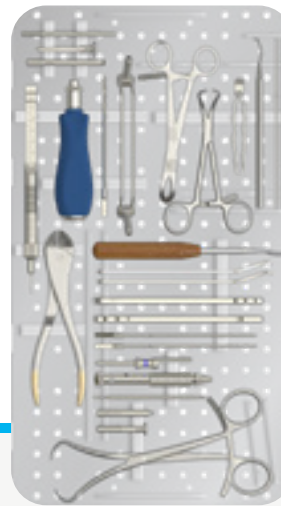
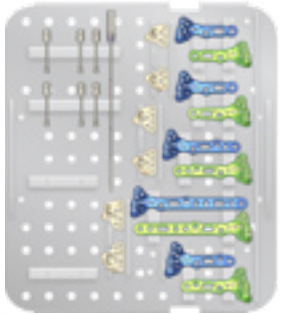
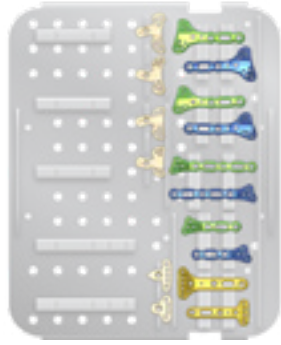

**Precontoured Design**  
 Intended to minimize need for intraoperative plate bending

**Fixed-angle Screws**  
 Designed to target the densest subchondral bone in the radial and intermediate columns of the distal radius

**Distal Screws**  
 Angled forward 6 degrees from the plate, distal screws are designed to maximize purchase in the subchondral bone to increase pullout strength

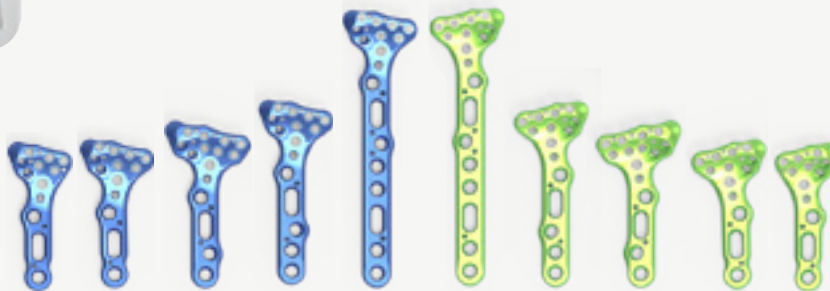

Volar Distal Radius Plate



Extra-articular Plates



Dorsal Radius Locking Plates



Volar Distal Ulna Plates

## Acu-Loc® Wrist Plating System

To address a wide range of fractures, fusions, and osteotomies, the Acumed Acu-Loc Wrist Plating System offers four families of precontoured titanium plates designed to minimize the need for intraoperative plate bending to help save operating time. This allows surgeons to focus on restoring anatomy and reestablishing forearm pronation-supination.

Acu-Loc Volar Distal Radius (VDR) Plates	Length	Width
VDR Standard, Left, Right	51 mm	25 mm
VDR Narrow, Left, Right	51 mm	22 mm
VDR Wide, Left, Right	57 mm	29 mm
VDR Long, Left, Right	64 mm	25 mm
VDR X-Long, Left, Right	95 mm	25 mm

Acu-Loc Dorsal Radius Locking Plates	Length	Width
Dorsal Plate, Standard, Left, Right	55 mm	28 mm
Dorsal Plate, Narrow, Left, Right	55 mm	22 mm

Acu-Loc Extra-articular (EX) Plates	Length	Width
EX, Standard	53 mm	25 mm
EX, Narrow	46 mm	25 mm

Acu-Loc Volar Distal Ulna (VDU) Plates	Length	Width
VDU Plate, Long, Left, Right	66 mm	14 mm
VDU Plate, Standard, Left, Right	45 mm	14 mm

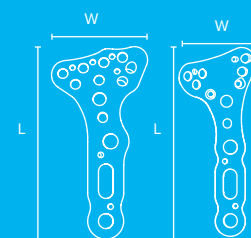

### Radiolucent Targeting Guide

The monoblock guide allows surgeons to drill, measure, and insert screws without removing the guide

### Volar Distal Ulna (VDU) Plates

Designed specifically for periarticular fractures of the distal ulna, the plate features screw positioning and angulation that targets distal fragments of the ulnar head and neck; 3.5 and 2.7 mm screws are available for the shaft



## Acu-Loc® Wrist Spanning Plate

The Acumed Acu-Loc Wrist Spanning Plate is designed to address complex distal radius fractures. This temporary fixator holds the wrist in distraction and provides ligamentotaxis to the wrist while the distal radius heals.

Acu-Loc Wrist Spanning Plates	Length	Radial Shaft Length	Metacarpal Length
Wrist Spanning Plate, Short	171 mm	100 mm	71 mm
Wrist Spanning Plate, Long	188 mm	100 mm	88 mm

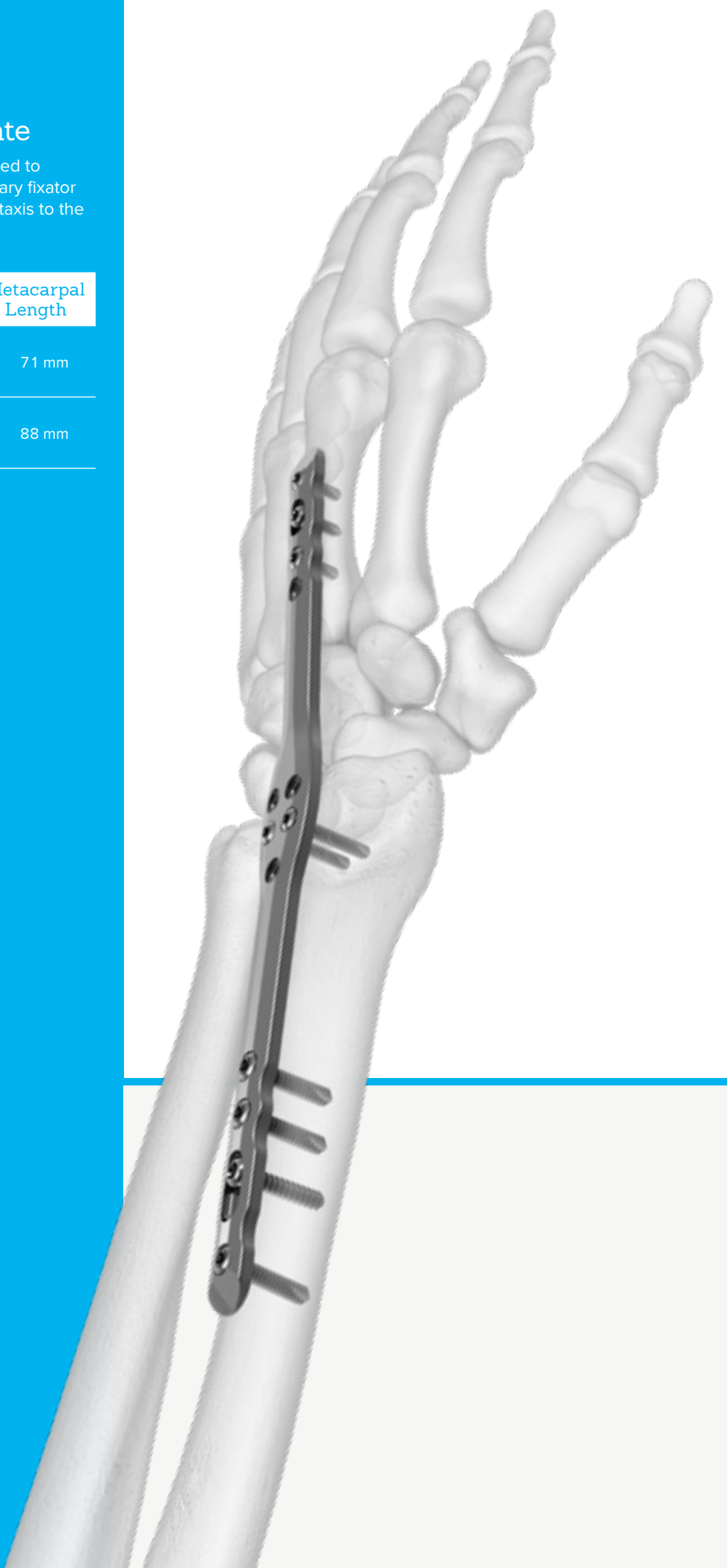
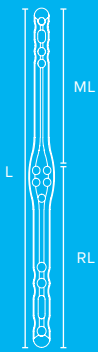

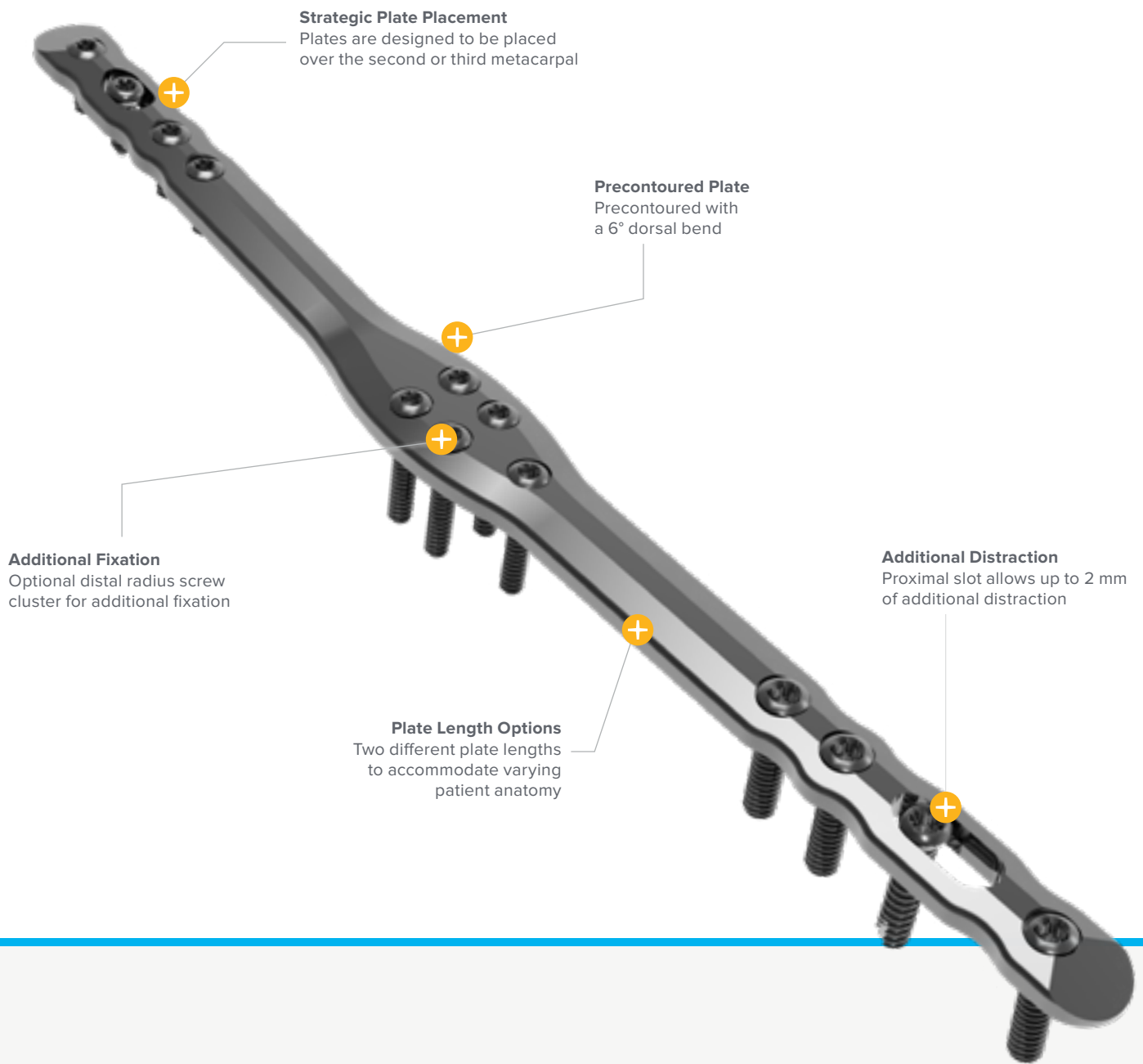

# ExtremiLock™ Wrist Plating System

The OsteoMed® ExtremiLock Wrist Plating System includes the latest in variable-angle locking screw and plate technology to treat multiple reconstructive and trauma applications of the distal radius. It is intended for fracture fixation, fusion, and osteotomies of the wrist and other bones appropriate for the size of the device. Implants are intended for single-use only.

VDR Narrow Plate	Length	Width
1-Hole VDR Short Narrow Plate, Left and Right	33 mm	21 mm
4-Hole VDR Narrow PQ Sparing, Left and Right	60 mm	22 mm

VDR Standard Plate	Plate Length	Thickness
1-Hole VDR Standard Plate, Left and right	33 mm	25 mm
4-Hole VDR Standard Plate, Left and Right	54 mm	25 mm
7-Hole VDR Standard Plate, Left and Right	75 mm	25 mm
4-Hole VDR Standard PQ Sparing, Left and Right	62 mm	24 mm

Sterile-packed Plates	Plate Length	Thickness
VDR Radial Column Standard, Left and Right	36 mm	12 mm
VDR Intermediate Column Standard, Left and Right	36 mm	12 mm
6-Hole Radial Styloid Plate	38 mm	8 mm



**Target Drill Guide**

Attach the corresponding radiolucent target drill guide to the plate using the set screw and driver stem. Drill can be attached prior to plate placement



VDR Intermediate Column Standard



Radial Column Standard



Radial Styloid Plate, Sterile

**Variable Angle**  
Locking screw head designed to sit below the plate surface even at end-range angles

**Short Volar Distal Radius (VDR) Plate**  
Designed to treat intraarticular fractures; the plate can be implanted with a smaller incision compared to a standard volar plate

**Cannulated Variable Angle Screw**  
Cannulated double-lead locking compression screw captures dorsal fragments through a universal screw hole or as a compression screw outside of the plate

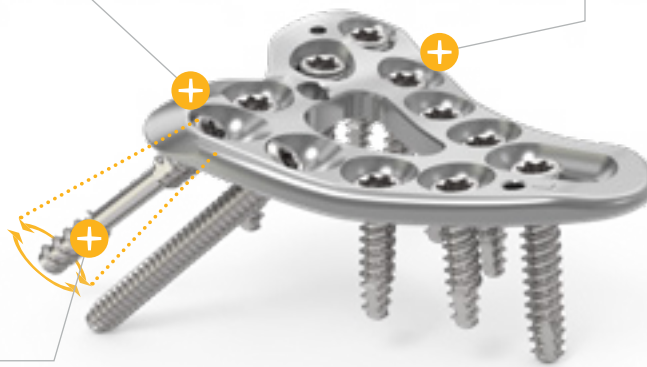

**Pronator Quadratus (PQ) Sparing VDR Plate**  
Allows for minimal dissection of the PQ muscle and accurate screw implantation using the spanning and bone-centering drill guide



VDR Narrow Short Plate



VDR Narrow Plate



VDR Narrow PQ Sparing



VDR Standard Short Plate



VDR Standard Plate



VDR Standard PQ Sparing

**Reference Lines**

Helps facilitate the osteotomy when a freehand cut is preferred; 40° oblique laser lines and perpendicular lines are spaced 2 mm apart

**Cutting Guide**

Offers continuous adjustment from 1 mm to 10 mm, allowing a resection of the amount desired

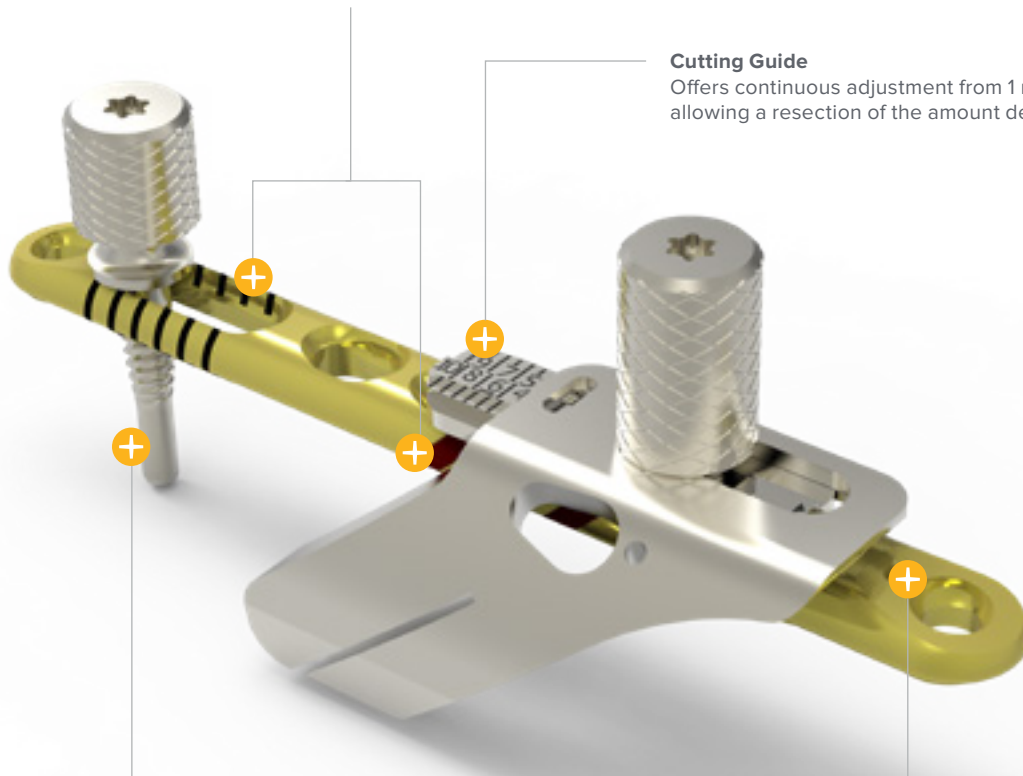

**Ulna Shortening Reduction Peg**

Stabilizes the ulna and helps maintain rotational alignment while creating the osteotomy prior to being used with the reduction clamp

**Versatile Construct**

The ulna shortening plate features the ability to lock up to 3 screws distally and 1 proximally, and 2 scalloped holes that accommodate a lag screw across the osteotomy site

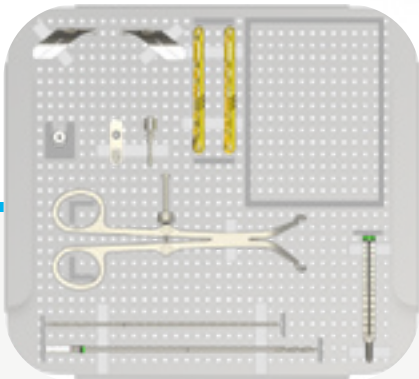

**Choice of Saw Blades**

Three sagittal saw blade options suit different power couplings, expanding surgeon options



Osteotomy Plate

Hub Style L

Hub Style S

Hub Style DS



## Osteotomy System

The Acumed Osteotomy System features the Ulna Shortening Plate, with built-in osteotomy reference lines and a cutting guide. The interfragmentary lag screw can be placed in one of two locations to securely compress the osteotomy.

Osteotomy Plate	Length	Width
Ulna Shortening Plate, 6-hole	85 mm	10 mm distally 8.8 mm proximally

Sagittal Saw Blade	Shaft Thickness	Kerf Thickness	Cutting Depth
Hub Style L	.5 mm	.63 mm	25 mm
Hub Style S	.5 mm	.63 mm	25 mm
Hub Style DS	.5 mm	.63 mm	25 mm

**Note:** The Acumed Osteotomy System can be used with the following Acumed systems to access additional instrumentation not included in this tray: Clavicle Plating System, Elbow Plating System, and Acu-Loc® 2 System.



The Acumed Osteotomy System introduced the first adjustable cutting guide for ulna shortening in 2010.



### Advanced Instrumentation

The Ulna Shortening Reduction Clamp utilizes a speed-lock wheel designed to help maintain a hands-free compression of the osteotomy, in combination with the Ulna Shortening Reduction Peg and a locking drill guide

**Vertical and Horizontal Positioning**  
Can rotate to a horizontal position to provide access to treating distal radius and other hand and wrist fractures

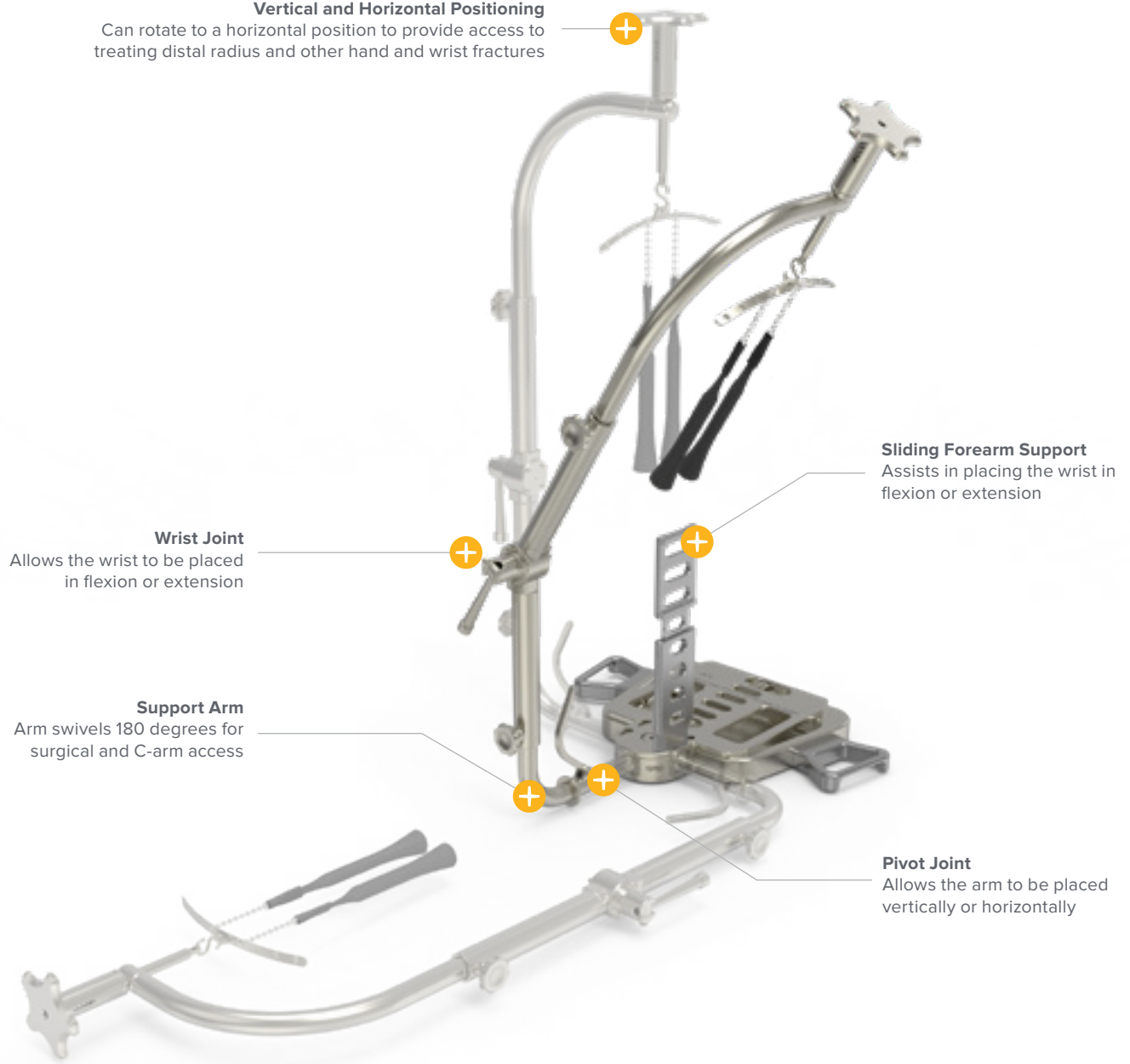

**Wrist Joint**  
Allows the wrist to be placed in flexion or extension

**Support Arm**  
Arm swivels 180 degrees for surgical and C-arm access

**Sliding Forearm Support**  
Assists in placing the wrist in flexion or extension

**Pivot Joint**  
Allows the arm to be placed vertically or horizontally



Fitted Finger Traps



Arm Strap

## Arc Wrist Tower

The Acumed Arc Wrist Tower is designed to provide stable traction of the patient's forearm and hand, allowing unrestricted access to the wrist during arthroscopic and fracture-reduction procedures. The support arm swivels 180 degrees to allow fluoroscopic imaging from any angle.

### Features

Vertical Scoping

Horizontal Scoping

Surgical Access

Versatile Fluoroscopic Imaging

Ulnar Side Access

Fitted Finger Traps Available in Small, Medium, Large, and Extra Large

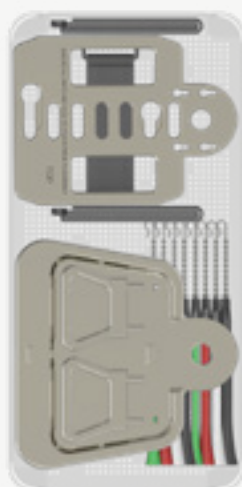
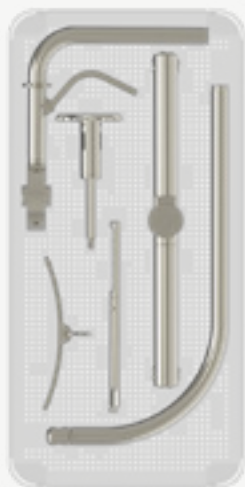

**Spring Scale**  
Contains reference lines in 10-pound increments

## Total Wrist Fusion Plating System

The Acumed Total Wrist Fusion Plating System is designed for wrist arthrodesis due to deformities associated with degenerative arthritis, brachial plexus palsies, and spastic disorders. This five-plate system features both innovative and traditional designs.

Total Wrist Fusion Plates	Length	Ulnar Deviation	Dorsal Bend
Total Wrist Fusion Plate, Small, Left, Right	106 mm	10°	15°
Total Wrist Fusion Plate, Standard, Left, Right	108 mm	10°	15°
Total Wrist Fusion Plate, Neutral, Left, Right*	106 mm	0°	15°

\* The neutral plate is designed to be used in conjunction with a proximal row carpectomy.

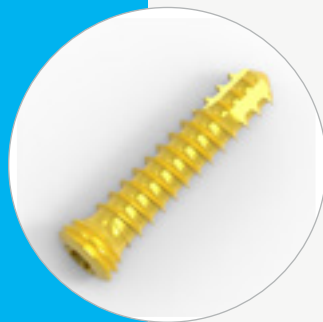
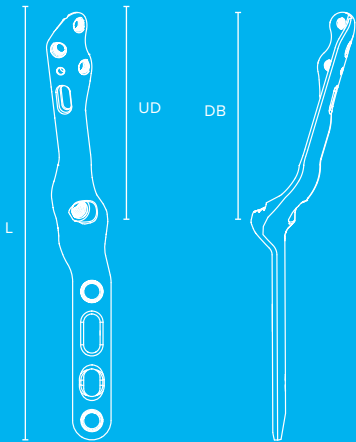

### 2.3 mm Hexalobe MultiScrew

Serves as a nonlocking screw in the non-threaded slots and as a locking screw in the threaded holes

1. Field J, Herbert TJ, Prosser R. Total wrist fusion: a functional assessment. *J Hand Surg Am.* 1996;21B(4): 429-433.

**15° Dorsal Bend**

Plates provide 15 degrees of dorsiflexion and 0–10 degrees of ulnar deviation, intended as a balance between anatomic resting position, hand function, and grip strength¹



**Carpal Cross-screw**

Designed to offer additional implant stability

**Converging Distal Screws**

Designed to assist with pullout resistance

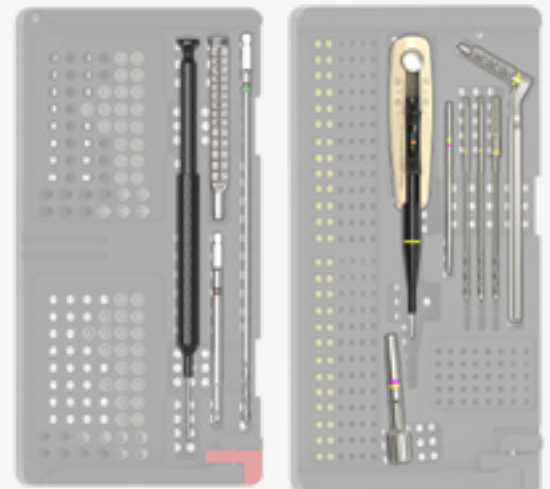
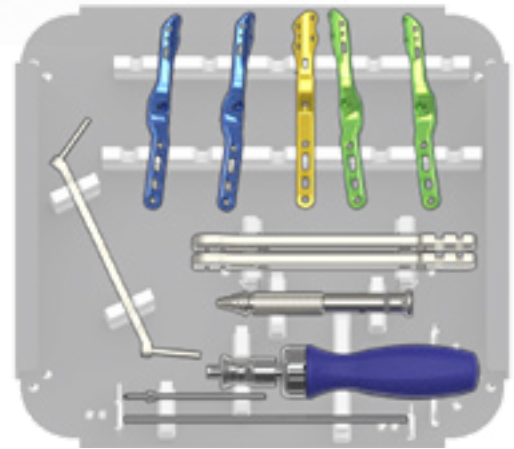

Total Wrist Fusion Plating System



**Hub Cap®  
Limited Wrist Fusion Plate**

*Single Hole*

Acts as a dedicated starting point for screw placement, targeting the hamate

*Scalloped Holes*

Enables placement of either 1 or 2 nonlocking screws into each carpal, per surgeon preference

*Center Hole for Plate Post*

Allows the Hub Cap Plate Post to be used for provisional stability, leaving space to pack in bone graft when removed

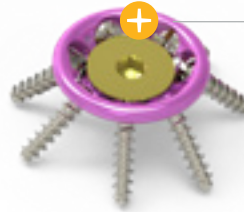

**Mini Hub Cap 4-C  
Limited Wrist Fusion Plate**  
Features a reduced diameter to accommodate smaller patient anatomies

**Mini Hub Cap STT  
Limited Wrist Fusion Plate**

Is the only plate in the Hub Cap family that offers 9 different options for up to 6 screws to be placed in 3-corner fusions

**Hub Cap Screw Cover**

Minimizes screw migration and makes the plate a locked construct, if desired

**MCP Fusion Plate**

Designed for fusions of the first metacarpophalangeal (MCP) joint of the thumb. Left (blue) and right (green) specific plates are engineered to offer stability for arthritis or chronic instability of the MCP or carpometacarpal (CMC) joint



Hub Cap  
Limited Wrist Fusion Plate



Mini Hub Cap STT  
Limited Wrist Fusion Plate



Mini Hub Cap 4-C  
Limited Wrist Fusion Plate



Hub Cap Screw Cover

## Modular Hand System

The Acumed Modular Hand System offers a variety of straightforward fracture and fusion solutions designed to address osteoarthritis, carpal instability, revision of failed partial wrist fusions, and rheumatoid arthritis.



Hub Cap® Plates	Diameter	Carpal Screws
Hub Cap Limited Wrist Fusion Plate	17 mm	Up to 7
Mini Hub Cap STT Limited Wrist Fusion Plate	15 mm	Up to 6
Mini Hub Cap 4-C Limited Wrist Fusion Plate	15 mm	Up to 7
Hub Cap Screw Cover	8.1 mm	

MCP Plate	Length
MCP Fusion Plate, Left & Right	45.7 mm

Screws	Diameter
Nonlocking Screws	2.1 mm and 2.7 mm

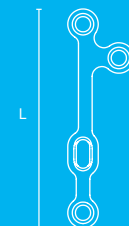

MCP Fusion Plate

### Dual-purpose Reamer

Designed to capture and contain bone debris as it creates the spherical depression to prepare the fusion site for the Hub Cap and Mini Hub Cap Plates. A unique bone graft harvester is designed to harvest autograft from the distal radius and iliac crest

## Stableloc External Fixation System

Acumed offers the Stableloc External Fixation System for treatment of distal radius fractures. The Stableloc External Fixator is designed to hold pins in place for fracture reduction or distraction to align the wrist and to provide ligamentotaxis while the distal radius heals. The system is sterile-packaged with all instruments and pins needed to complete a case. It is designed to be lightweight.

Self-Drilling Pins	Length
3.2 mm x 30 mm Self-Drilling Pin	83 mm
2.7 mm x 25 mm Self-Drilling Pin	75 mm



**Radiolucent Body**  
May aid in surgeon visualization during fracture reduction and distraction

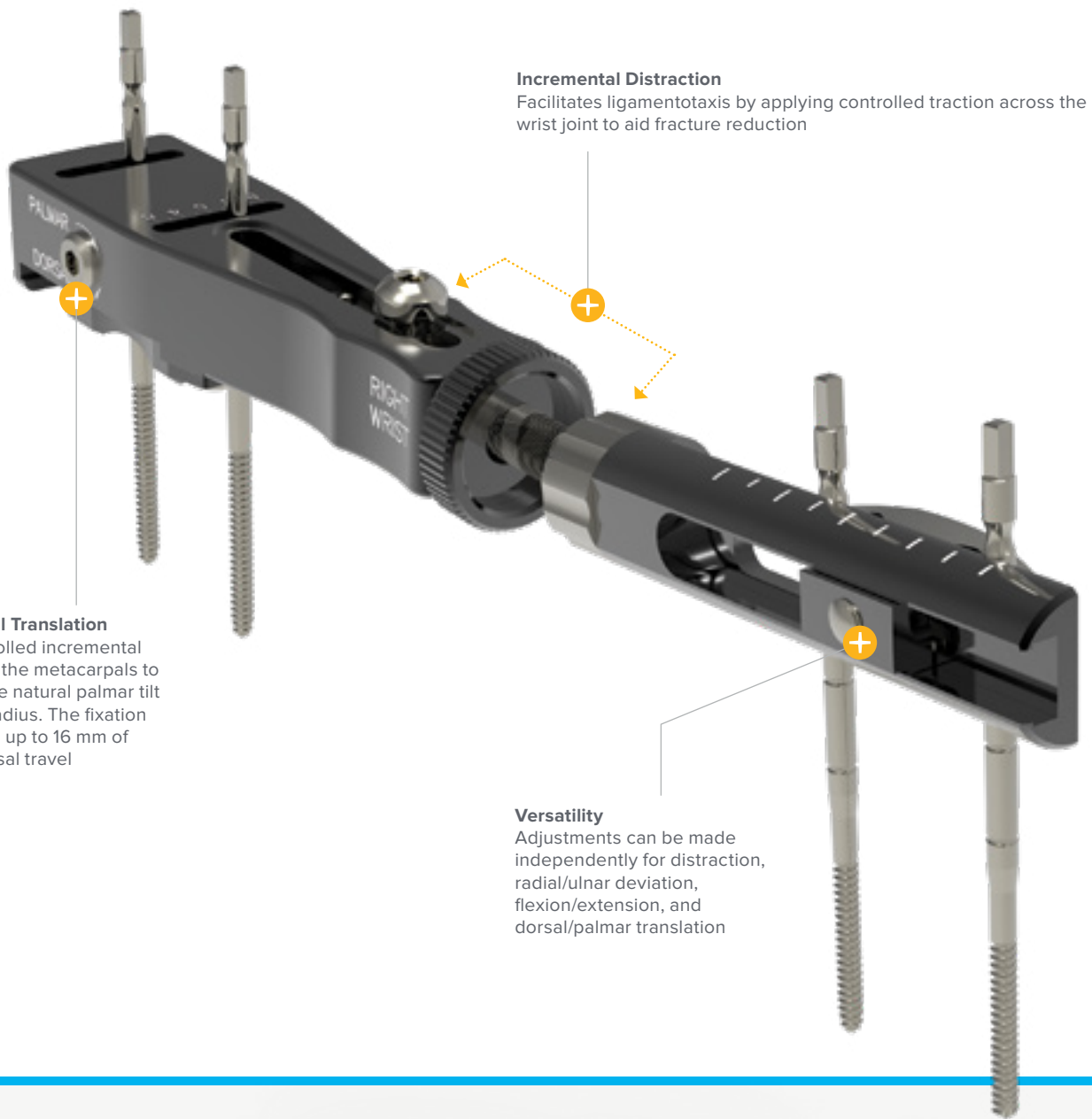

**Incremental Distraction**

Facilitates ligamentotaxis by applying controlled traction across the wrist joint to aid fracture reduction

**Palmar/Dorsal Translation**

Applies controlled incremental force through the metacarpals to reestablish the natural palmar tilt of the distal radius. The fixation system allows up to 16 mm of palmar or dorsal travel

**Versatility**

Adjustments can be made independently for distraction, radial/ulnar deviation, flexion/extension, and dorsal/palmar translation



2.7 and 3.2 mm pins  
(Optional, sterile-packed only)

Stableloc External Fixation System

## Small Joint Reamer System

The Acumed Small Joint Reamer System can be used in both the upper and lower extremities. The reamers are designed to create stable, congruent bone surfaces in the MTP, MCP, IP, and DIP joints prior to fusion procedures with Acumed plates, Acutrak 2® screws, or other methods of fixation.

Small Joint Reamers	Diameter
Concave Reamer	10 mm
Concave Reamer	12 mm
Concave Reamer	14 mm
Concave Reamer	16 mm
Concave Reamer	20 mm
Concave Reamer	24 mm
Convex Reamer	10 mm
Convex Reamer	12 mm
Convex Reamer	14 mm
Convex Reamer	16 mm
Convex Reamer	20 mm
Convex Reamer	24 mm



### Potential Upper Extremity Application

Fit phalanges together in desired flexion and fix with an MCP plate from the Acumed Modular Hand System or with an Acutrak 2 screw for DIP fusions



### Potential Lower Extremity Application

Create desired fit for MTP fusions when paired with the MTP plates found in the Acumed Locking Forefoot/Midfoot Plating System



### Specialized Instrumentation

System includes Reamer Gauges to assist in determining sizing prior to reaming the bone surface



**Cannulated Body**  
Cannulation accepts a  
.059" guide wire to facilitate  
reaming of bone surface

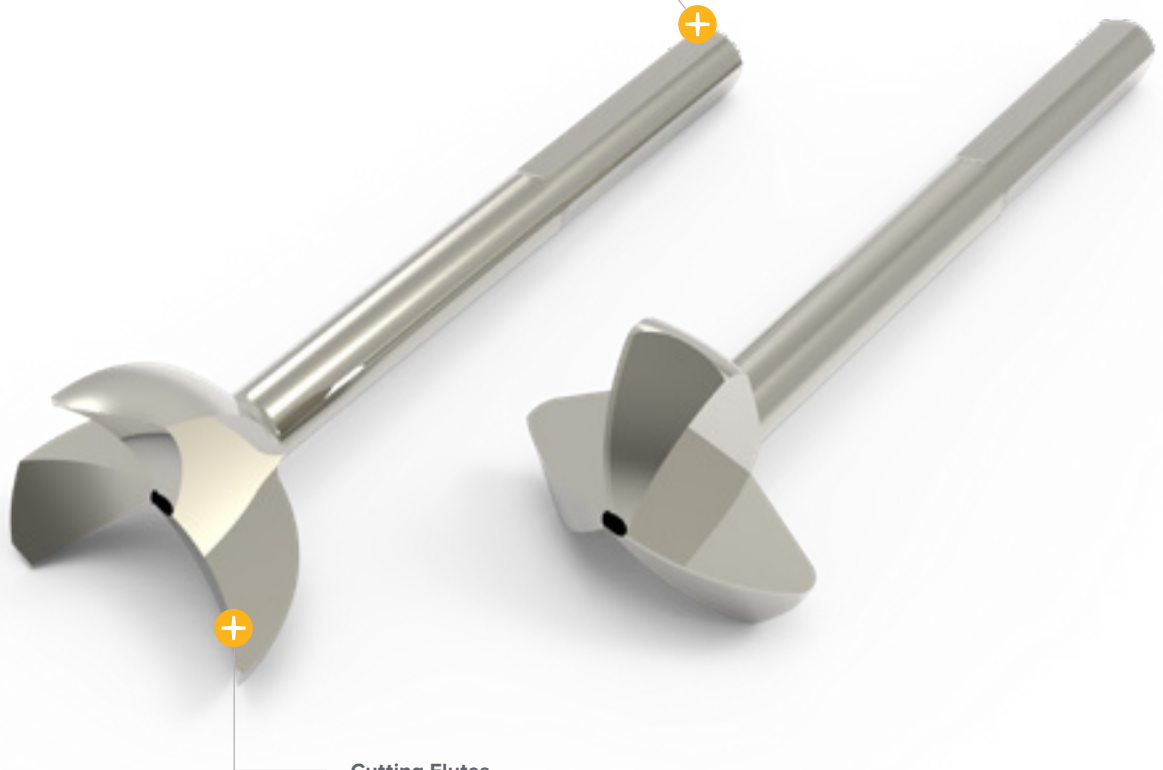

**Cutting Flutes**  
Designed to clear bone  
debris during use

Reamers are available in 10 mm, 12 mm, 14 mm, and 16 mm sizes for the fingers and thumb, and 20 mm and 24 mm sizes for the great toe



Concave Reamers

Convex Reamers

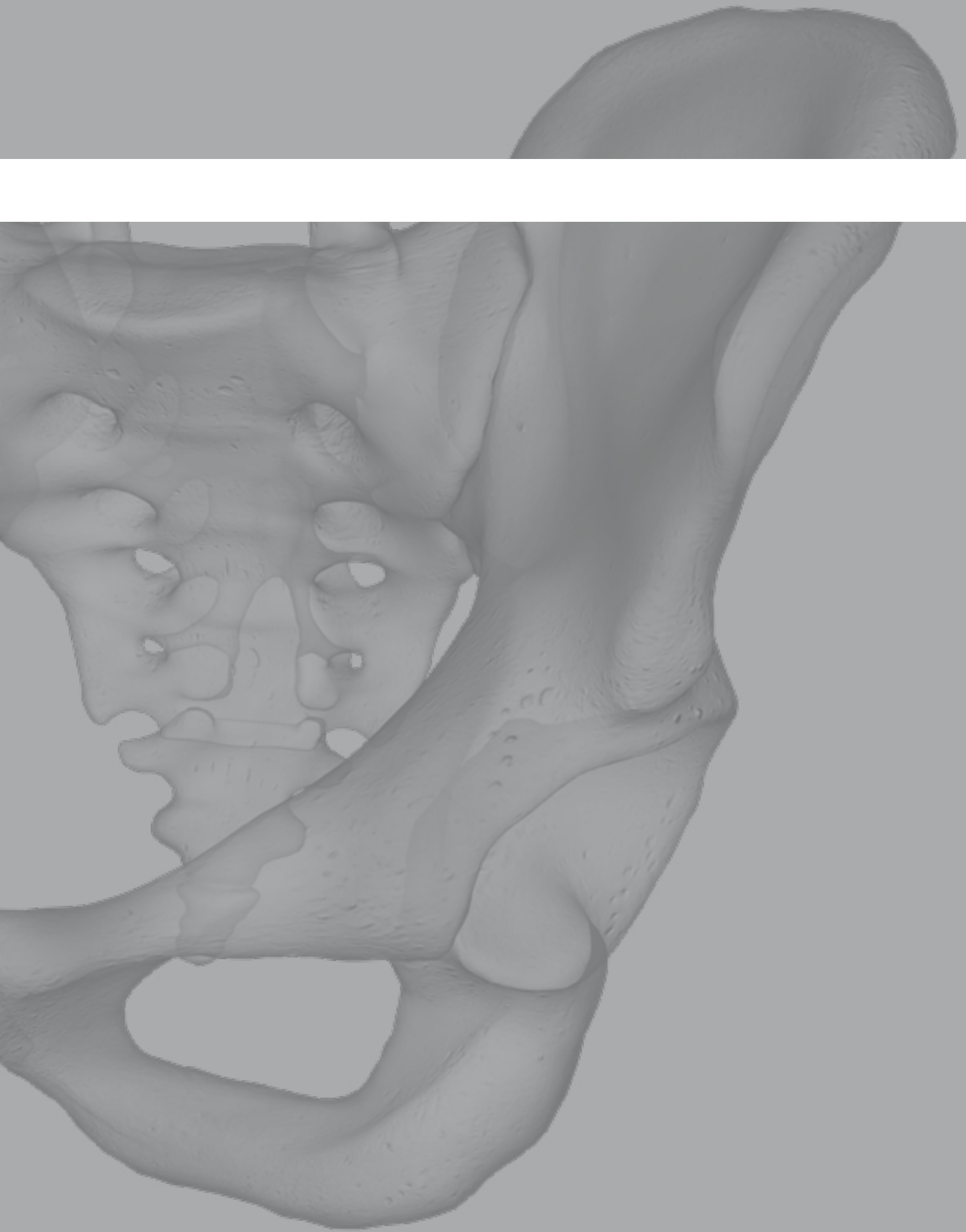

## Hip & Pelvis Product Lineup

Pelvic Plating System .....116

## Pelvic Plating System

The Acumed Pelvic Plating System is a comprehensive set of plates, screws, and instrumentation designed for fractures, fusions, and osteotomies of the acetabulum, sacrum, ilium, and pelvic ring. The system can also be used for sacroiliac joint dislocations and pubic symphysis disruptions. The implants are strategically precontoured where it may save time for the surgeon and left uncountoured where patient anatomy may require personal contouring.

Acetabular Plates	Hole Count	Thickness
Curved Posterior Wall Acetabular Frag Plate, Left, Right	11-hole	3.18 mm
Posterior Wall Acetabular Frag Plate, Left, Right	9-hole	3.18 mm
Posterior Wall Acetabular Plate	8-hole	3.18 mm
Acetabular Spring Plate	2 and 3-hole	1.65 mm

Pelvic Plates	Hole Count	Thickness
Superior Sacroiliac Plate	4-hole	3.30 mm
Quadrilateral Surface Plate, Left, Right	3-hole	1.52 mm
Pubic Symphysis Plate	4 and 6-hole	3.81 mm
Anterior Brim Plate, Left, Right	12 and 14-hole	3.18 mm
Intrapelvic Plate, Left, Right	5 and 9-hole	3.18 mm
3.5 mm Reconstruction Plate	3, 4, 6, 8, 10, 12, 14, and 16-hole	3.18 mm
3.5 mm Interlocking Reconstruction Plate	11-hole	3.18 mm



### Capturing Acetabular Wall Fractures

The Curved Posterior Wall Acetabular Fragment Plate features prongs along the center of the plate spread out to capture comminuted fractures of the acetabular wall, while the proximal end curves around the acetabular cup.

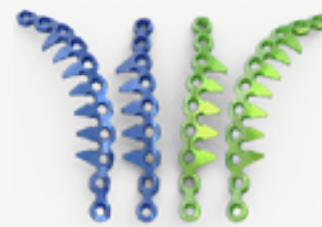
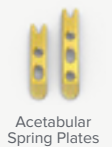
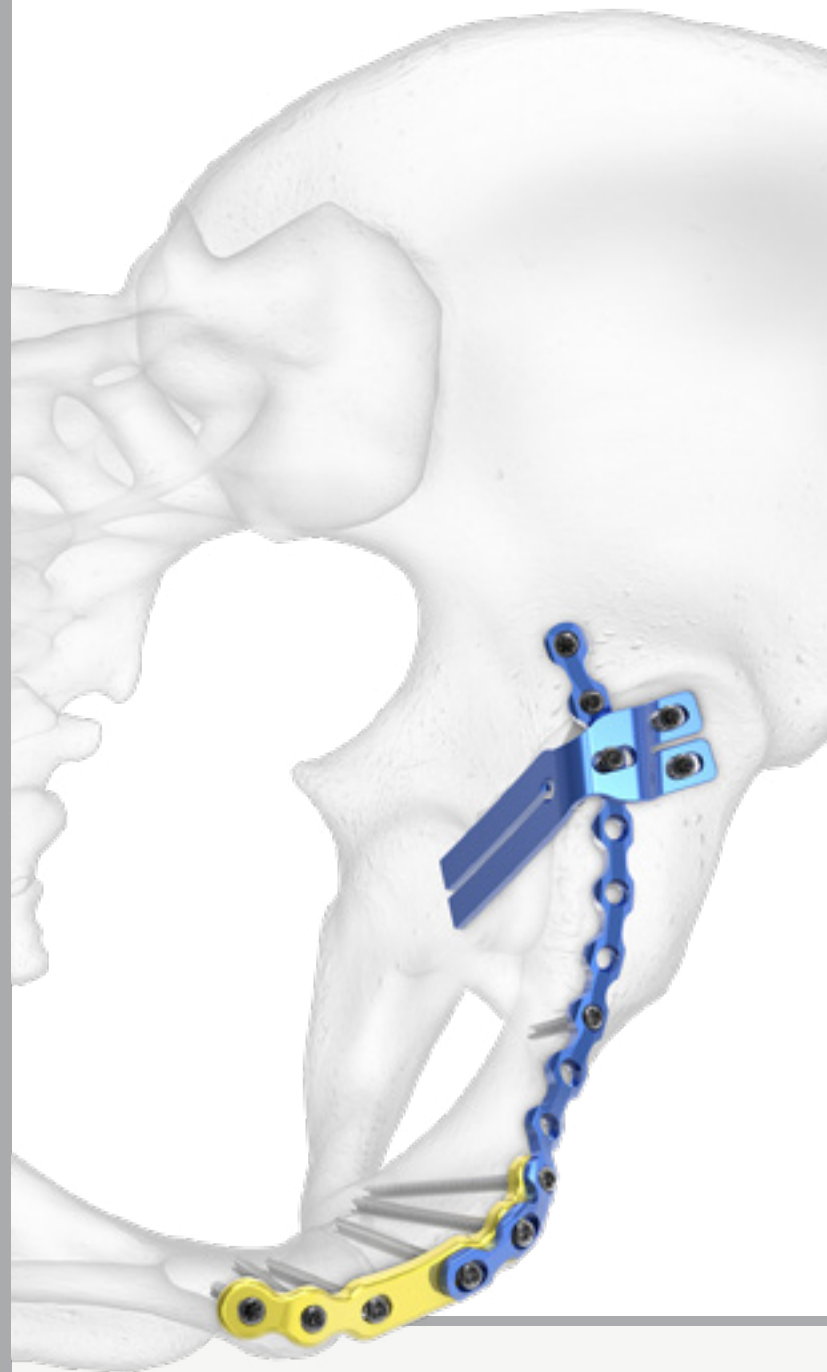

**Anterior Brim Plate**

Slots and holes on the anterior end of the plate are designed to interface with the Pubic Symphysis Plate, if desired

**3.5 mm Interlocking Reconstruction Plate**

To treat a wide variety of pelvic fractures, the 3.5 mm Interlocking Reconstruction Plate is designed to overlay other plates in the Pelvic Plating System



**Quadrilateral Surface Plate**

Designed to buttress the acetabulum's medial wall, the plate has tabs that are intended to offer two points of contact on the medial wall and add stability to the fragment

**Posterior Wall Acetabular Fragment Plate**

This curved plate features a precontoured distal end, designed to match the anatomy of the ischial tuberosity. Proximal screw placement is intended to optimize bone purchase while avoiding the acetabular joint

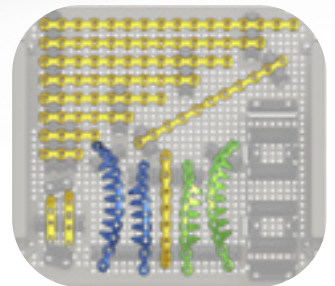

Superior Sacroiliac Plate

Quadrilateral Surface Plates

Pubic Symphysis Plates

Anterior Brim Plates

Intrapelvic Plates

3.5 mm Reconstruction Plates

3.5 mm Interlocking Reconstruction Plate



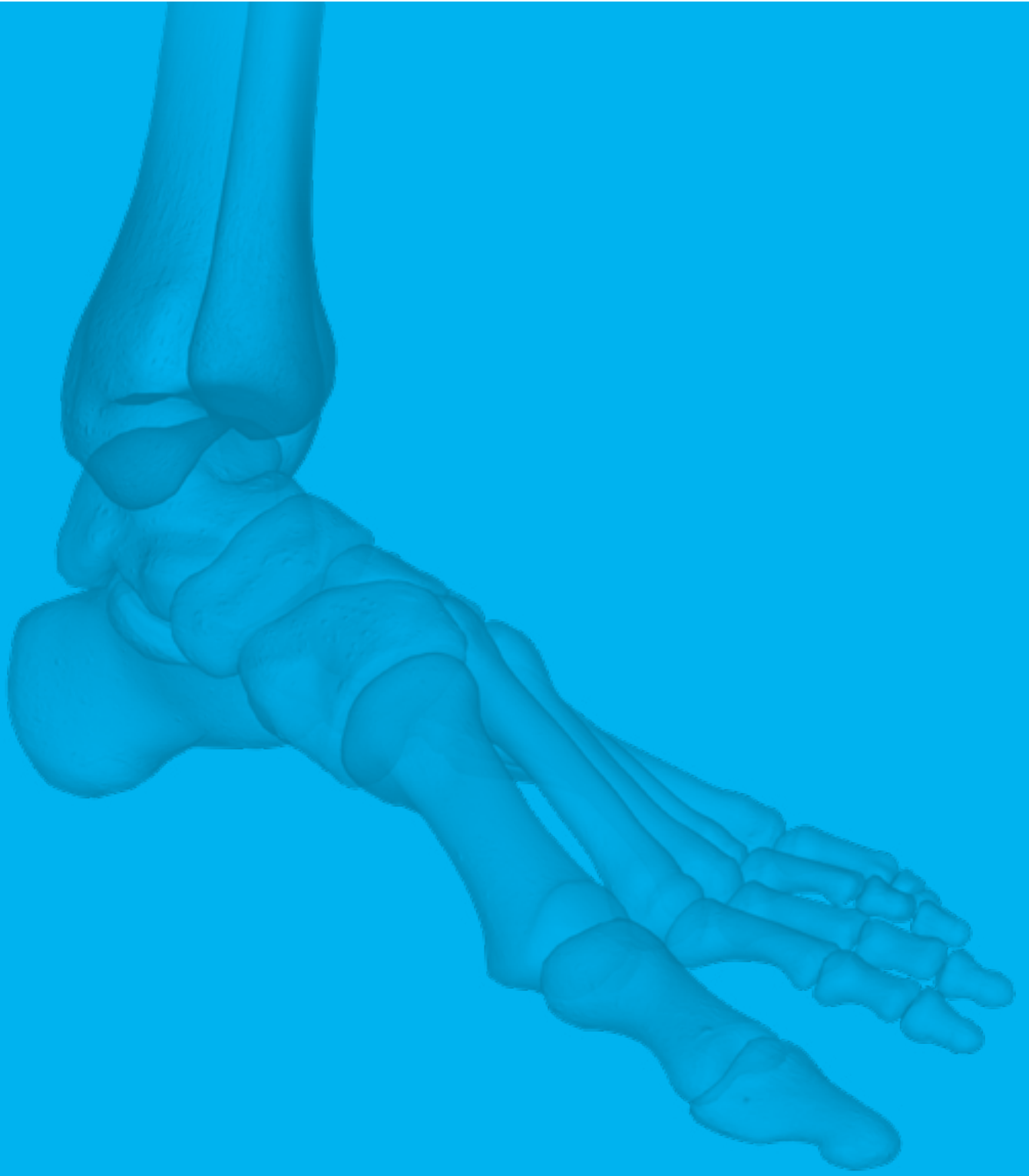

## Foot & Ankle Product Lineup

Ankle Plating System 3 .....	120
Small Fragment Base Set .....	122
ExtremiLock™ Ankle Plating System .....	124
Locking Ankle Plating System .....	126
Fibula Nail 2 System.....	128
Fibula Rod System .....	130
ExtremiLock™ Ankle Fusion Plating System .....	132
ExtremiLock™ Foot Plating System .....	134
FPS™ Foot Plating System .....	136
Forefoot/Midfoot Plating System .....	138
Calcaneal Plating System .....	140
Lower Extremity Modular System.....	142
Small Joint Reamer System.....	144
Talar-Fit™ Subtalar Arthroereisis Implant.....	146
EnCompass™ Metatarsal Resurfacing Implant .....	148
Hemi™ Great Toe Implant .....	150
ReFlexion™ 1 <sup>st</sup> MTP Implant System .....	152
ExtremiFuse™ Hammertoe Fixation System .....	154
InterPhlex™ Flexible Stabilization Rods .....	156
Calc-Jak .....	158

**Posterior Malleolus Plates**

The system features unique Posterolateral and Posteromedial Distal Tibia Plates for the fixation of challenging posterior malleolus fractures



**Cannulated Screws**

Three 4.0 Cannulated Screws are included for the treatment of medial malleolus fractures



**Two Styles of Hook Plates**

A hook plate with two distal prongs and a hook plate with a cortical peg are designed to address avulsion fractures of the distal tibia and fibula

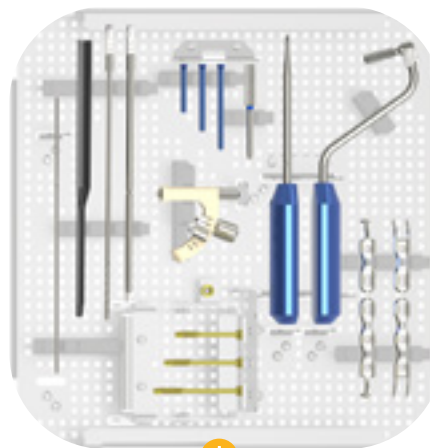

System-specific instrumentation in the ankle platter works in conjunction with the Small Fragment Base Set



Seven plate families address fractures of the medial, lateral, and posterior malleoli

Lateral Fibula Plates



Posterolateral Fibula Plates

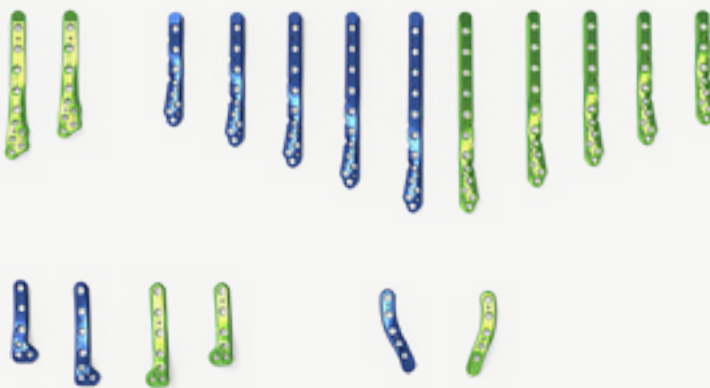

Posterolateral Distal Tibia Plates

Posteromedial Distal Tibia Plates



The industry's first fragment-specific Posterior Distal Tibia Plates launched in 2015.

## Ankle Plating System 3

The Ankle Plating System 3 offers precontoured plates and one-third tubular plates, located in the Acumed Small Fragment Base Set, for fractures of the distal tibia and fibula.



Acumed Small Fragment Base Set Required



Variable Angle Screw Compatibility Indicator



Lateral Fibula Plates	Hole Count	Length
Lateral Fibula Plate, Left & Right	4-hole	74 mm
Lateral Fibula Plate, Left & Right	5-hole	86 mm
Lateral Fibula Plate, Left & Right	6-hole	103 mm
Lateral Fibula Plate, Left & Right	7-hole	115 mm
Lateral Fibula Plate, Left & Right	9-hole	135 mm
<b>Opt*</b> Lateral Fibula Plate, Left & Right	11-hole	164 mm
<b>Opt*</b> Lateral Fibula Plate, Left & Right	13-hole	188 mm

Posterolateral Fibula Plates	Hole Count	Length
Posterolateral Fibula Plate, Left & Right	3-hole	66 mm
Posterolateral Fibula Plate, Left & Right	4-hole	78 mm
Posterolateral Fibula Plate, Left & Right	5-hole	90 mm
Posterolateral Fibula Plate, Left & Right	6-hole	102 mm
Posterolateral Fibula Plate, Left & Right	7-hole	116 mm

Posterolateral Distal Tibia Plates	Hole Count	Length
Posterolateral Distal Tibia Plate, Left & Right	3-hole	48 mm
Posterolateral Distal Tibia Plate, Left & Right	4-hole	60 mm

Posteromedial Distal Tibia Plates	Hole Count	Length
Posteromedial Distal Tibia Plate, Left & Right	3-hole	49 mm

Hook Plates	Hole Count	Length
Hook Plate	2-hole	43 mm
Hook Plate	3-hole	57 mm

Locking Peg Hook Plates	Hole Count	Length
Locking Peg Hook Plate	2-hole	45 mm
Locking Peg Hook Plate	3-hole	59 mm

Medial Anti-Glide Plate	Hole Count	Length
Medial Anti-Glide Plate	4-hole	70 mm

Cannulated Screws	Length
4.0 Cannulated Screw, Long Thread	36 mm
4.0 Cannulated Screw, Long Thread	42 mm
4.0 Cannulated Screw, Long Thread	48 mm

\*Opt: Optional, sterile-packed only

### Innovative Instrumentation

The Syndesmosis Targeting Guide attaches to the Posterolateral Fibula Plates and allows the surgeon to target the desired angle for syndesmosis screw fixation

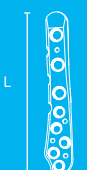

Hook Plates & Locking Peg Hook Plates

Medial Anti-Glide Plate



4.0 mm Cannulated Screws

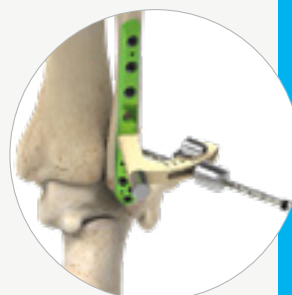

## Small Fragment Base Set

The Acumed Small Fragment Base Set is a comprehensive system for small-fragment trauma surgeries of the upper and lower extremities. The set is designed as both a stand-alone system with traditional plating and a complement to Acumed's precontoured plating systems. It includes straightforward instrumentation.



Acumed System  
Compatibility Indicator



Variable Angle Screw  
Compatibility Indicator

One-Third Tubular Plates	Hole Count	Length
One-Third Tubular Plate	3-hole	37 mm
One-Third Tubular Plate	4-hole	49 mm
One-Third Tubular Plate	5-hole	61 mm
One-Third Tubular Plate	6-Hole	73 mm
One-Third Tubular Plate	7-hole	85 mm
One-Third Tubular Plate	8-hole	97 mm
One-Third Tubular Plate	10-hole	121 mm
One-Third Tubular Plate	12-hole	145 mm

2.7 mm Fragment Plates	Length
Fragment Plate 2.7 mm	60 mm
L Fragment Plate 2.7 mm, Left	61 mm
L Fragment Plate 2.7 mm, Right	61 mm
T Fragment Plate 2.7 mm	61 mm

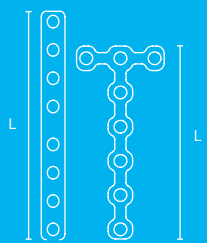

**Also Included**  
Acumed AcuTwist®  
Acutrak® Compression  
Screws and Tension  
Band Pins

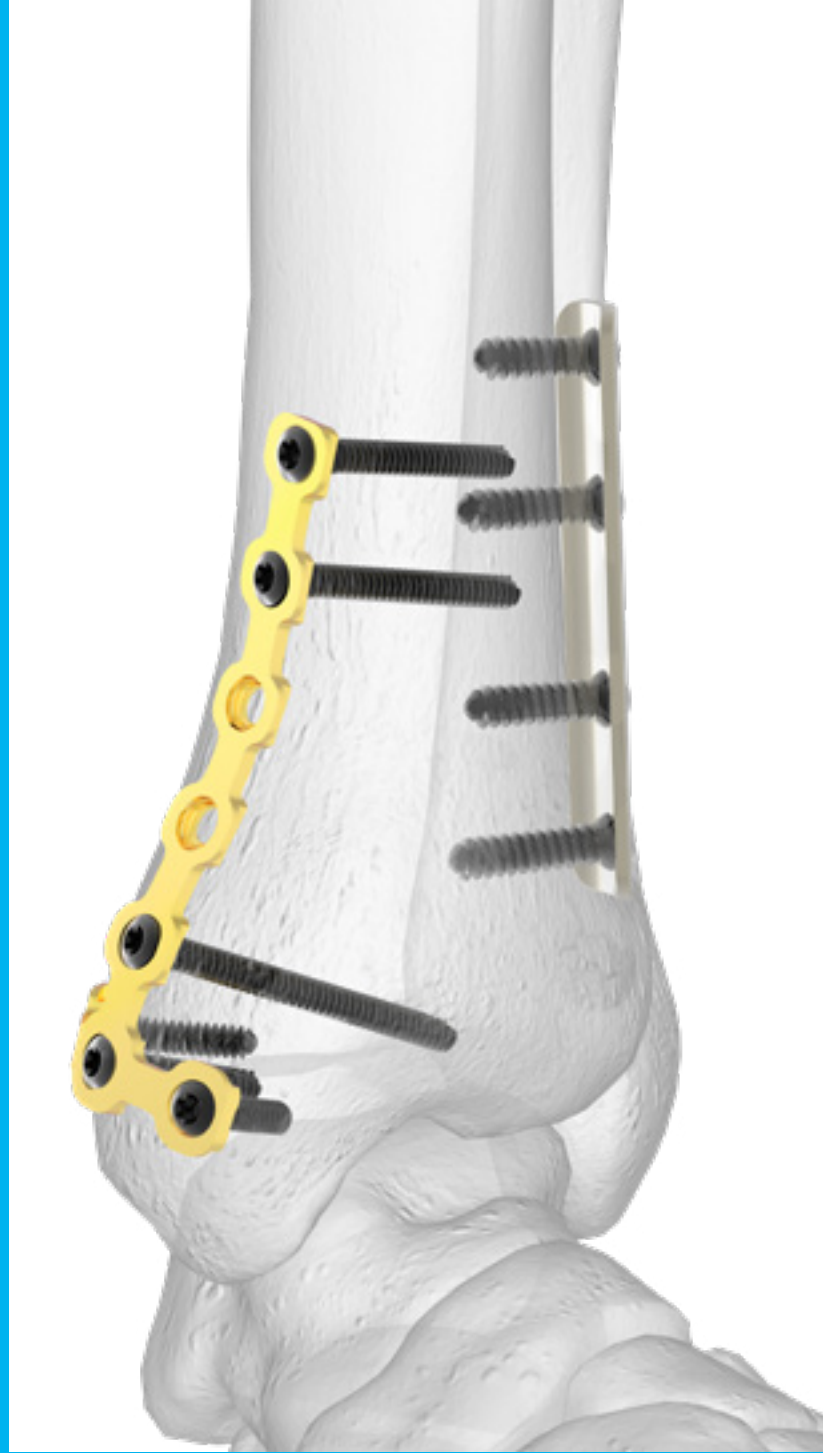
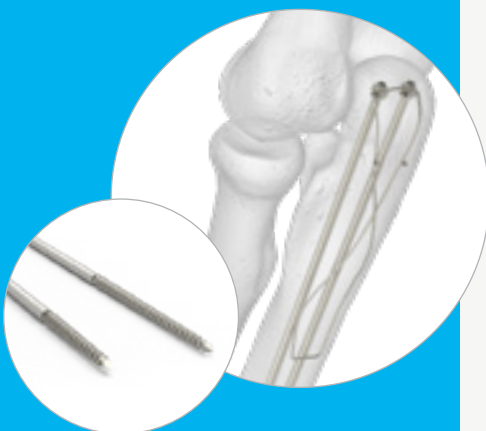

4.0 mm Fully and Partially Threaded  
Cancellous Hexalobe Screws



2.7 mm and 3.5 mm  
Locking Hexalobe Screws



2.7 mm and 3.5 mm  
Nonlocking Hexalobe Screws

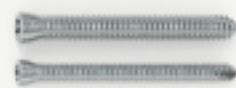

2.7 mm and 3.5 mm  
Variable Angle Hexalobe Screws



**One-Third Tubular Plates**  
 Plates are compatible with 3.5 mm Nonlocking Hexalobe Screws and are designed to minimize soft-tissue irritation



**Variable Angle Screws**  
 2.7 mm and 3.5 mm Variable Angle Hexalobe Screws are designed to lock up to 15 degrees off axis in any direction

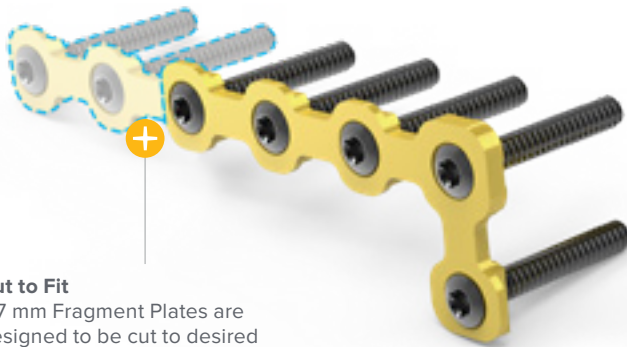

**Cut to Fit**  
 2.7 mm Fragment Plates are designed to be cut to desired length and bent prior to insertion or *in situ*

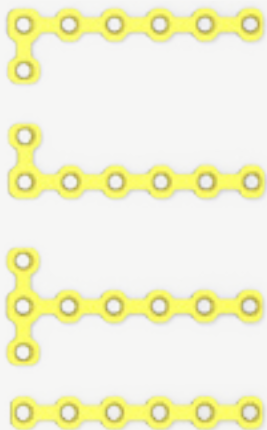
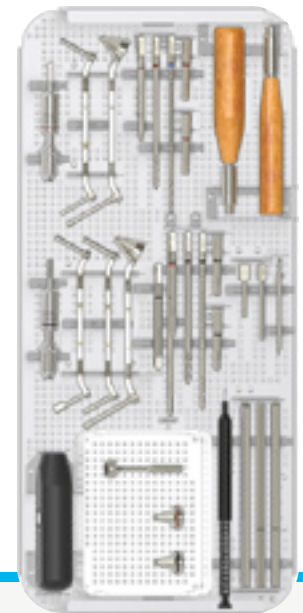

2.7 mm Fragment Plates

One-Third Tubular Plates

**Universal Screw Holes**

Circular plate holes accommodate 2.7, 3.5, and 4.0 mm locking, nonlocking, and variable angle screws

**Plate and Screw Options**

Seven plate types and seven screw options to accommodate surgical variation



**Anatomic Plate Designs**

Designed to match the contour of the bony anatomy, with soft, rounded edges and a highly smooth surface to minimize soft-tissue irritation

**Single-Lead Screws**  
1.25 mm per turn

**Double-Lead Screws**  
2.50 mm per turn



**Double-Lead Screw Technology**

Double-lead thread pattern provides faster screw insertion compared to single-lead screws



Anterior Lateral Plates

Anterior Tibia Plate

Lateral Tibia Plates

Universal Hook Plate

## ExtremiLock™ Ankle Plating System

The OsteoMed ExtremiLock Ankle Plating System provides options for fixation of fractures of the tibia and fibula all in one comprehensive system. An Ankle Fusion Plating module is included to address ankle fusion management. The system has seven plate families and seven screw types designed to treat both low- and high-energy ankle fractures.

Lateral Fibula Plates	Holes	Length	Thickness
Lateral Fibula Plate, Left & Right	3-Hole	85 mm	1.4 mm
Lateral Fibula Plate, Left & Right	6-Hole	115 mm	1.4 mm
Lateral Fibula Plate, Left & Right	9-Hole	145 mm	1.4 mm

\*Additional Plates, Left & Right: (2H, 75 mm, 1.4 mm), (4H, 95 mm, 1.4 mm), (5H, 105 mm, 1.4 mm), (7H, 125 mm, 1.4 mm), (8H, 135 mm, 1.4 mm), (10H, 155 mm, 1.4 mm), (11H, 165 mm, 1.4 mm), (12H, 175 mm, 1.4 mm), (13H, 185 mm, 1.4 mm), (14H, 195 mm, 1.4 mm)

Anterior Lateral Plates	Holes	Length	Thickness
Anterior Lateral Plate, Left & Right	7-Hole	80 mm	1.4 mm
Anterior Lateral Plate, Left & Right	10-Hole	111 mm	1.4 mm
Anterior Lateral Plate, Left & Right	13-Hole	143 mm	1.4 mm

\*Additional Plates, Left & Right: (15H, 164 mm, 1.4 mm), (17H, 184 mm, 1.4 mm), (19H, 206 mm, 1.4 mm), (21H, 226 mm, 1.4 mm), (23H, 247 mm, 1.4 mm), (25H, 267 mm, 1.4 mm), (27H, 289 mm, 1.4 mm)

Anterior Tibia Plate	Holes	Length	Thickness
*Anterior Tibia Plate, Universal	3-Hole	62 mm	1.4 mm
Anterior Tibia Plate, Universal	6-Hole	92 mm	1.4 mm

Medial Tibia Plates	Holes	Length	Thickness
Medial Tibia Plate	4-Hole	89 mm	1.5 mm
Medial Tibia Plate	6-Hole	109 mm	1.5 mm

\*Additional Plates: (2H, 69 mm, 1.5 mm), (8H, 129 mm, 1.5 mm), (10H, 149 mm, 1.5 mm), (12H, 169 mm, 1.5 mm)

Universal Hook Plate	Holes	Length	Thickness
*Hook Plate, Universal	5-Hole	58 mm	2 mm
Hook Plate, Universal	7-Hole	81 mm	2 mm

One-Third Tubular Plate	Holes	Length	Thickness
One-Third Tubular Plate	4-Hole	40 mm	1.4 mm
One-Third Tubular Plate	6-Hole	60 mm	1.4 mm
One-Third Tubular Plate	8-Hole	80 mm	1.4 mm

\*Additional Plates: (2H, 20 mm, 1.4 mm), (3H, 30 mm, 1.4 mm), (5H, 50 mm, 1.4 mm), (7H, 70 mm, 1.4 mm), (9H, 90 mm, 1.4 mm), (10H, 100 mm, 1.4 mm), (11H, 110 mm, 1.4 mm), (12H, 120 mm, 1.4 mm), (13H, 130 mm, 1.4 mm), (14H, 140 mm, 1.4 mm)

*Distal Fibula Plates	Holes	Length	Thickness
-----------------------	-------	--------	-----------

Distal Fibula Plates, Left & Right:

(2H, 47 mm, 1.6 mm), (3H, 59 mm, 1.6 mm), (4H, 71 mm, 1.6 mm), (5H, 83 mm, 1.6 mm), (6H, 95 mm, 1.6 mm), (7H, 107 mm, 1.6 mm), (8H, 119 mm, 1.6 mm), (9H, 131 mm, 1.6 mm), (10H, 143 mm, 1.6 mm), (11H, 155 mm, 1.6 mm), (12H, 167 mm, 1.6 mm), (13H, 179 mm, 1.6 mm), (14H, 191 mm, 1.6 mm)

\*Optional, sterile-packed only. Please see the ExtremiLock™ Ankle Plating System Surgical Technique Guide (030-2231 and 030-1953) for full ordering information.



1/3 Tubular Plates



Medial Tibia Plates



Distal Fibula Plate

## Locking Ankle Plating System

The Locking Ankle Plating System features plates for fractures of the distal tibia and fibula. Plates are designed to offer internal fixation for fractures, fusions, and osteotomies of the lateral fibula, anterior tibia, and medial tibia. This system was designed to be low profile, and includes locking screws and a Type II anodized plate finish.

Lateral Fibula Plates	Hole Count	Length
Lateral Fibula Plate	9-hole	93 mm
Lateral Fibula Plate	11-hole	121 mm
Lateral Fibula Plate	13-hole	146 mm

Low-profile Locking (LPL) Lateral Fibula Plates	Hole Count	Length
LPL Lateral Fibula Plate	5-hole	61 mm
LPL Lateral Fibula Plate	7-hole	85 mm
LPL Lateral Fibula Plate	9-hole	109 mm
LPL Lateral Fibula Plate	11-hole	133 mm
LPL Lateral Fibula Plate	13-hole	157 mm

LPL Anterior Tibia Plates	Hole Count	Length
LPL Anterior Tibia Plate	5-hole	60 mm
LPL Anterior Tibia Plate	7-hole	85 mm

LPL Medial Tibia Plates	Hole Count	Length
LPL Medial Tibia Plate	7-hole	82 mm
LPL Medial Tibia Plate	9-hole	106 mm

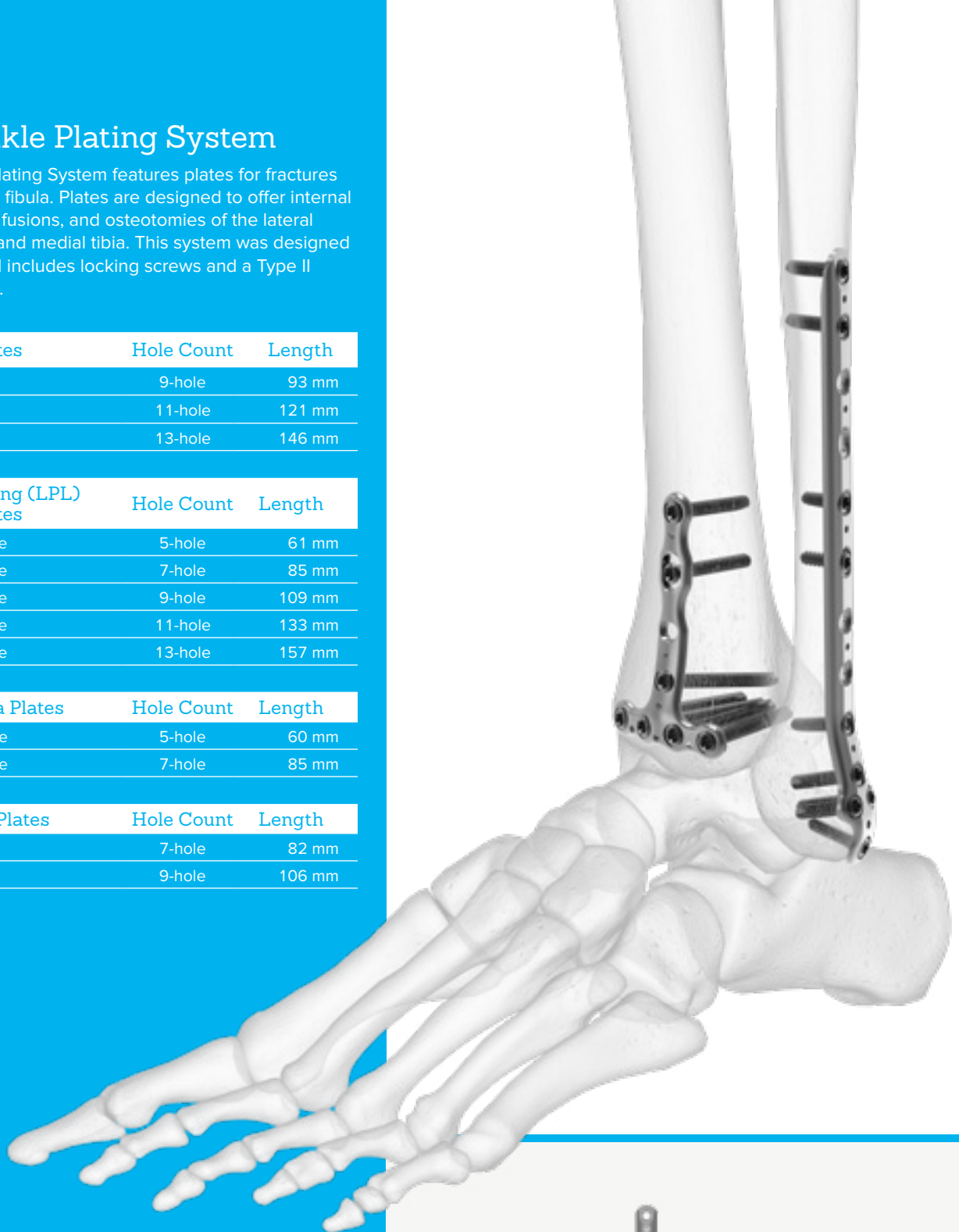
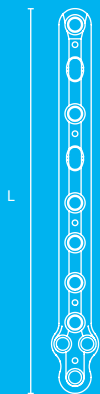

Lateral Fibula Plates

**Low-profile Geometry**

Plates with a low profile are engineered to minimize soft-tissue irritation

**Locking Technology**

Locking plates do not rely on plate-to-bone compression to obtain stability

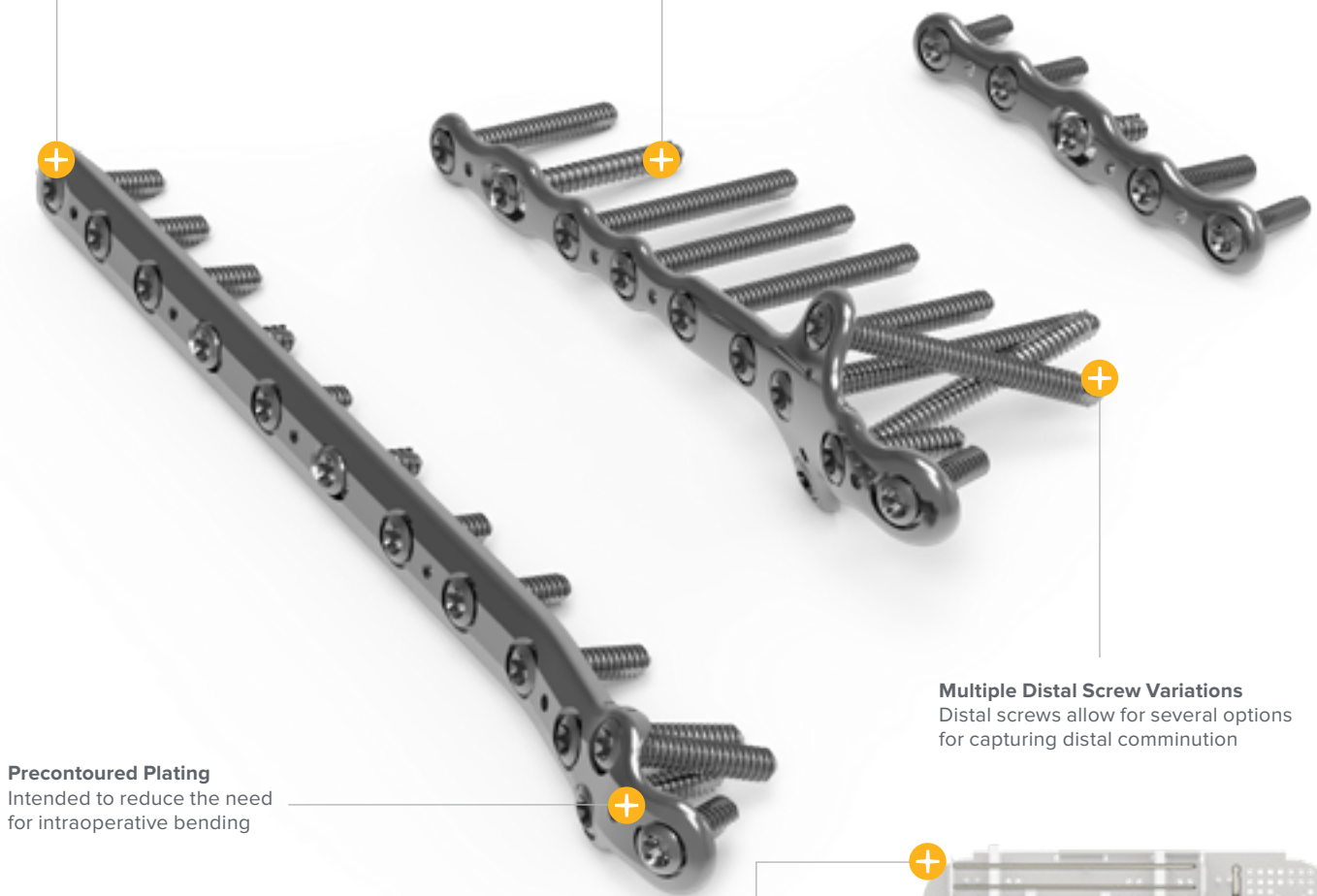

**Precontoured Plating**

Intended to reduce the need for intraoperative bending

**Multiple Distal Screw Variations**

Distal screws allow for several options for capturing distal comminution

The Locking Ankle Plating System is a modular component of the Lower Extremity Modular System, which houses a range of implants and instrumentation for foot and ankle applications

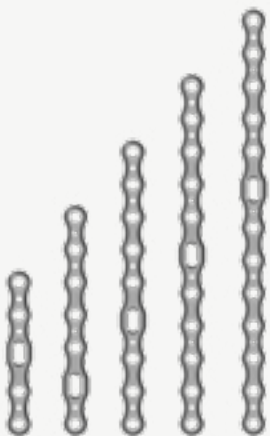

LPL Lateral Fibula Plates

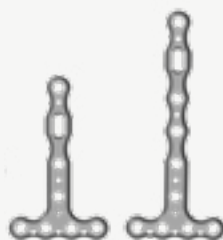

LPL Anterior Tibia Plates

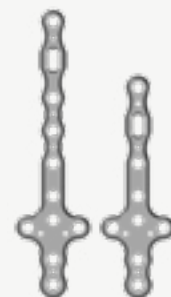

LPL Medial Tibia Plates



## Fibula Nail 2 System

Designed in conjunction with Roy Sanders, MD, the Fibula Nail 2 System addresses simple, transverse, and short oblique fractures and osteotomies of the fibula. It includes three nail diameters and four length options, power reamers, and carbon fiber radiolucent targeting guides to streamline the procedure. It must be used with the instrumentation and screws provided in the Acumed Fibula and Forearm Nail 2 Base Set.

Fibula Nail 2	Length	Tip Diameter
Fibula Nail 2	110 mm	2.6 mm
Fibula Nail 2	145 mm	2.6 mm
Fibula Nail 2	190 mm	2.6 mm
Fibula Nail 2	270 mm	2.6 mm
Fibula Nail 2	110 mm	3.0 mm
Fibula Nail 2	145 mm	3.0 mm
Fibula Nail 2	190 mm	3.0 mm
Fibula Nail 2	270 mm	3.0 mm
Fibula Nail 2	110 mm	3.6 mm
Fibula Nail 2	145 mm	3.6 mm
Fibula Nail 2	190 mm	3.6 mm
Fibula Nail 2	270 mm	3.6 mm



### Updated Instrumentation

System includes power reamers to optimize operative time and carbon fiber targeting guides that can only be assembled in the proper orientation to help streamline the procedure



### Optional End Caps

Offered in +0.4 mm, +5 mm, +10 mm, and +15 mm lengths and thread into the tail of the fibula nail. Assist in limiting ossification over the end of the nail, making the nail threads easier to engage if removal is desired, and allowing surgeons to create an intermediate nail length while adjusting for anatomic variances and screw trajectories

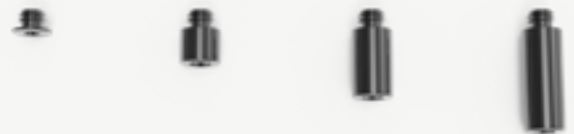

+0.4 mm End Cap    +5 mm End Cap    +10 mm End Cap    +15 mm End Cap

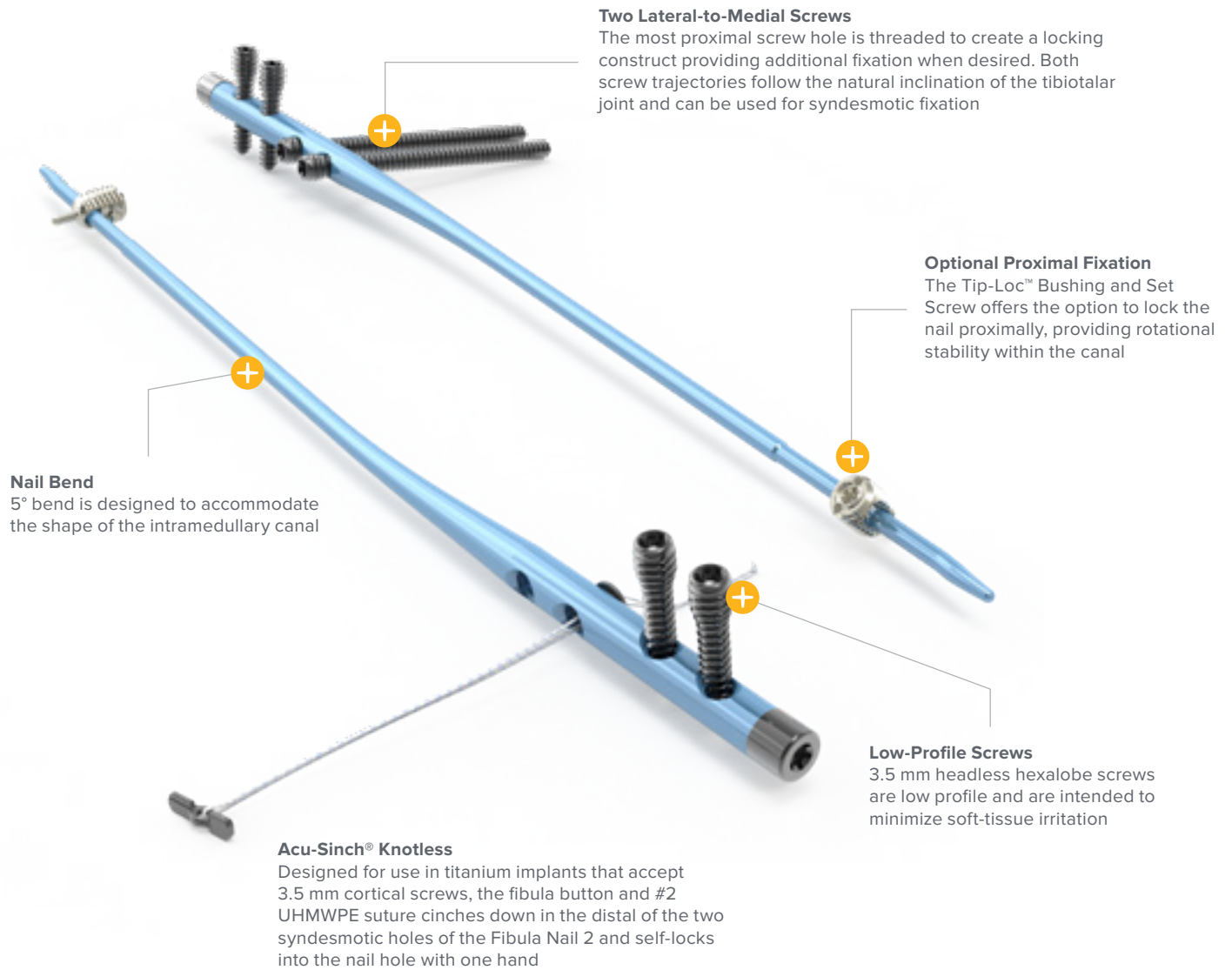

**Two Lateral-to-Medial Screws**  
 The most proximal screw hole is threaded to create a locking construct providing additional fixation when desired. Both screw trajectories follow the natural inclination of the tibiotalar joint and can be used for syndesmotic fixation

**Optional Proximal Fixation**  
 The Tip-Loc™ Bushing and Set Screw offers the option to lock the nail proximally, providing rotational stability within the canal

**Nail Bend**  
 5° bend is designed to accommodate the shape of the intramedullary canal

**Low-Profile Screws**  
 3.5 mm headless hexalobe screws are low profile and are intended to minimize soft-tissue irritation

**Acu-Sinch® Knotless**  
 Designed for use in titanium implants that accept 3.5 mm cortical screws, the fibula button and #2 UHMWPE suture cinches down in the distal of the two syndesmotic holes of the Fibula Nail 2 and self-locks into the nail hole with one hand



2.6 mm Fibula Nail 2



3.0 mm Fibula Nail 2



3.6 mm Fibula Nail 2

**Precontoured Bend Aligns With Fibular Canal**  
Rods have a 5° bend, designed to fit the intramedullary canal of the fibula

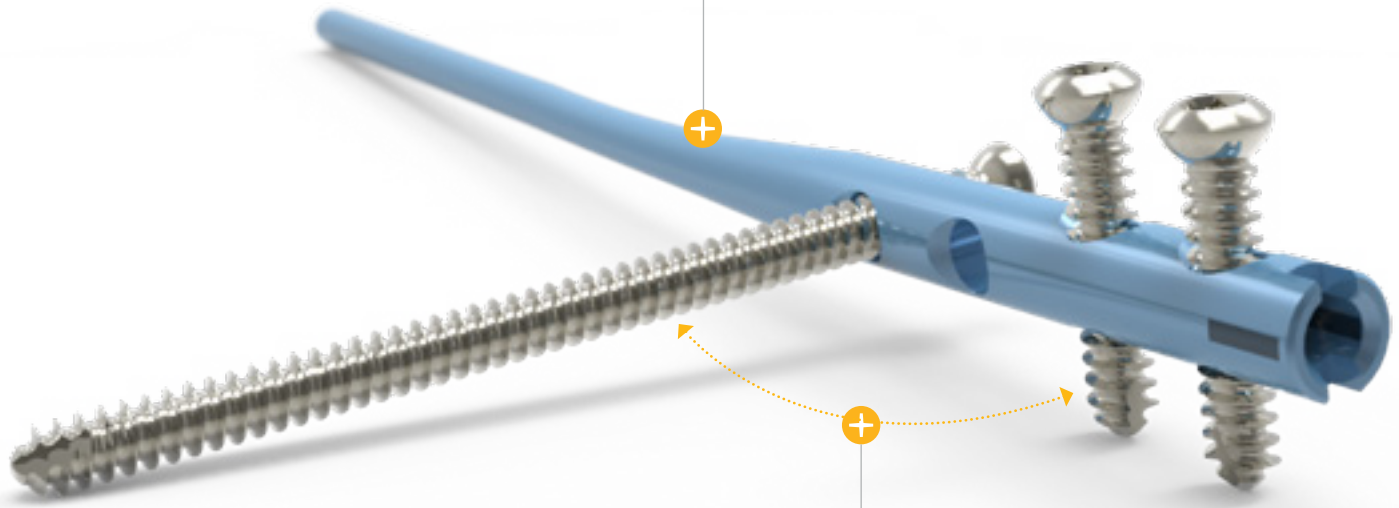

**A/P and M/L Screws**  
Screw directions designed to minimize longitudinal or rotational displacement while stabilizing the lateral buttress of the mortise



3.0 mm Tip Diameter



3.6 mm Tip Diameter

## Fibula Rod System

The Acumed Fibula Rod System offers an alternative approach to traditional fibular plating by providing fracture stability through a minimally invasive surgical procedure. Using a targeting guide, the fibula rod and interlocking screws can be inserted through small incisions, which may reduce total operating time compared to traditional open reduction internal fixation (ORIF).

Fibula Rods	Length	Tip Diameter
Fibula Rod	110 mm	3.0 mm
Fibula Rod	145 mm	3.0 mm
Fibula Rod	180 mm	3.0 mm
Fibula Rod	110 mm	3.6 mm
Fibula Rod	145 mm	3.6 mm
Fibula Rod	180 mm	3.6 mm

**Note:** Base diameter for all rods is 6 mm



### Fibula Rod Targeting Guide

Aids in the correct placement of both A/P and M/L screws and allows for syndesmotomic screw fixation



**Multiple Compression Options**

Oblong holes, transfixation holes, and an anatomic transfixation 5.5 mm lag screw compression hole, designed to cross the arthrodesis site within the plate

**Universal Screw Holes**

3.5 mm and 4.0 mm cortical locking and nonlocking screws available for patient-specific fixation

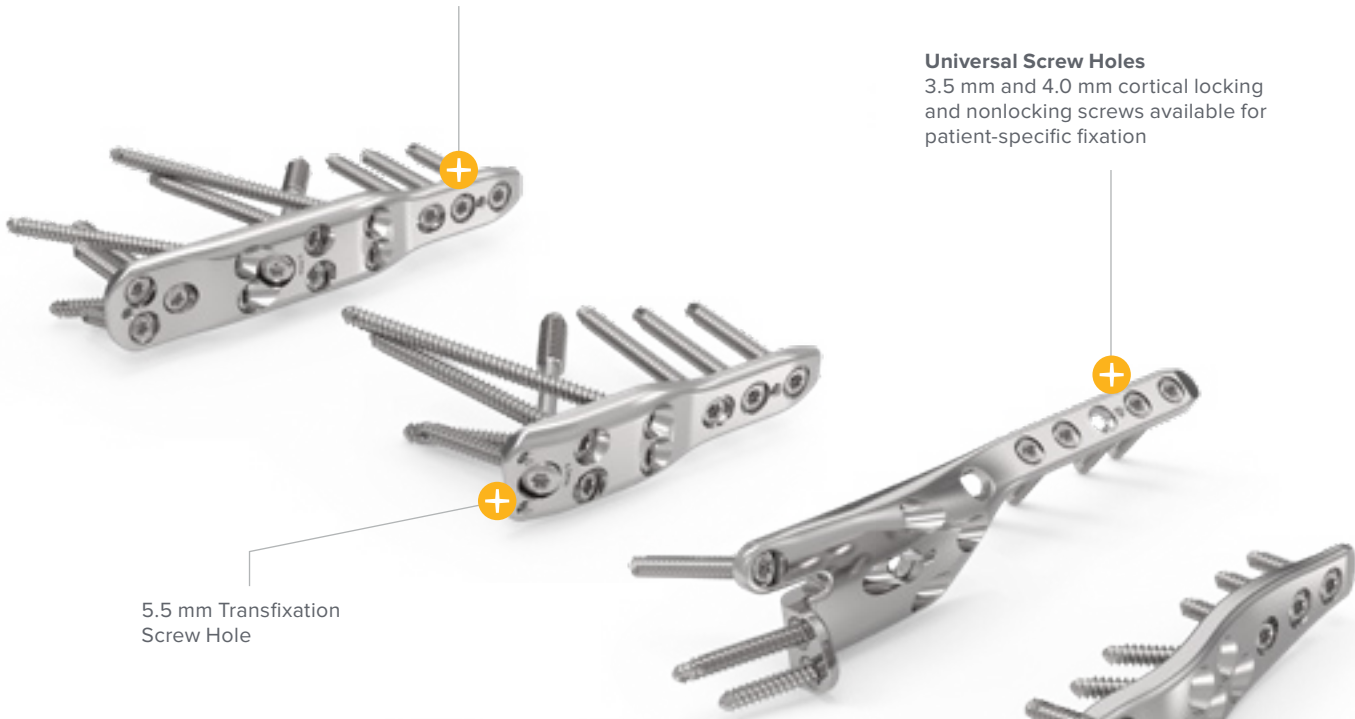

5.5 mm Transfixation Screw Hole

**Low Profile**

Tapered proximal tip and solid low-profile design eases percutaneous insertion and minimizes soft-tissue irritation



Ankle Fusion Plates are housed within the ExtremiLock™ Ankle Fusion Module, residing at the bottom of the ExtremiLock Ankle Plating System tray



Anterior Fusion Plates

Posterior Fusion Plates



## ExtremiLock™ Ankle Fusion Plating System

Offered as a module within the ExtremiLock Ankle Plating System, the ExtremiLock Ankle Fusion Plating System includes anatomically contoured anterior, posterior, and lateral fusion plates to address tibiotalar (TT) and tibiotalocalcaneal (TTC) arthrodesis. The universal holes of the plates accept a variety of screw diameters, including locking, nonlocking, and cannulated screw options designed to accommodate surgical variation and surgeon preference.

Anterior Fusion Plates	Holes	Length	Thickness
*Anterior Fusion, Left & Right	3-Hole	101.5 mm	6.5 mm
Anterior Fusion, Left & Right	5-Hole	121.5 mm	6.5 mm
*Anterior Fusion, Left & Right	7-Hole	141.5 mm	6.5 mm

Lateral Fusion Plates	Holes	Length	Thickness
Lateral Tibiotalar (TT) Fusion Plate		71 mm	5.1 mm
Lateral Tibiotalocalcaneal (TTC) Fusion Plate		101 mm	5.1 mm

Posterior Fusion Plates	Holes	Length	Thickness
Posterior Fusion, Universal	3-Hole	84 mm	5.1 mm
*Posterior Fusion, Universal	6-Hole	114 mm	5.1 mm

\*Optional, sterile-packed only.

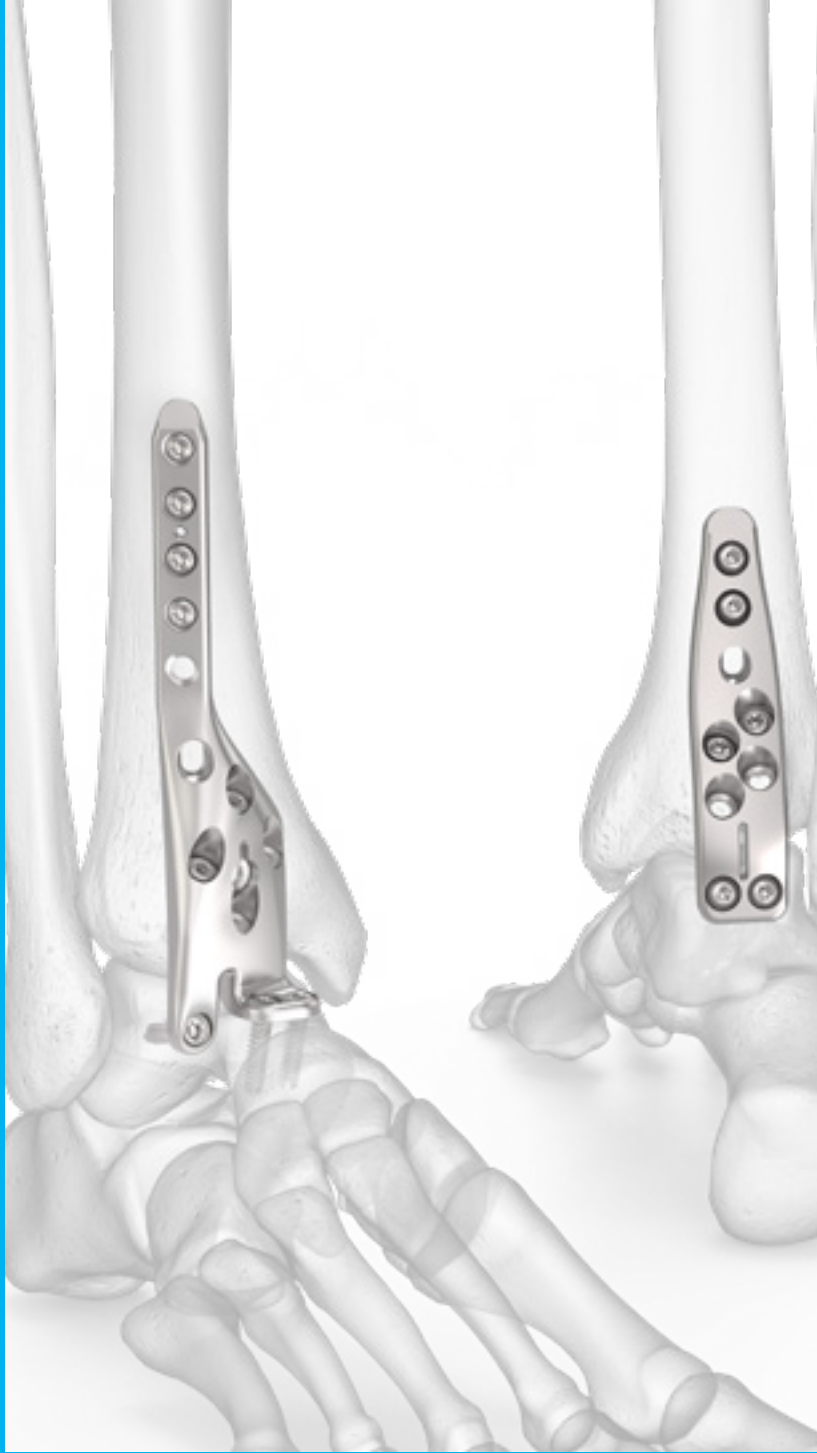

Lateral Tibiotalar (TT) Fusion Plates



Lateral Tibiotalocalcaneal (TTC) Fusion Plates

Single-Lead Screws  
1.25 mm per turn

Double-Lead Screws  
2.50 mm per turn

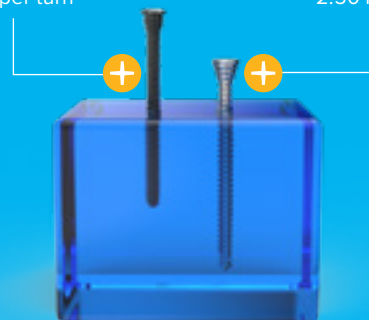

# ExtremiLock™ Foot Plating System

The OsteoMed ExtremiLock Foot Plating System includes the latest in variable angle locking screw and plate technology to treat multiple reconstructive and trauma applications of the forefoot, midfoot, and hindfoot. Dedicated instrumentation in this comprehensive system allows for multiple intraoperative options to accommodate surgical variation and patient anatomy.



Fracture/Fusion Plates	Length	Width	Thickness
------------------------	--------	-------	-----------

4-Hole Hook Plate	37.64 mm	7.87 mm	1.4 mm
6-Hole Hook Plate, Left & Right	54.6 mm	14.5 mm	1.4 mm
6-Hole T Compression Plate	39.9 mm	22.4 mm	1.2 mm
9-Hole Y Compression Plate	70.4 mm	21.5 mm	1.2 mm
10-Hole Subcondylar Plate	59.3 mm	13.3 mm	1.2 mm

Metatarsal Wedge Plates	Length	Width	Thickness
-------------------------	--------	-------	-----------

0 mm Wedge Plate		18.5 mm	1.2 mm
3–6 mm Wedge Plates	24 mm	17 mm	1.2 mm

1 <sup>st</sup> MTP Fusion Plates	Length	Width	Thickness
-----------------------------------	--------	-------	-----------

Fusion Plate, 10°, Left & Right	44.4 mm	13.3 mm	1.4 mm
Primary Plate, 6-Hole, 0°/5°, Left & Right	44.4 mm	14.88 mm	1.4 mm
Transfixation Plate, 10°, Left & Right	48.6 mm	14.84 mm	1.4 mm
5-Hole Narrow, 0°/5°, Left & Right	45.7 mm	14.9 mm	1.4 mm

Lapidus Plates	Length	Width	Thickness
----------------	--------	-------	-----------

0mm Step Plate (H-Plate)	30.5 mm	16.4 mm	1.4 mm
2–4 mm Step Plate	30.8 mm	17 mm	1.4 mm
2.7 mm Lapidus Plate	30.4 mm	16 mm	1.2 mm
3.5/4.0 mm Lapidus Plate	34.3 mm	18.8 mm	1.4 mm
3.5/4.0 mm Lapidus Plate, Dorsalmedial	38.3 mm	17.8 mm	1.4 mm

Midfoot/Hindfoot Plates	Length	Width	Thickness
-------------------------	--------	-------	-----------

15 mm H Plate	27.2 mm	18.4 mm	1.4 mm
20 mm H Plate	32.2 mm	18.4 mm	1.4 mm
30 mm H Plate	42.2 mm	18.3 mm	1.2 mm
6, 8, 10 mm Step Plates	27.6 mm	17.8 mm	2.0 mm
4 mm Wedge Plate	30 mm	20 mm	1.4 mm
6 mm Wedge Plate	32 mm	20 mm	1.4 mm
8 mm Wedge Plate	34 mm	20 mm	1.4 mm

Compression Plates	Length	Width	Thickness
--------------------	--------	-------	-----------

2-Hole Straight Plate, Short & Long	36, 44 mm	8.64 mm	1.4 mm
2-Hole Straight Plate, Short	25.4 mm	7.4 mm	1.2 mm
3-Hole Straight Plate, Long	44.9 mm	8.64 mm	1.4 mm
4-Hole Straight Plate	42.7 mm	7.4 mm	1.4 mm
5-Hole Straight Plate	39.9 mm	7.4 mm	1.2 mm

Medial Column Fusion Plates	Length	Width	Thickness
-----------------------------	--------	-------	-----------

Medial Column Plate, Short	47.6 mm	26.9 mm	1.4 mm
Medial Column Plate, Medium	72.4 mm	26.9 mm	1.4 mm
Medial Column Plate, Long	89.7 mm	26.9 mm	1.4 mm

Calcaneal Plates	Length	Width	Thickness
------------------	--------	-------	-----------

56 mm Calcaneal Mesh Plate	56 mm	34.4 mm	2.0 mm
65 mm Calcaneal Mesh Plate	65 mm	40 mm	2.0 mm
56 mm Calcaneal Plate Left & Right	58 mm	31 mm	1.4 mm
65 mm Calcaneal Plate Left & Right	65 mm	37 mm	1.4 mm



Wedge Plates

Step Plates



Calcaneal Plates

Calcaneal Mesh Plates

**Comprehensive Solution**

Offers numerous plating options in several specialized modules to treat multiple reconstructive and trauma applications for forefoot, midfoot, and hindfoot

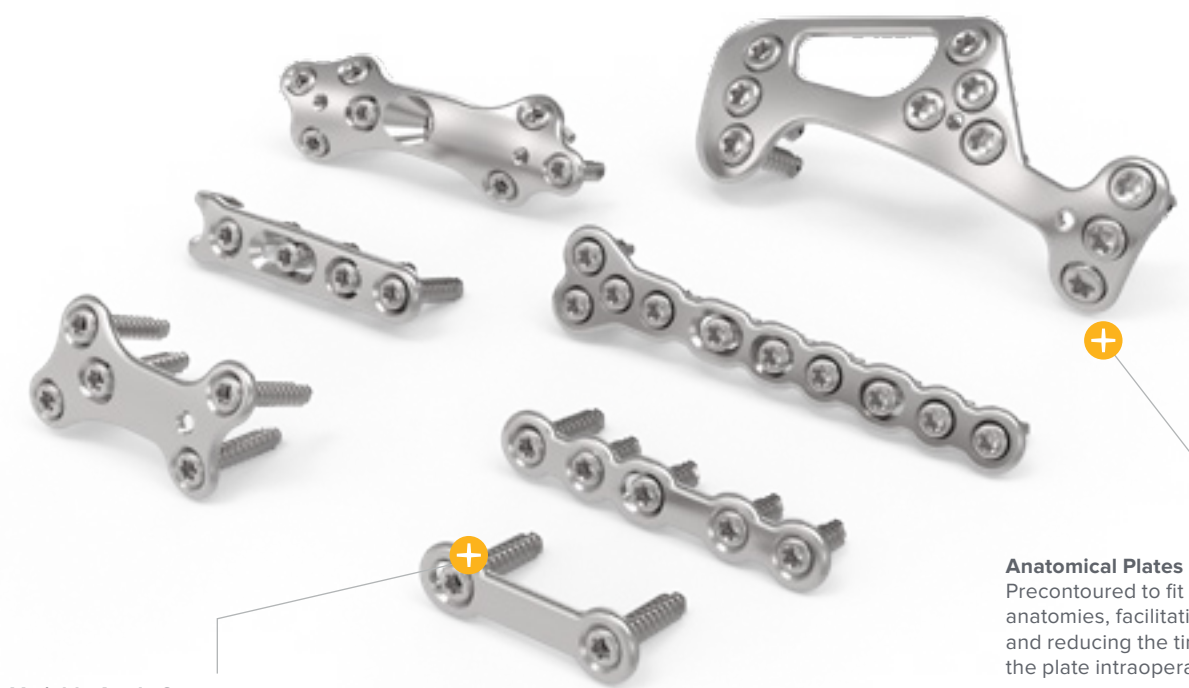

**Variable Angle Screws**

Variable angle locking screw and plate technology designed for fixation in various fracture patterns and patient anatomies

**Anatomical Plates**

Precontoured to fit simple to complex anatomies, facilitating plate placement and reducing the time needed to bend the plate intraoperatively

**Large Angle Lock**

40 degrees of polyaxial locking assist in capturing difficult bone fragments; 360 degrees of screw and plate contact create a strong locking construct for plate fixation



Lapidus Plates



H Plates



1<sup>st</sup> MTP Fusion Plates



Utility Plates

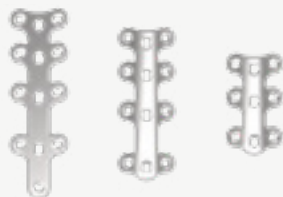

Medial Column Plates

# FPS™ Foot Plating System

The OsteoMed Foot Plating System includes 80 plates with the latest in variable angle locking screw and plate technology to treat multiple reconstructive and trauma applications of the forefoot, midfoot, and hindfoot. Dedicated instrumentation in this comprehensive system allows for multiple intraoperative options to accommodate surgical variation and patient anatomy.



Mini Fragment System Plates	Holes	Length	Thickness
-----------------------------	-------	--------	-----------

FPS Straight Plates	4, 5, 6-Hole		2.0 mm
FPS T Plate, Locking	7-Hole		2.0 mm
FPS T Plate, Compression	7-Hole		2.0 mm
FPS Y Plates	6, 7-Hole		2.0 mm
FPS L Plate, Left & Right	6-Hole		2.0 mm
FPS Oblique L Plates, Left & Right	6-Hole		2.0 mm
FPS Oblique T Plate, Right	7-Hole		2.0 mm

Small Fragment System Plates	Holes	Length	Thickness
------------------------------	-------	--------	-----------

FPS Step Plates		0-5 mm	2.7 mm
FPS Wedge Plates (Length: 0, 1, 2, 3, 4, 5 mm)			2.7 mm
FPS Lapidus Plates, Left & Right (Length: 0, 2.0, 2.5, 3.0, 3.5, 4.0, 4.5, 5.0 mm)			2.7 mm
FPS Straight Compression Plates	4, 5, 6, 7-Hole		2.7 mm
FPS Oblique L Compression Plates, Left & Right	6-Hole		2.7 mm
FPS Oblique T Compression Plates, Left & Right	6-Hole		2.7 mm
FPS T Plate	6-Hole		2.7 mm
FPS L Plates, Left & Right	6-Hole		2.7 mm

Medium Fragment System Plates	Holes	Length	Thickness
-------------------------------	-------	--------	-----------

FPS Straight Plates	4, 6, 8, 10, 12-Hole		3.5/4.0 mm
FPS Oblique T Plates	10-Hole		
FPS Oblique T Plates, Left & Right	6, 10-Hole		
FPS Medial Column Plates		Small	
FPS Medial Column Plates		Large	
FPS Wedge Plates (Length: 2, 4, 6, 8, 10 mm)			3.5 mm
FPS Step Plates (Length: 6, 8, 10 mm)			3.5/4.0 mm
FPS H Plates	15, 20, 30-Hole		4.0 mm
FPS Calcaneal Plates		56, 65, 74 mm	
FPS Calcaneal Plates, Template		56, 65, 74 mm	

MTP/MPJ Plates	Holes	Length	Thickness
----------------	-------	--------	-----------

FPS 1st MTP/MPJ Plate, Left & Right		Small	2.7 mm
FPS 1st MTP/MPJ Plate, Left & Right		Primary	2.7 mm
FPS 1st MTP/MPJ Plate, Left & Right		Large	2.7 mm
FPS Subcondylar Plate			2.7 mm
FPS Navicular Cuneiform Fusion Plate		Small	2.7 mm
FPS Navicular Cuneiform Fusion Plate		Large	2.7 mm
FPS Hook Plate, Left & Right			2.7 mm
FPS Hook Plate		Short	2.7 mm

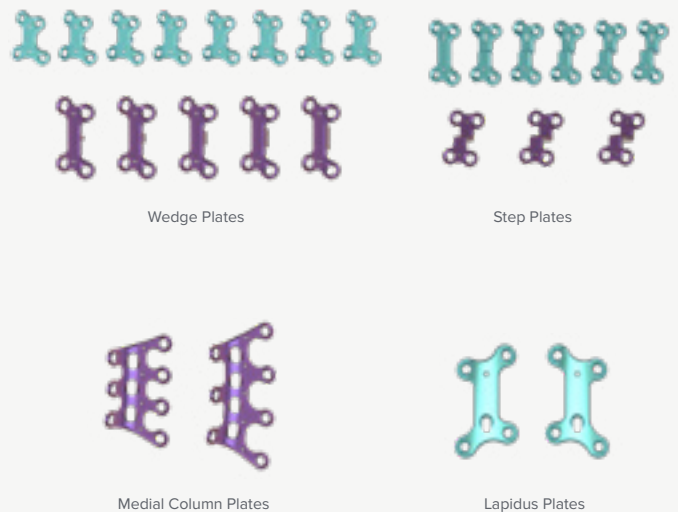



**Variable Angle Screws**

Variable angle locking screw and plate technology designed for fixation in various fracture patterns and patient anatomy

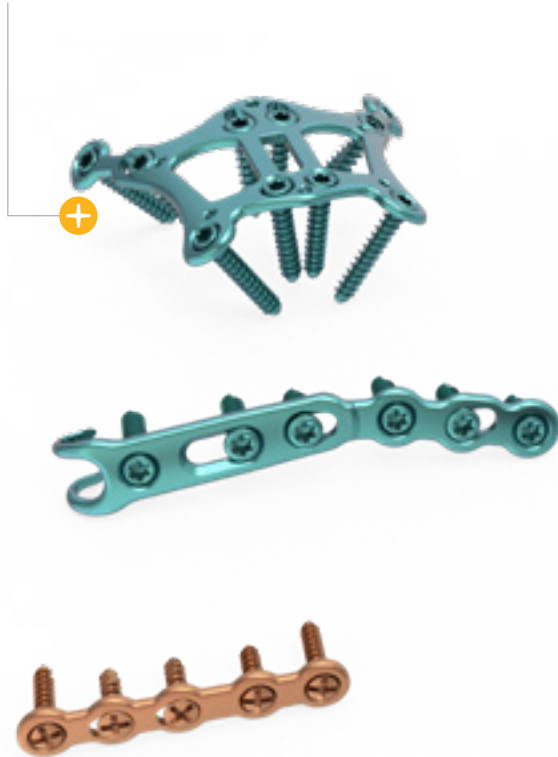
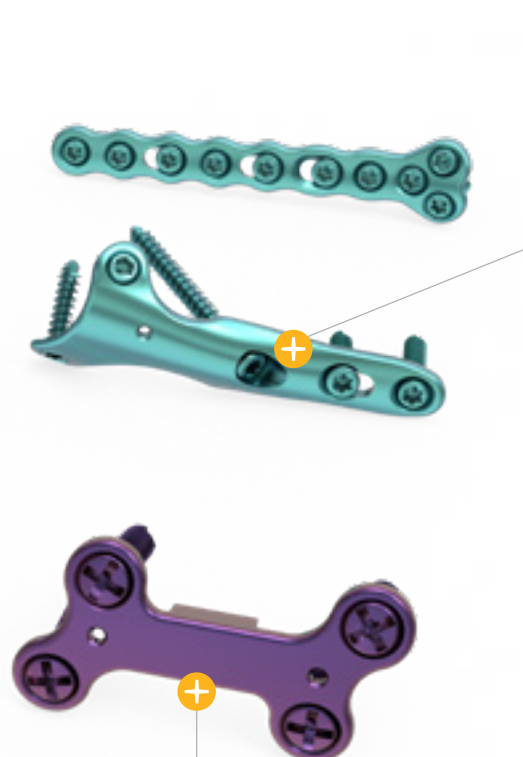

**Plate Options**

Offers 80 plates options over three fragment modules to treat multiple reconstructive and trauma applications of the forefoot, midfoot, and hindfoot

**Transfixation Technology**

Allows for placement of an interfragmentary screw through the plate to prevent plantar gapping. Plates also include compression holes for additional stability



**Color-coded plates and screws**

2.0 mm Bronze, 2.7 mm Green, 3.5/4.0 mm Purple

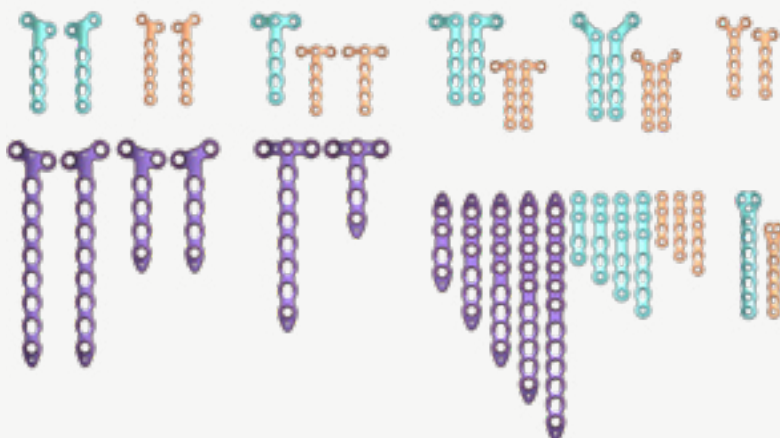

Fragment Plates



Navicular Cuneiform Plates

Hook Plates



MTP/MPJ Plates



## Forefoot/Midfoot Plating System

The Acumed Forefoot/Midfoot Plating System addresses both acute fractures and reconstruction of the foot, including hallux valgus revision, Lisfranc fracture fixation, and proximal metatarsal osteotomies.

Tarsometatarsal (TMT) Plates	Plate Length	Thickness
4-Hole Locking 1st Tarsometatarsal Plate	48 mm	1.5 mm
4-Hole Locking 2nd & 3rd Tarsometatarsal Plate	45 mm	1.5 mm
5-Hole Locking 1st Tarsometatarsal Plate	50 mm	1.6 mm
7-Hole Locking 1st Tarsometatarsal Plate	82 mm	1.5 mm
7-Hole Locking 2nd & 3rd Tarsometatarsal Plate	79 mm	1.5 mm
8-Hole Locking 1st Tarsometatarsal Plate	84 mm	1.0 mm

Metatarsophalangeal (MTP) Plates	Plate Length	Thickness
Locking Dorsal MTP Fusion Plate 9°, Left, Right	50 mm	1.6 mm
Locking MTP/MPJ Combo Fusion Plate, 9°, Left, Right	50 mm	1.6 mm
Locking MTP Revision Fusion Plate, 9°, Left, Right	62 mm	1.6 mm
Locking MTP Petite Plate 4°, Left, Right	40 mm	1.3 mm
Locking Dorsal MTP Plate 4°, Left, Right	50 mm	1.6 mm
Locking MPT/MPJ Combo Plate 4°, Left, Right	62 mm	1.6 mm
Locking MTP Revision Plate 4°, Left, Right	62 mm	1.6 mm

Osteotomy Plates	Plate Length	Thickness
Locking Proximal Metatarsal Wedge Plate, Left, Right	32 mm	1.6 mm
Locking Proximal Metatarsal Wedge Plate, 0°, Left, Right	50 mm	1.6 mm

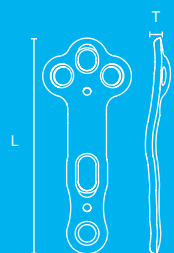

Tarsometatarsal (TMT) Plates

**Locking and Nonlocking Screws**

A choice of 3.0 or 3.5 mm hexalobe screws and 4.0 mm cancellous screws (2.7 and 3.5 mm hex screws optional)

**TMT Plates**

Designed to minimize the need for plate bending in tarsometatarsal fractures, fusions, and osteotomies

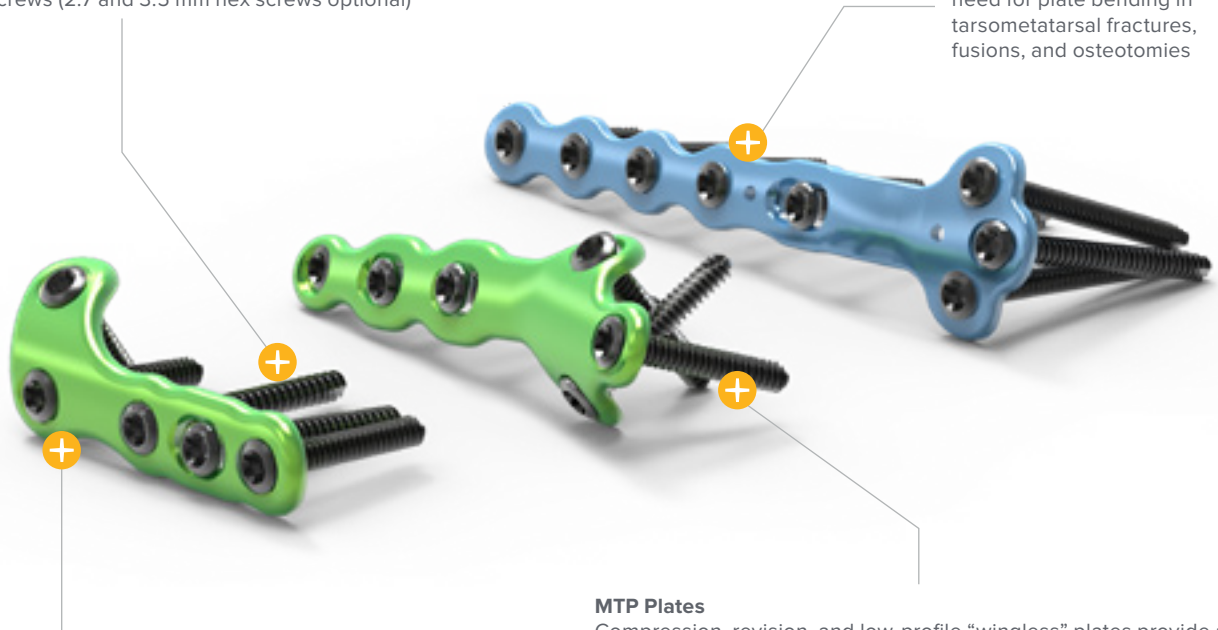

**Osteotomy Plates**

Buttress to postoperative shifting of the distal metatarsal angle, the plates provide compression at the osteotomy site during healing

**MTP Plates**

Compression, revision, and low-profile “wingless” plates provide a variety of options for treating metatarsophalangeal joint fractures, fusions, and osteotomies

**Small Joint Reamers**

Solution for creating congruent bone surfaces prior to fusion procedures with Acumed plates, Acutrak® screws, and other methods of fixation

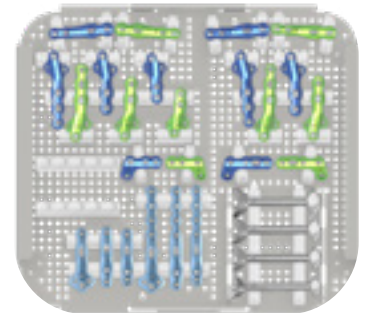

9° Metatarsophalangeal (MTP) Plates



Osteotomy Plates



4° Metatarsophalangeal (MTP) Plates

**Approach-specific Design**

MINI-Calc® Plates are specifically designed to be inserted through a sinus tarsi incision, which provides visibility of the subtalar articular surface to aid in fracture reduction

**Locking Calcaneal Plate**

The plate is recommended for the lateral wall right-angle extensile surgery approach



**Low-profile**

The 1.27 mm thick MINI-Calc Plates are designed to minimize soft-tissue irritation

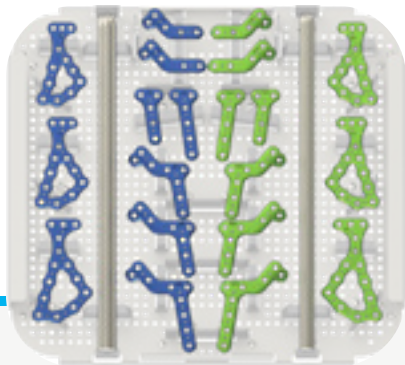

**Fragment-specific Options**

The system offers a variety of plates to accommodate different fracture types, whether comminution is present in the anterior process, through the posterior facet, or in the posterior tuberosity

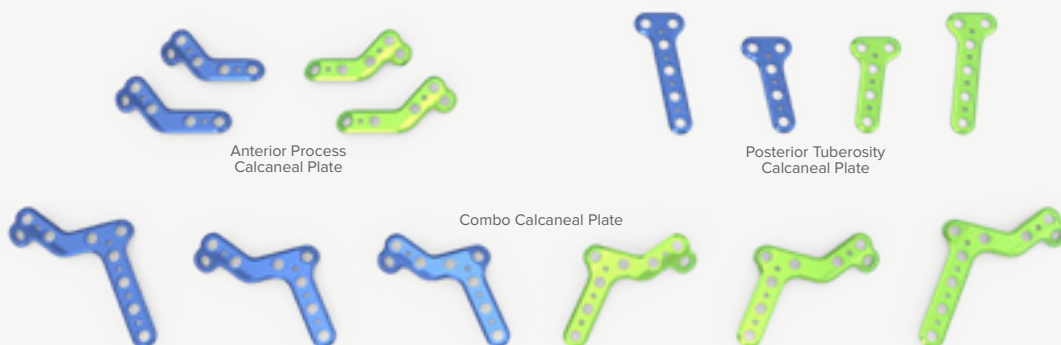

Anterior Process Calcaneal Plate

Posterior Tuberosity Calcaneal Plate

Combo Calcaneal Plate

## Calcaneal Plating System

Designed to deliver a new level of performance, versatility, and reliability for calcaneal fractures, the Acumed Calcaneal Plating System includes MINI-Calc® plates intended for use in a sinus tarsi approach that may reduce the potential for soft-tissue irritation.

MINI-Calc Plates	Plate Length	Thickness
Anterior Process Calcaneal Plate, Medium, Left, Right	41 mm	1.27 mm
Anterior Process Calcaneal Plate, Large, Left, Right	45 mm	1.27 mm
Posterior Tuberosity Calcaneal Plate, 5-Hole, Left, Right	19 mm	1.27 mm
Posterior Tuberosity Calcaneal Plate, 6-Hole, Left, Right	21 mm	1.27 mm
Combo Calcaneal Plate, Medium, 8-Hole, Left, Right	41 mm	1.27 mm
Combo Calcaneal Plate, Large, 8-Hole, Left, Right	45 mm	1.27 mm
Combo Calcaneal Plate, Large, 9-Hole, Left, Right	47 mm	1.27 mm

Locking Calcaneal Plates	Plate Length	Thickness
Locking Calcaneal Plate, Small, Left, Right	57 mm	0.5 mm
Locking Calcaneal Plate, Medium, Left, Right	63 mm	0.5 mm
Locking Calcaneal Plate, Large, Left, Right	71 mm	0.5 mm



**Two Screw Configurations**  
Two types of anterior-most screws, a long bicortical screw and a short unicortical screw, help to provide the stability necessary for fixing the anterior process

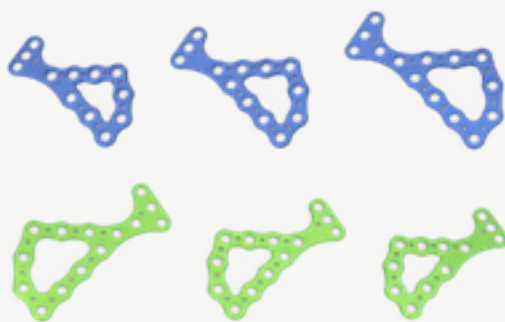

Locking Calcaneal Plate



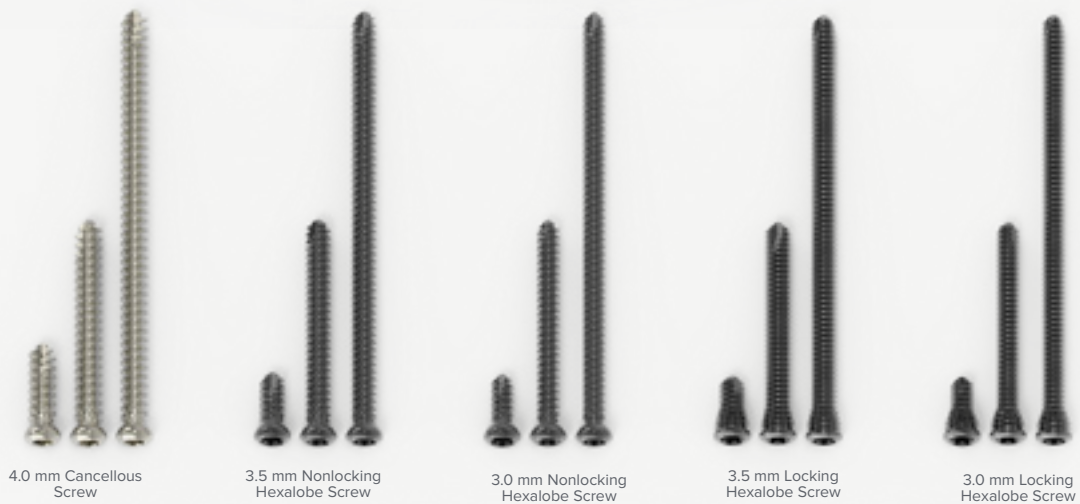
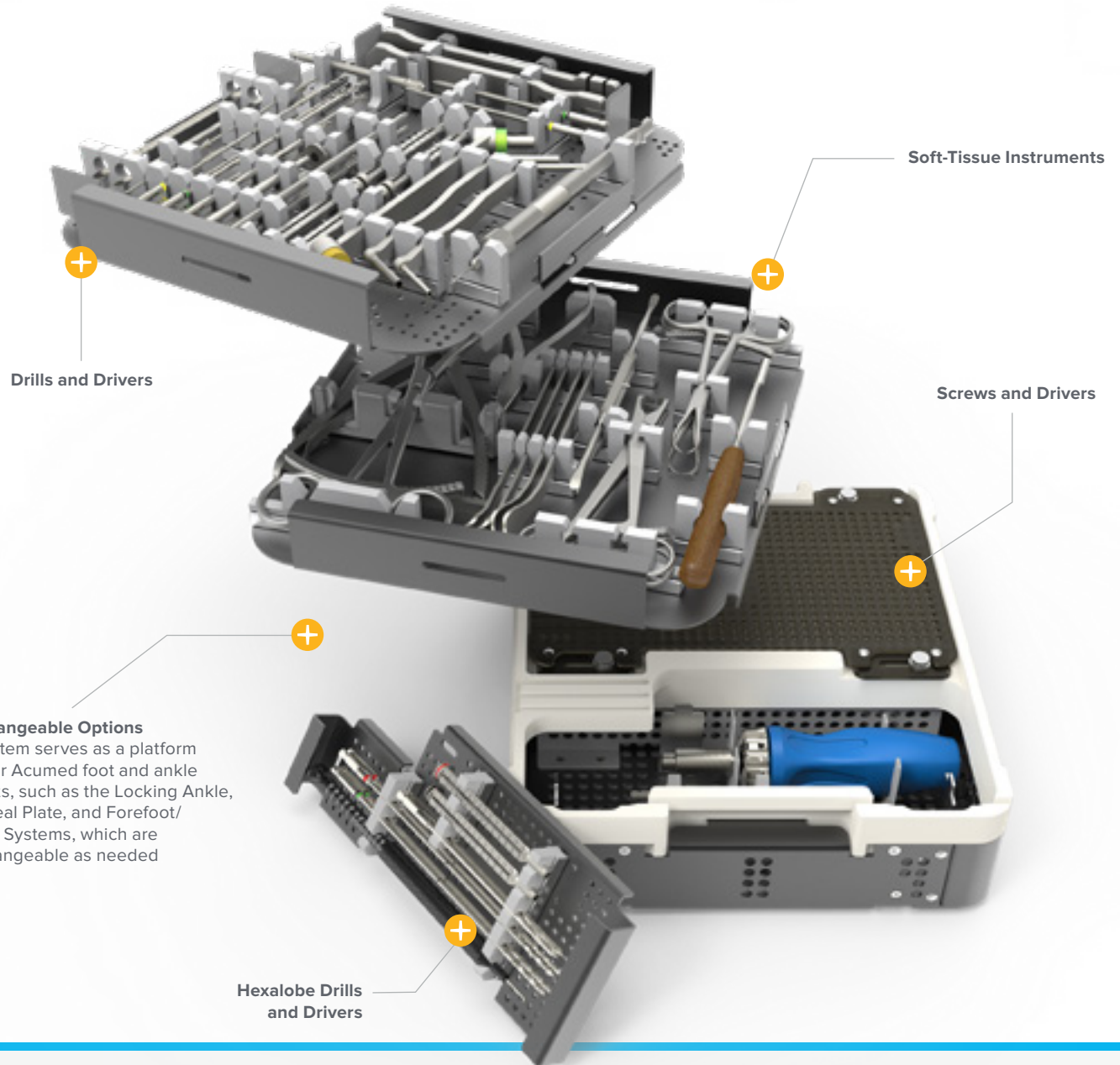



## Lower Extremity Modular System

The Acumed Lower Extremity Modular System supports multiple combinations of existing implant trays. An intuitive screw caddy, locking drill guides with integrated sizing, and an extensive array of lower-extremity-specific instrumentation is designed to improve efficiency and help streamline the operating room experience.

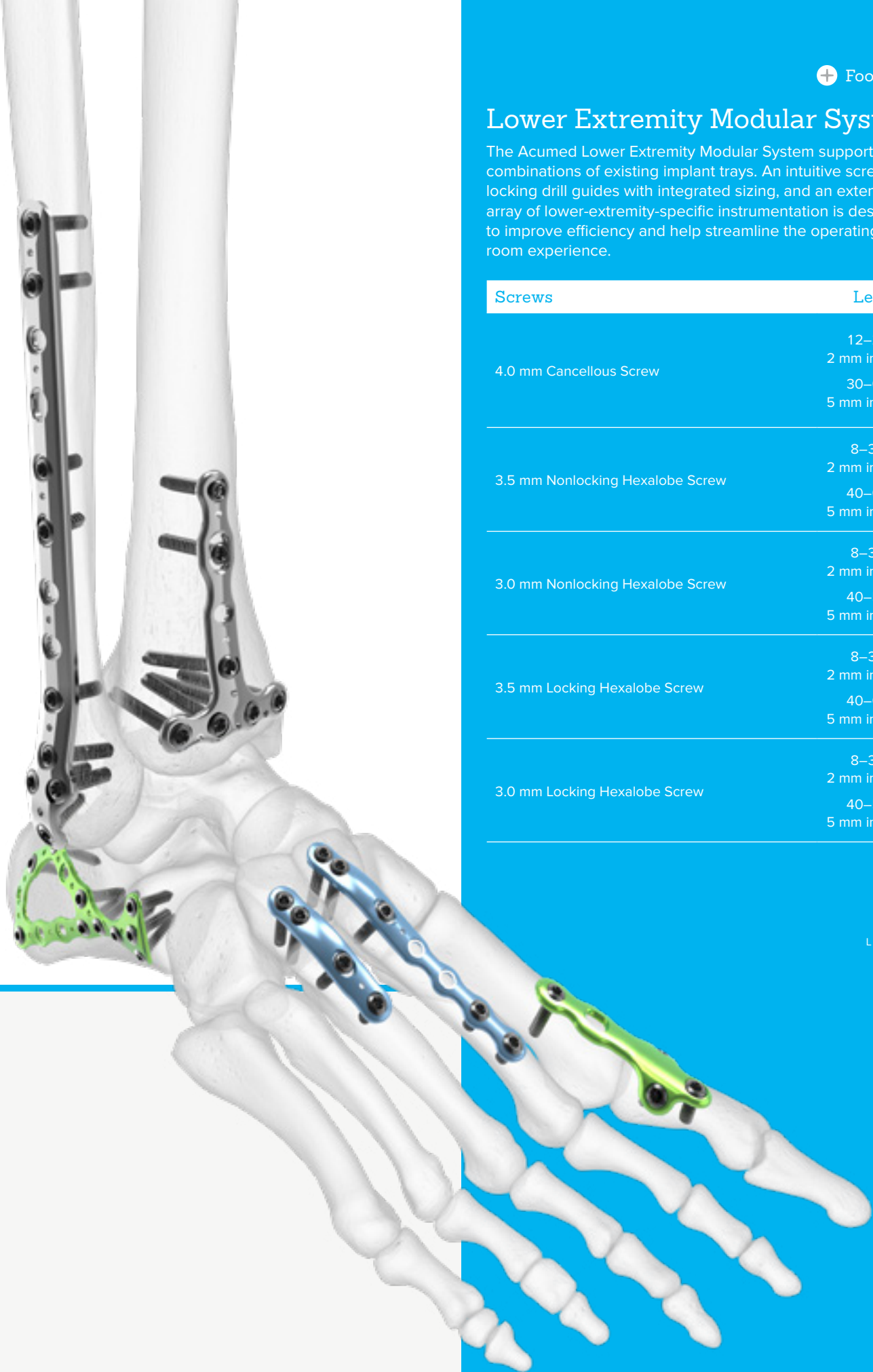

Screws	Length
4.0 mm Cancellous Screw	12–28 mm
	2 mm increments
	30–60 mm 5 mm increments
3.5 mm Nonlocking Hexalobe Screw	8–38 mm
	2 mm increments
	40–60 mm 5 mm increments
3.0 mm Nonlocking Hexalobe Screw	8–38 mm
	2 mm increments
	40–55 mm 5 mm increments
3.5 mm Locking Hexalobe Screw	8–38 mm
	2 mm increments
	40–60 mm 5 mm increments
3.0 mm Locking Hexalobe Screw	8–38 mm
	2 mm increments
	40–55 mm 5 mm increments

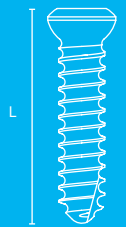

## Small Joint Reamer System

The Acumed Small Joint Reamer System can be used in both the upper and lower extremities. The reamers are designed to create stable, congruent bone surfaces in the MTP, MCP, IP, and DIP joints prior to fusion procedures with Acumed plates, Acutrak 2® screws, or other methods of fixation.

Small Joint Reamers	Diameter
Concave Reamer	10 mm
Concave Reamer	12 mm
Concave Reamer	14 mm
Concave Reamer	16 mm
Concave Reamer	20 mm
Concave Reamer	24 mm
Convex Reamer	10 mm
Convex Reamer	12 mm
Convex Reamer	14 mm
Convex Reamer	16 mm
Convex Reamer	20 mm
Convex Reamer	24 mm



### Potential Upper Extremity Application

Fit phalanges together in desired flexion and fix with an MCP plate from the Acumed Modular Hand System or with an Acutrak 2 screw for DIP fusions



### Potential Lower Extremity Application

Create desired fit for MTP fusions when paired with the MTP plates found in the Acumed Locking Forefoot/Midfoot Plating System



### Specialized Instrumentation

System includes Reamer Gauges to assist in determining sizing prior to reaming the bone surface

**Cannulated Body**  
Cannulation accepts a .059" guide wire to facilitate targeted reaming of bone surface

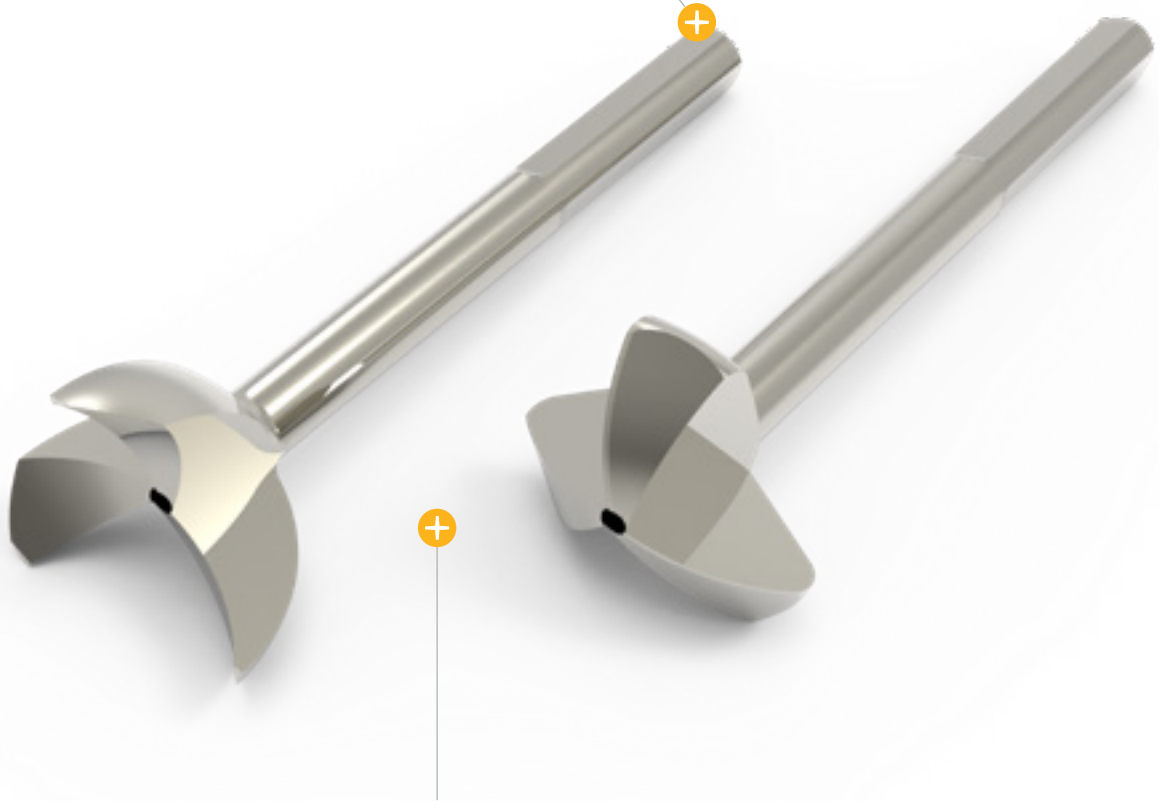

**Cutting Flutes**  
Designed to clear bone debris during use

Reamers are available in 10 mm, 12 mm, 14 mm, and 16 mm sizes for the fingers and thumb and 20 mm and 24 mm sizes for the great toe



Concave Reamers

Convex Reamers

**5 Implant Sizes**

Multiple implant options accommodate various patient anatomies in pediatric and adult patients

**Cannulated Implants**

Facilitates accurate implant insertion and positioning



**Blunt Threads**

Reduces bone impingement and irritation

**Cone Shape Design**

Provides superior blockage of the talus through a minimally invasive technique that does not require bone or cartilage resection

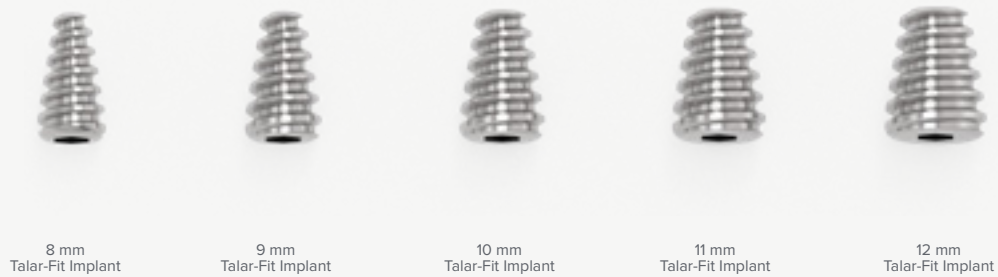

8 mm  
Talar-Fit Implant

9 mm  
Talar-Fit Implant

10 mm  
Talar-Fit Implant

11 mm  
Talar-Fit Implant

12 mm  
Talar-Fit Implant

## Talar-Fit™ Subtalar Arthroereisis Implant

The OsteoMed Talar-Fit™ Subtalar Arthroereisis Implant is designed to provide subtalar blockage in the treatment of flatfoot deformity in adult and pediatric patients. The cone-shaped implant is intended for a minimally invasive technique that does not require bone or cartilage resection. Five implant size options accommodate various patient anatomies.

Subtalar Arthroereisis Implants	Lateral Height	Medial Height	Length
Subtalar Arthroereisis Implant	8 mm	4 mm	15 mm
Subtalar Arthroereisis Implant	9 mm	5 mm	15 mm
Subtalar Arthroereisis Implant	10 mm	6 mm	15 mm
Subtalar Arthroereisis Implant	11 mm	7 mm	15 mm
Subtalar Arthroereisis Implant	12 mm	8 mm	15 mm
Locking Talar-Fit™ Surgical Kit, Sterile			

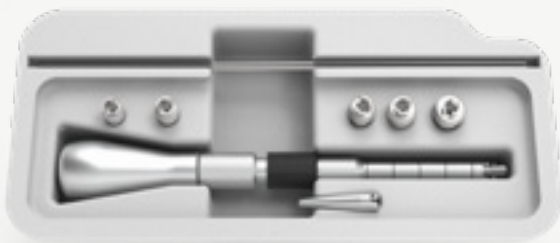
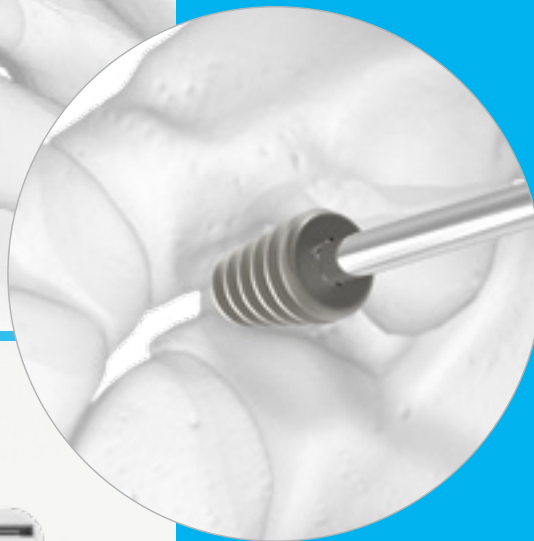
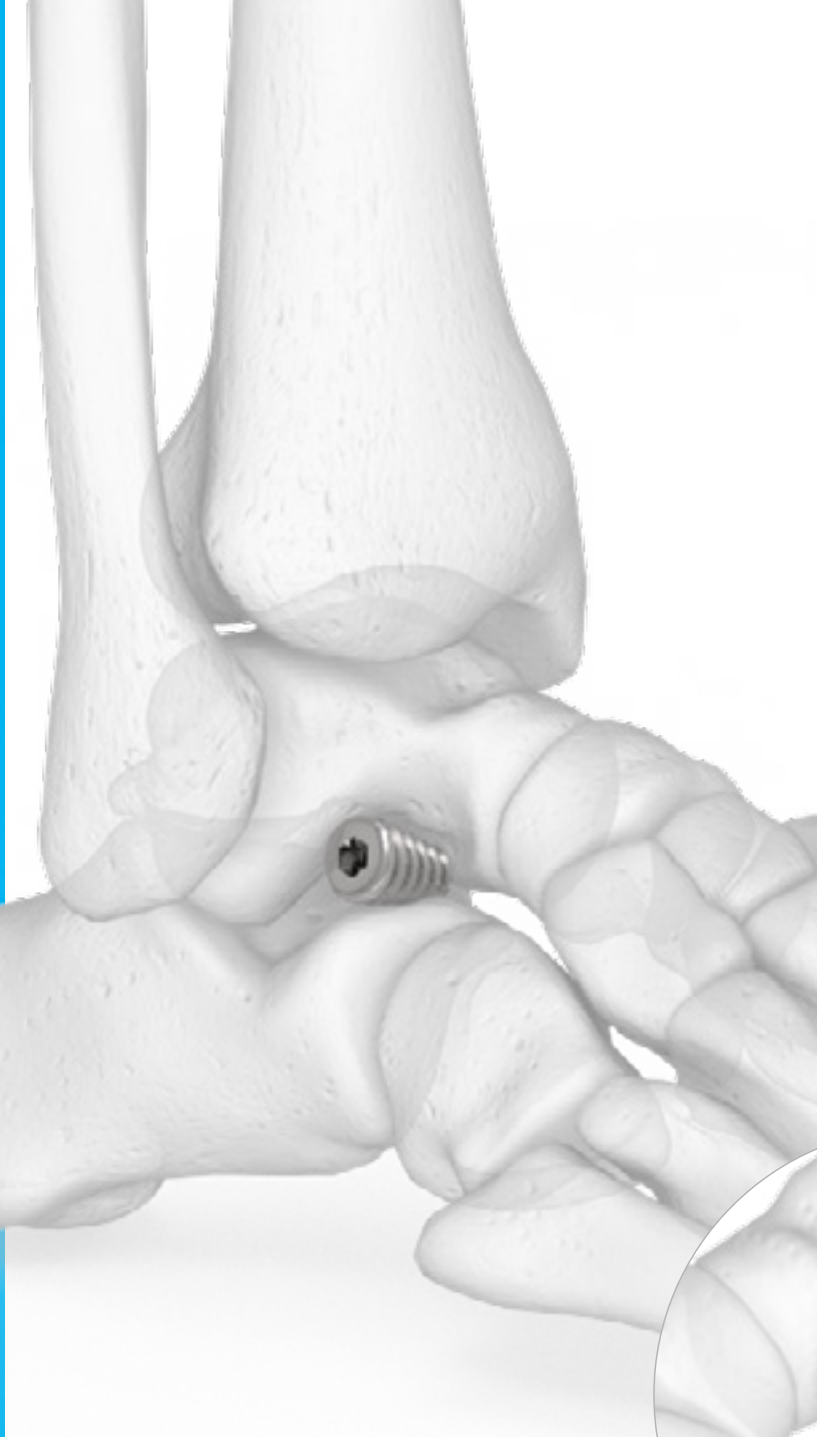

Talar-Fit Sterile Instrument Kit

### Subtalar Blockage

Provides subtalar blockage in the treatment of flatfoot deformity, allowing normal subtalar joint motion



## EnCompass™ Metatarsal Resurfacing Implant

The OsteoMed® EnCompass™ Metatarsal Resurfacing Implant is a one-piece implant anatomically designed to decompress the Metatarsal Phalangeal Joint and remodel the articulating surface of the metatarsal head. The implant is available in seven sizes to accommodate individual anatomies while minimizing bone removal. The four-finned stem provides EnCompass with anti-rotation stability, while a Titanium spray and Hydroxyapatite coating promote osseointegration.

Metatarsal Resurfacing Implants	Diameter	Stem Length	Stem Diameter
EnCompass Lesser Trial	10 mm	13 mm	3.5 mm
EnCompass Lesser Trial	12 mm	13 mm	3.5 mm
EnCompass Trial	15 mm	14 mm	5.0 mm
EnCompass Trial	16 mm	14 mm	5.0 mm
EnCompass Trial	17 mm	14 mm	5.0 mm
EnCompass Trial	18 mm	14 mm	5.0 mm
EnCompass Trial	19 mm	14 mm	5.0 mm



### Smooth Articulating Surface

When fully seated, the implant covers the metatarsal head and provides a smooth articulating surface while deterring bony overgrowth

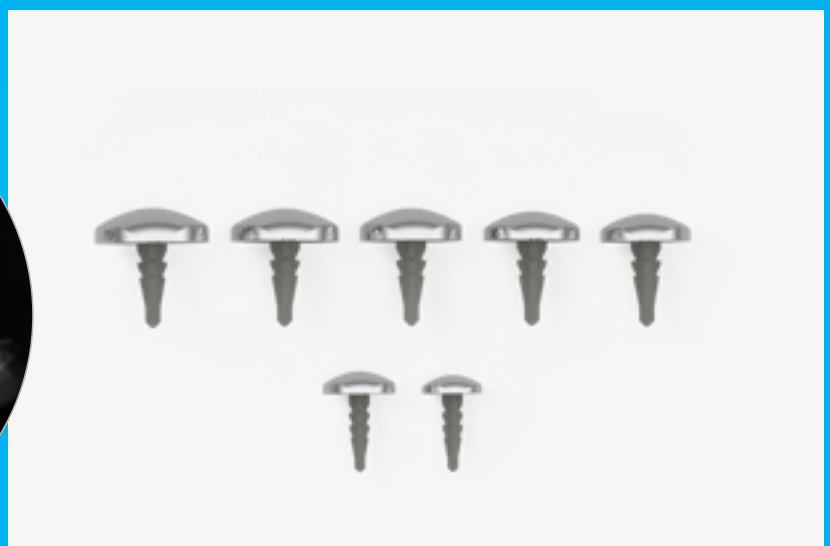

EnCompass Implants

**7 Sizes**

Accommodates individual anatomies and promotes minimal bone removal

**Material**

Articulating surface is made of cobalt-chrome, implant undercoating is made with titanium and hydroxyapatite spray, and stem coating is made with hydroxyapatite spray

**Anatomic Head**

Provides a smooth articulating surface with mirror finish



**Four-Finned Stem**

Designed to provide rotational stability, while titanium spray and hydroxyapatite coating are intended to promote osseointegration



**Color-coded System**

Drill guides are color-coded for easy use and identification

**Reamers**

Reestablish proper joint spacing while resurfacing the metatarsal for a precise implant fit

**One-Piece Solution**

Featuring low-profile head and stem, providing greater clinical adaptability

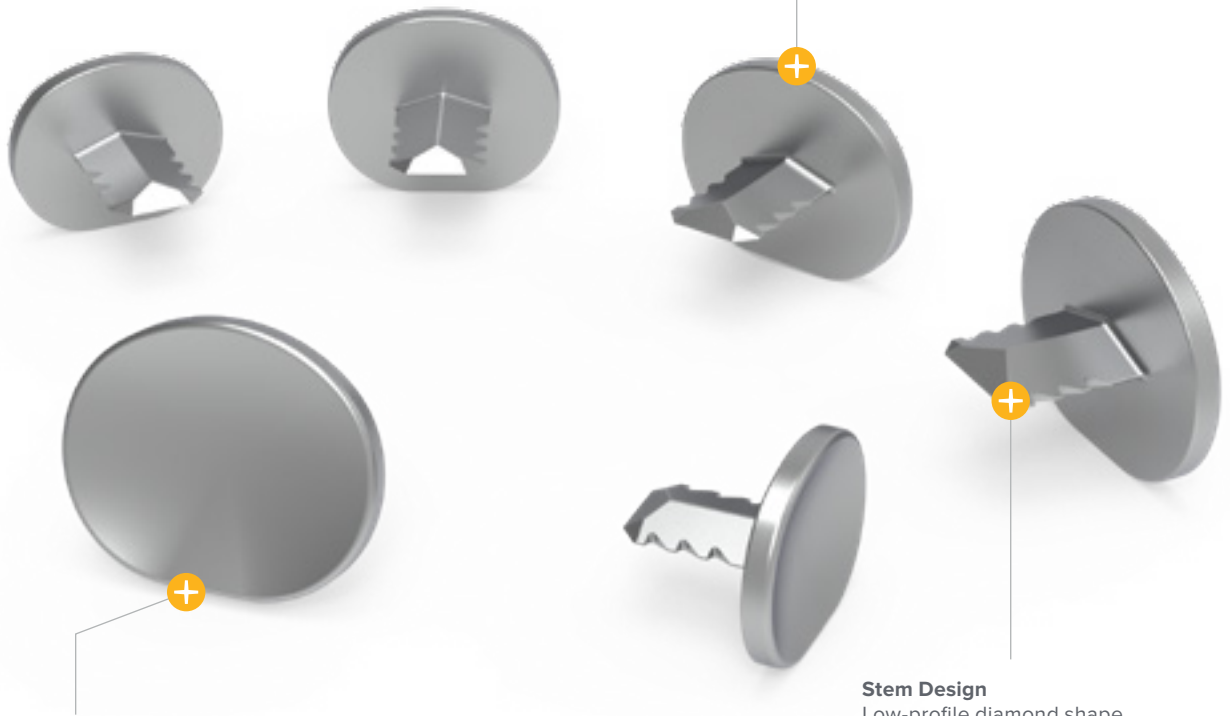

**Smooth Articulating Surface**

Anatomically shaped cobalt-chrome alloy implant minimizes friction, providing greater pain-free motion

**Stem Design**

Low-profile diamond shape stem offers a press fit fixation and antirotation stability

Four implant sizes ensures precise anatomical fit



Hemi Great Toe Implant, Extra Small

Hemi Great Toe Implant, Small

Hemi Great Toe Implant, Medium

Hemi Great Toe Implant, Large

## Hemi™ Great Toe Implant

The OsteoMed Hemi™ Great Toe Implant is designed as a one-piece solution for arthroplasty of the first metatarsal phalangeal joint. The anatomically shaped implant offers a low-profile articulating surface, allowing for minimal resection of the patient's native proximal phalanx.

Great Toe Implants	Size	Head Height	Head Width
Hemi Great Toe Implant	Extra Small	14.5 mm	17.5 mm
Hemi Great Toe Implant	Small	16 mm	19 mm
Hemi Great Toe Implant	Medium	17.5 mm	21 mm
Hemi Great Toe Implant	Large	19 mm	23 mm

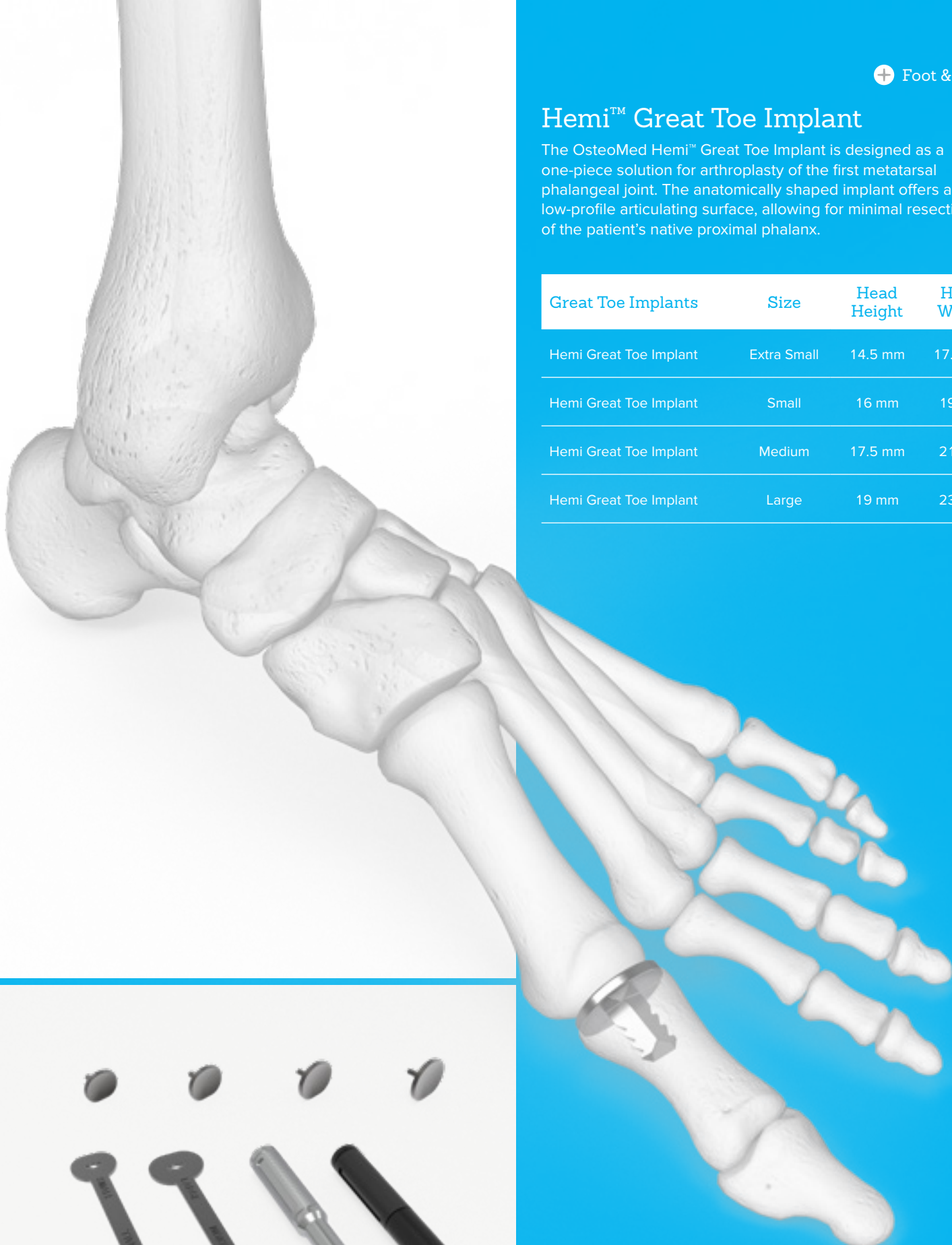

Hemi Great Toe Implant,  
Instrument Kit

Instruments tray includes trial, sizer, punch, and impactor for convenient placement of the device

# ReFlexion™ 1<sup>st</sup> MTP Implant System

The OsteoMed ReFlexion 1<sup>st</sup> MTP Implant System is indicated for reconstruction of the severely disabled and/or painful metatarsophalangeal joints resulting from osteoarthritis, rheumatoid arthritis, or arthritis secondary to trauma or failure of prior arthroplasty. This three-piece implant offers 27 combinations of spherical head and stems to accommodate various patient anatomies.

1st MTP Implants	Size
ReFlexion Metatarsal Head	Standard
ReFlexion Metatarsal Head	Long
ReFlexion Metatarsal Head	Extra Long
ReFlexion Metatarsal Stem	Small
ReFlexion Metatarsal Stem	Medium
ReFlexion Metatarsal Stem	Large
ReFlexion Metatarsal Base	Small
ReFlexion Metatarsal Base	Medium
ReFlexion Metatarsal Base	Large

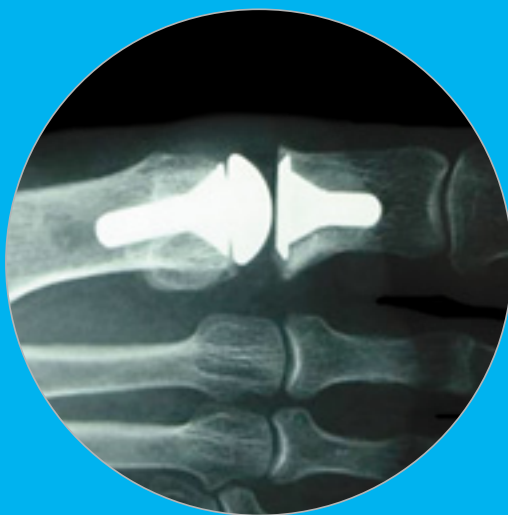

**Comprehensive System**

Assorted reamers provide patient-specific options that yield 27 different combinations while maximizing the interface between implant and cortical bone





**Cone Design**

Ensures maximum contact between the implant and cortical wall, providing inherent joint stability



**Multiple Combinations**

3-piece design offers 27 combinations of spherical head and stems to accommodate various patient anatomies



**Phalanx Inlay Component**

UHMWPE Phalanx interface provides strength and high resistance to abrasion wear



**17° Angled Metatarsal Stem**



**Spherical Head**

Cobalt-chrome head provides flexibility of the articulating surface, reducing wear of the phalangeal component

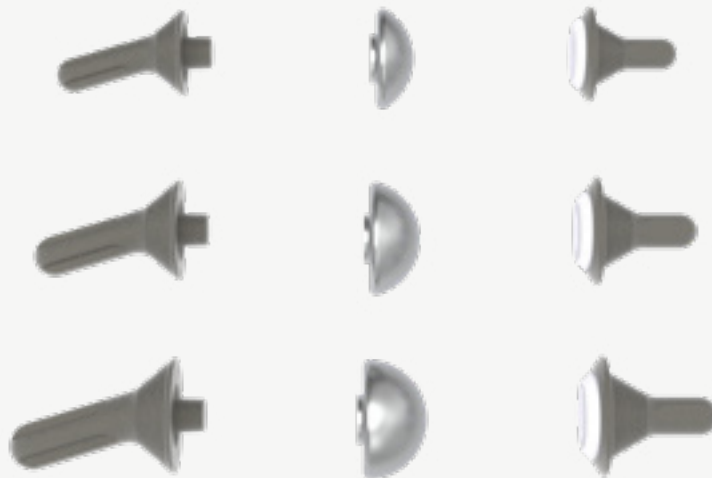

Metatarsal Stem

Metatarsal Head

Phalangeal Base

## ExtremiFuse™ Hammertoe Fixation System

The ExtremiFuse™ Hammertoe Fixation System is designed to treat hammertoe deformities of the lesser toes. Offered in three diameters at two angles, the system integrates OsteoMed's established screw technology with an innovative quad-barb design.

ExtremiFuse Implants	Size	Length
ExtremiFuse Implant 0°	2.0 mm	14 mm
ExtremiFuse Implant 0°	2.4 mm	18 mm
ExtremiFuse Implant 0°	3.0 mm	20 mm
ExtremiFuse Implant 10°	2.0 mm	14 mm
ExtremiFuse Implant 10°	2.4 mm	18 mm
ExtremiFuse Implant 10°	3.0 mm	20 mm

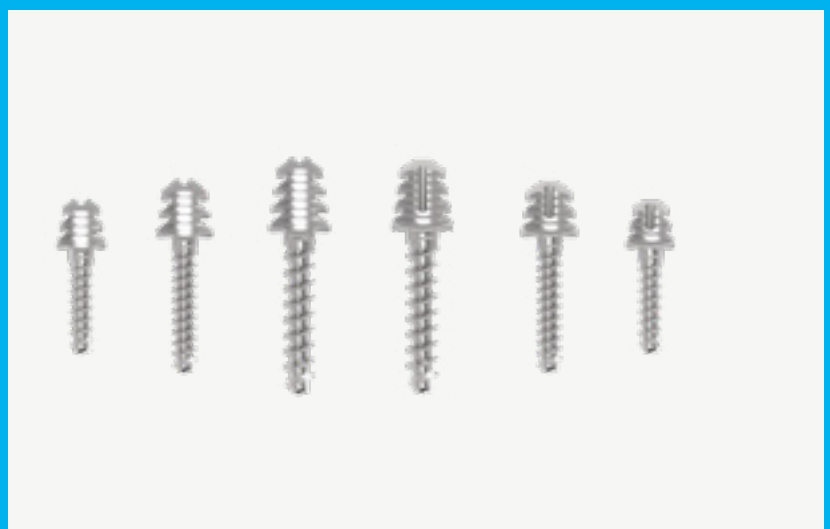

ExtremiFuse 0° Implants

ExtremiFuse 10° Implants

**One-piece Design**

Intramedullary implant design for the stabilization and fixation of lesser proximal interphalangeal joints for hammertoe correction



**Self-Drilling/Self-Tapping Screw Head**  
Smooth insertion into proximal phalanx; eliminates need for a proximal drill



**Quadbar Design**

Rectangular design provides 4 points of cortical contact maximizing directional stability, pullout resistance, and antirotational control

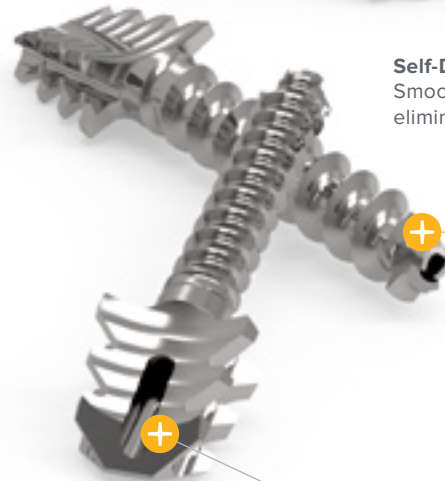

**Cannulated Implant**

Assures accurate placement down the central axis of the canal



**6 Implant Options**

0° and 10° implants available in 2.0, 2.4, and 3.0 mm thread diameters to provide fixation of lesser digits at the optimal angle

**Customizable Tray**

System holds 24 implants of any size and angle combination. Six rows of four can be customized

**Bulb**  
Helps maintain toe length and shape,  
and reduces toe migration



**Medical-grade Silicone**  
Minimizes inflammatory response

**Flexible Rod**  
Provides stabilization and helps maintain flexibility of the joint

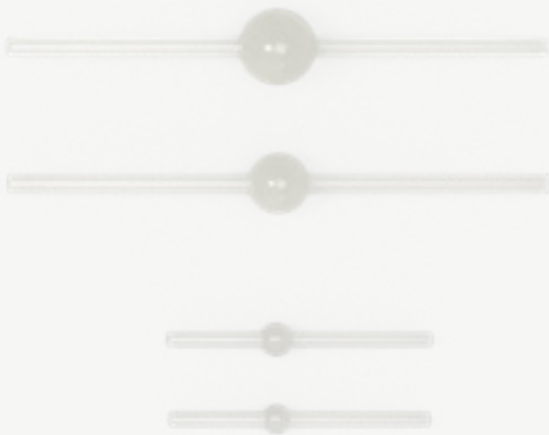

Interphlex™ Implants

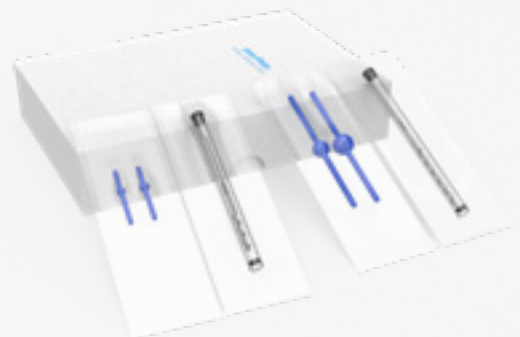

Interphlex Sterile Pack Kit

## InterPhlex™ Flexible Stabilization Rods

The OsteoMed InterPhlex Flexible Stabilization Rods are an alternative to arthrodesis of the metatarsophalangeal and interphalangeal joints of the lesser toes. The double-stemmed silicone implant is designed to maintain flexibility, length, and toe shape while addressing joint space stability and toe migration.

Stabilization Rods	Bulb Diameter	Distal Stem	Proximal Stem	Stem Diameter
Interphalangeal Stabilization Rod	4.0 mm	12 mm	18 mm	2.2 mm
Interphalangeal Stabilization Rod	4.5 mm	12 mm	18 mm	2.2 mm
Interphalangeal Stabilization Rod	8.0 mm	35 mm	35 mm	2.8 mm
Interphalangeal Stabilization Rod	10 mm	35 mm	35 mm	2.8 mm





## Calc-Jak

The Acumed Calc-Jak is an instrument designed to help pull displaced fractures of the calcaneus out to length to assist surgeons in restoring patient anatomy prior to fracture fixation.

### Pin Size

4.0 mm Threaded Pin, Quick Release

5.0 mm Threaded Pin, Quick Release

### Drill Size

3.0 mm Drill, 4.0 mm Shank, Quick Release

3.8 mm Drill, 5.0 mm Shank, Quick Release

### Parallel Pin Guide Size

4.0 mm Parallel Pin Guide

5.0 mm Parallel Pin Guide



### Sinus Tarsi Approach

The Calc-Jak System may be used with the minimally invasive sinus tarsi approach for treating calcaneus fractures with MINI-Calc® Plates

**Threaded Pins**

Available in two diameters (4.0 mm and 5.0 mm) to match the sizing needs and bone density of the patient



**Locking Cam-levers**

Closing the Cam-levers locks down the positioning of the calcaneus

**Fine Adjustment Block**

The fine-tune adjustment block allows for additional calcaneal translation after the Cam-levers have been locked

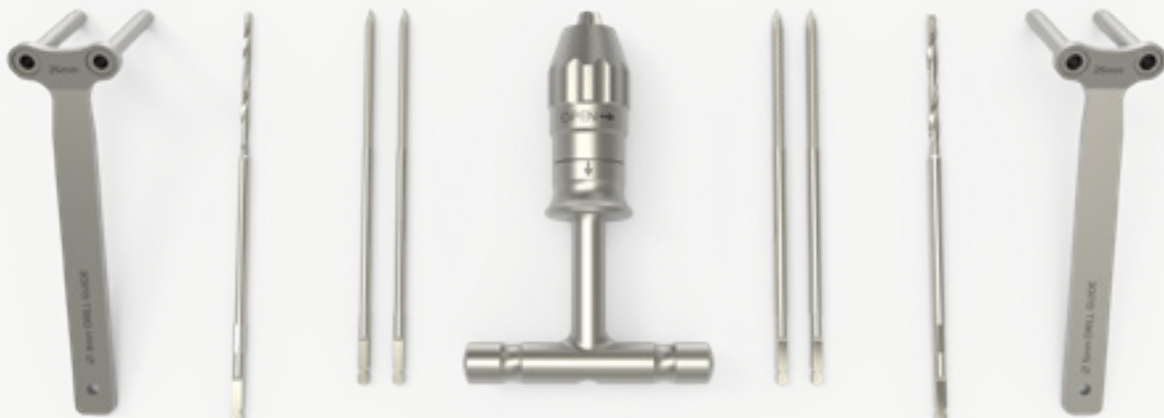

Calc-Jak Instrument System

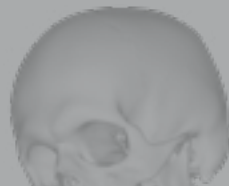

## Orthobiologics Product Lineup

Magnesium Phosphate Bone Void Filler .....	162
Allograft Nonstructural .....	164
Amniotic Membranes .....	166
Allograft Soft Tissue – Tendons .....	168
Allograft Structural .....	170
Bone Graft Harvesting System .....	172

**Magnesium Phosphate-based BVF**  
The first magnesium-based bone void filler in the orthopaedic marketplace\*



**Enhanced Remodeling**  
80% in 26 weeks



**Multiple Delivery Options**  
Moldable or injectable delivery and mixing options





## Magnesium Phosphate Bone Void Filler

The OsteoMed Magnesium Phosphate Bone Void Filler is the first magnesium-based bone void filler in the orthopaedic marketplace. It has an 80% rate of remodeling to normal bone in 26 weeks, with excellent binding characteristics. It can be used for defects resulting from trauma, infection, or compression fractures, post-reduction voids, or where high resorption is desired.

Magnesium Phosphate Bone Void Filler	Volume
Full Kit	5 cc
Kit Contents: Liquid & Powder Set, Mixing Syringe, Funnel, Basin, Spatula, and 11GA Cannula and 2GA Cannula	10 cc 15 cc
Basic Kit	5 cc
Kit Contents: Liquid & Powder Set, Basin & Spatula	10 cc 15 cc



Magnesium Phosphate Bone Void Filler in the Ankle



Magnesium Phosphate Bone Void Filler in the Knee

\*Data on file with OsteoMed

# Allograft Nonstructural

Sponges designed to compress and expand in bone voids.

DBM	Volume
	1 cc
	2.5 cc
DBM Putty	5 cc
	10 cc
	1 cc
	2.5 cc
DBM Crunch	5 cc
	10 cc
DBM Sponge 1–4 mm	5 cc and 10 cc

Cancellous Chips	Volume
Cancellous Chips 1–4 mm	5, 10, 15, 30 cc
Cortical-Cancellous Chips 1–4 mm	5, 10, 15, 30 cc
Cancellous Chips 1–4 mm	15, 30 cc
Cancellous Crushed 4–10 mm	10, 15, 30 cc
Cancellous Chips 4–10 mm	15cc, 30cc
Cortical-Cancellous Chips 4–10 mm	10cc, 15cc, 30cc

DBM Sponge Block	Size
	10 x 10 x 10 mm
DBM Sponge Block	12 x 12 x 12 mm
	14 x 14 x 14 mm
DBM Sponge Strip	35 x 20 x 7 mm
DBM Cancellous Strip	50 x 20 x 7 mm

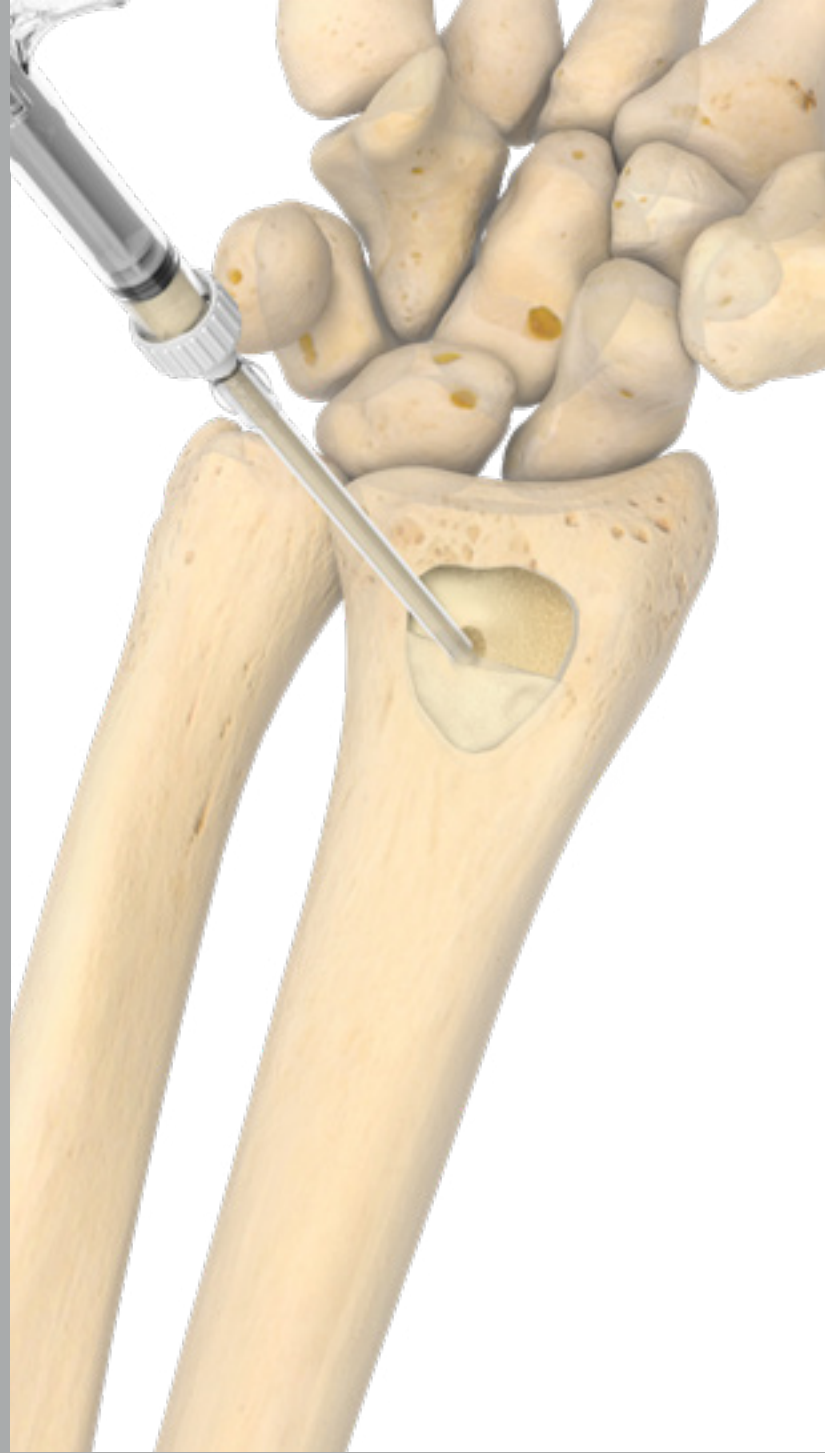



**Sponge Strips and Cubes**  
A range of sizes designed for optimal fit to help minimize waste

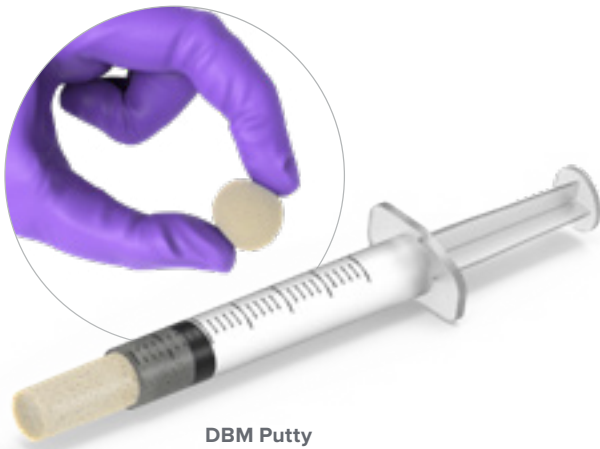

**DBM Putty**  
100% bone-derived, no inert carrier.  
Multiple sizes in putty and crunch forms



**Cancellous Chips**  
Small chips of allograft bone are used to fill voids and provide an osteoconductive scaffold for bony ingrowth



Cancellous Chips



10 x 10 x 10 mm

12 x 12 x 12 mm

14 x 14 x 14 mm

35 x 20 x 7 mm

DBM Sponge Blocks & DBM Sponges

Available as membrane

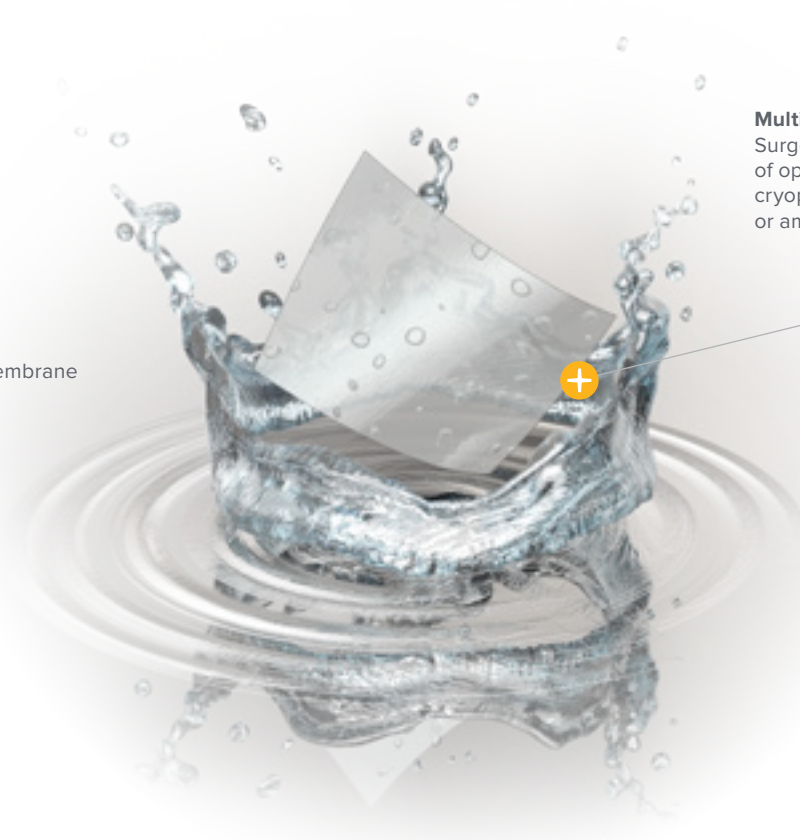

**Multiple Options**

Surgeons can choose from a wide variety of options: Hydrated, ambient temperature, cryopreserved. Single/dual layers, amnion-only or amnion/chorion combination grafts

Amnion Membrane

Chorion Membrane

Contains regenerative cytokines

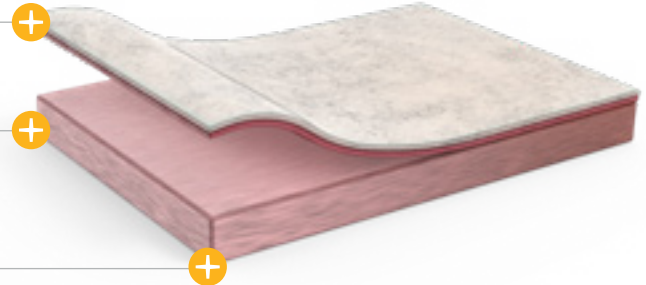

Amniotic Membrane Family Patches





## Amniotic Membranes

The Amniotic Membranes distributed by OsteoMed are used as a protective covering for reconstructive procedures and at fracture sites. Amniotic tissue is derived from placental amnion and is a rich source of key biological factors that promotes wound healing and tissue regeneration, controls pain and inflammation, reduces scar tissue, and acts as a general tissue covering.



Chronic wounds treated with amniotic tissue is faster than standard treatments

Amniotic Membrane	Size
Amnion Patch	1 x 1 cm
	1 x 2 cm
	2 x 2 cm
	2 x 3 cm
	2 x 4 cm
	2 x 6 cm
	4 x 4 cm
	4 x 6 cm
	4 x 8 cm
8 x 8 cm	
Amnion Disc	10 mm
	12 mm
	16 mm

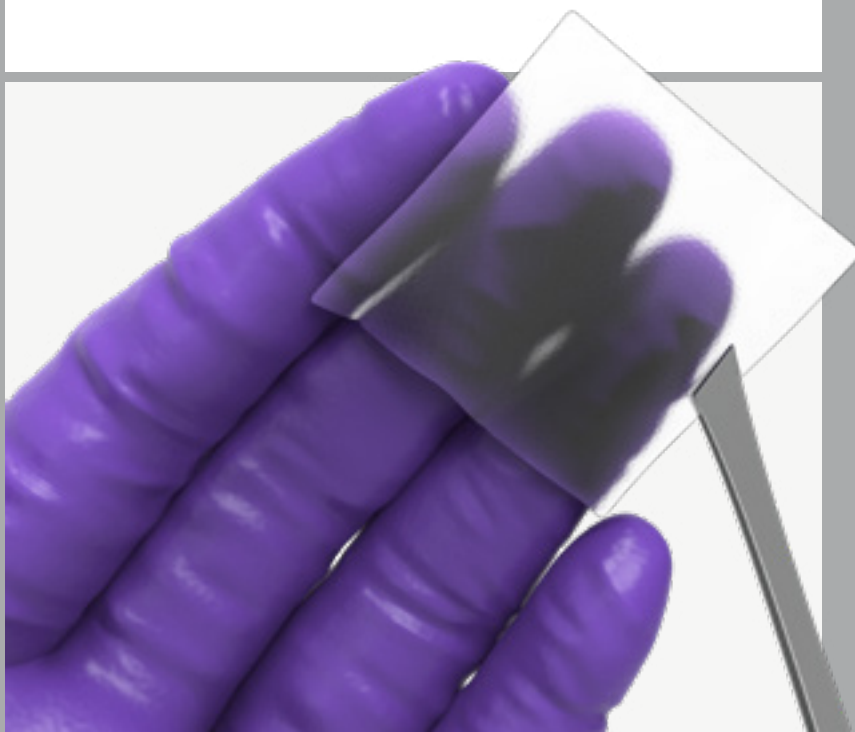

### Amniotic Membranes

Used as a covering for reconstructive procedures



## Allograft Soft Tissue – Tendons

Acumed offers a variety of tendon allografts for tendon repairs and reconstruction procedures distributed by OsteoMed. With a continuously updated stock of all major tendon allografts, we have the ability to accommodate specific ages and sizes to closely match the host. Our allografts meet FDA and AATB requirements for sterility by using low-dose gamma irradiation.

### Tendon Allografts

Achilles Tendon w/o Bone Block

Achilles Tendon w/Bone Block

Pre-Shaped Achilles Tendon

Gracilis Tendon

Patella-Hemi Achilles

Patella Tendon Whole

Patella Tendon Hemi

Pre-Shaped Patella

Peroneus Longus

Semitendinosus Tendon

Semitendinosus-Gracilis Tendon

Posterior Tibialis

Anterior Tibialis

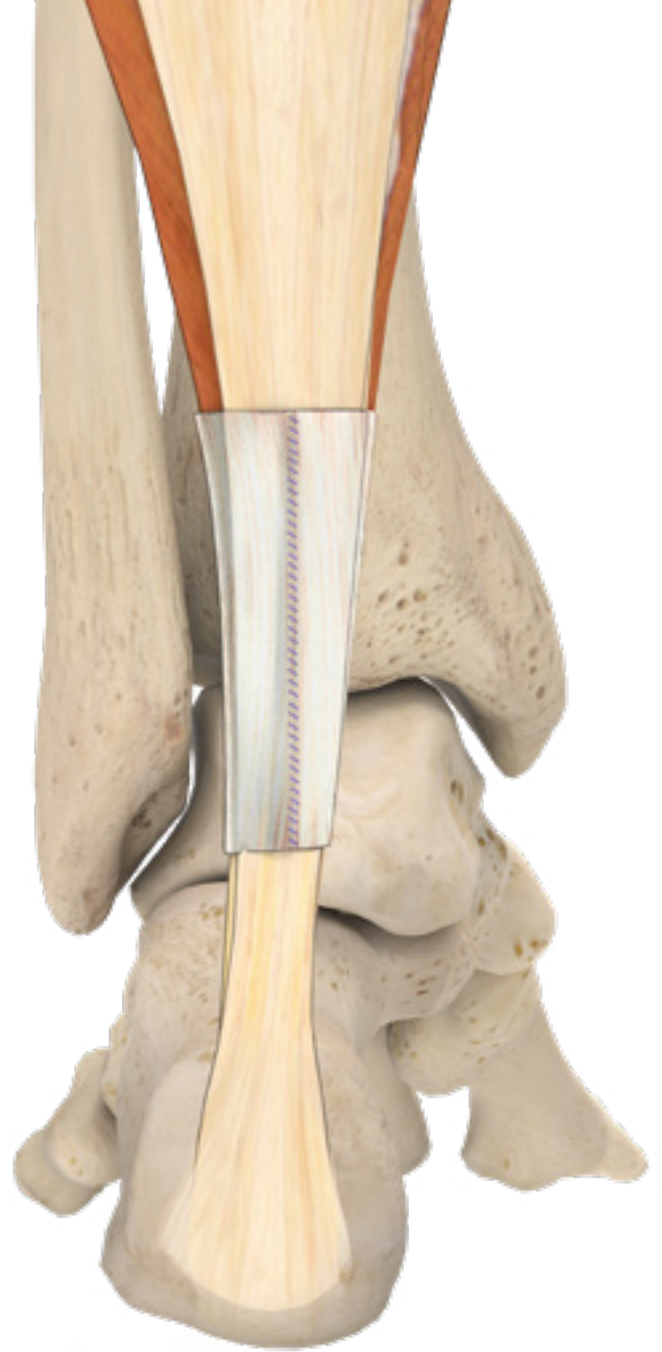

Patellar tendon reconstruction using an Achilles Tendon Allograft



Gracilis Tendon

**Peroneus Longus Tendon**

Considered the first-option graft in ACL reconstruction due to the absence of significant postoperative morbidity

**Achilles (With or Without Bone Block)**

Provides stability without the need to obtain a graft from the patient's own body

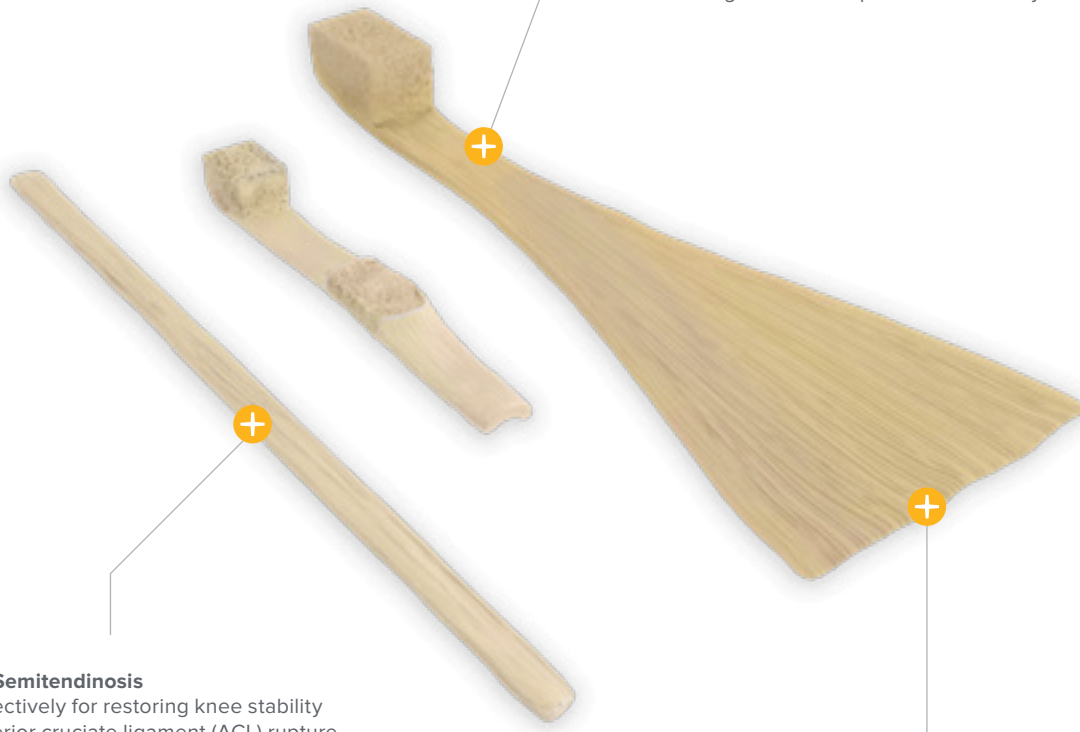

**Gracilis/Semitendinosus**

Used effectively for restoring knee stability after anterior cruciate ligament (ACL) rupture

**Anterior/Posterior Tibialis**

A thick, strong tendon that can be prepared with doubling of the graft



Achilles Tendon



Gracilis Tendon



Patella Tendon



Peroneus Longus



Semitendinosus Tendon



Posterior Tibialis



Anterior Tibialis



**Uncortical edges**

Preshaped, off-the-shelf solutions for Evans osteotomy procedures

Potential Uses:

- ▶ Evans/Cotton osteotomies
- ▶ Lengthening procedures



**Tricortical Blocks**

With cortical material on three sides, these grafts can be used where inherent structural support is required



**PrimaGraft Evans/Cotton Wedges**

Designed specifically to address the most common angles for both Evans and Cotton osteotomies



Tricortical Blocks

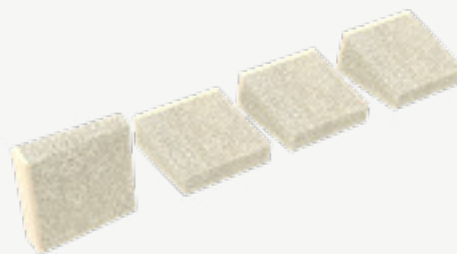

Uncortical Wedges

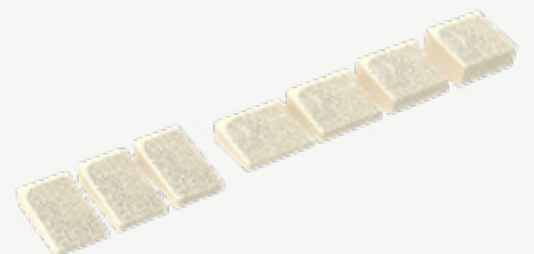

Evans/Cotton Wedges

## Allograft Structural

### Tricortical Blocks, Unicortical Wedges, PrimaGraft® Evans/Cotton

A wide variety of sizing options allow appropriate and precise correction to be achieved and eliminate the need for graft alterations. Tricortical blocks are also available to support lapidus procedures and MTP revision procedures that require natural structural support.



Tricortical Blocks	Size
	12 mm, W=12, L=25-3
	15 mm, W=15, L=25-3
	18 mm, W=18, L=25-3
Ilium TriCortical Block	25 mm, W=15, L=25-30, T1>1
	25 mm, W=15, L=25-30, T1>1
Iliac Crest Wedge	18 mm+

Unicortical Wedges	Size
	6 mm
	8 mm
Unicortical Wedge	10 mm
	12 mm

PrimaGraft® Evans/Cotton	Size
	5 mm
PrimaGraft Bicortical Cotton Wedge	6 mm
	7 mm
	6 mm
	8 mm
PrimaGraft Bicortical Evans Wedge	10 mm
	12 mm

#### PrimaGraft Instrumentation

- ▶ 4 Evans Trials
- ▶ 3 Cotton Trials
- ▶ Tamp
- ▶ Spreader

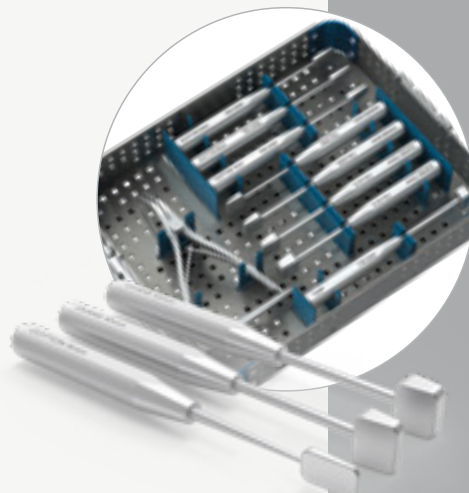

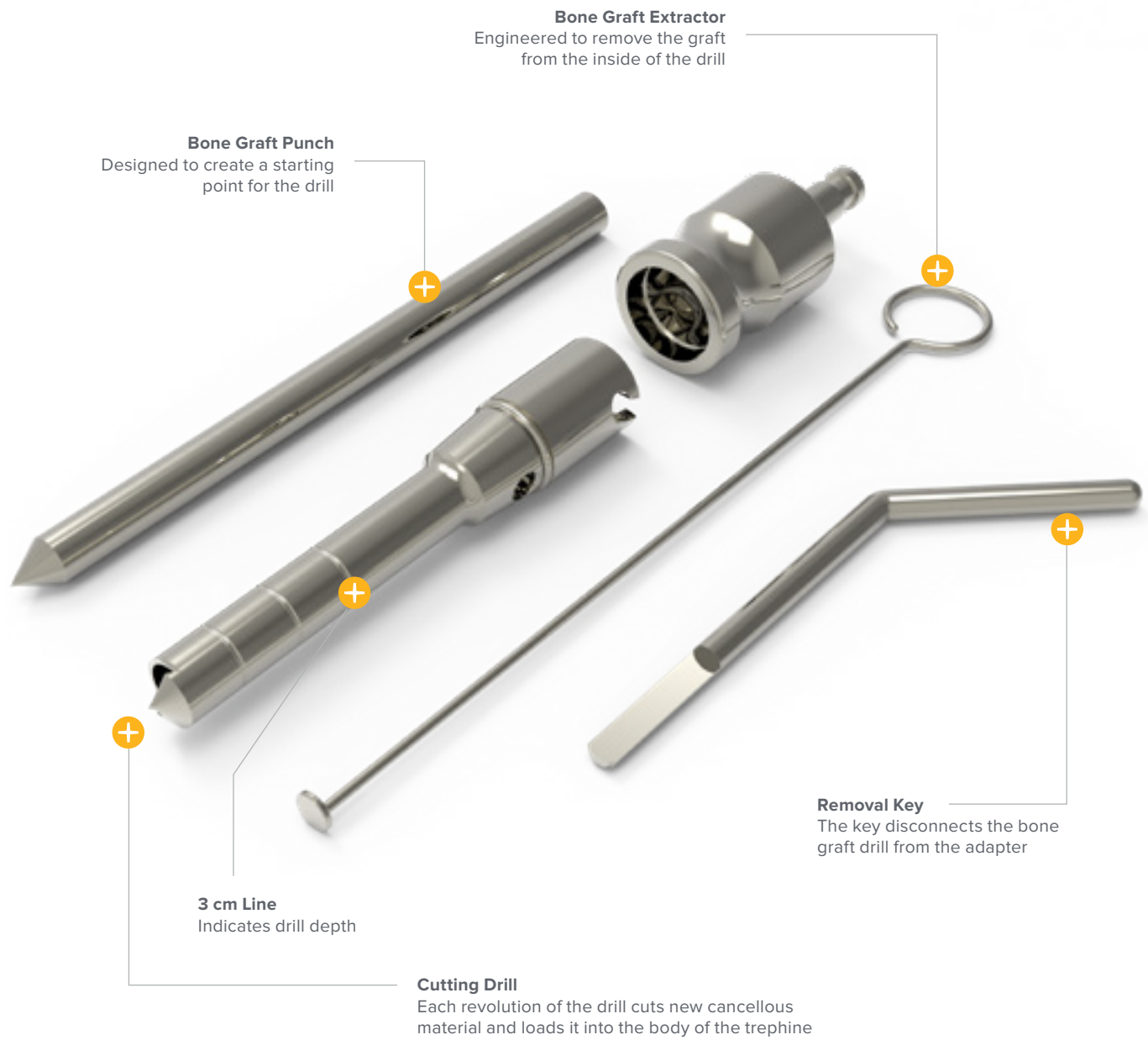

Bone Graft Drills

AO Quick Connect Bone Graft Drill



## Bone Graft Harvesting System

The Acumed Bone Graft Harvesting System facilitates rapid harvesting of morselized autogenous graft from the iliac crest, distal radius, and distal femur. This compact bone graft harvesting system is engineered to be straightforward to use and includes four drill size options, a power adapter fitting, a starting punch, a bone extractor, and a removal key.

The system allows for morselized bone graft removal through a small skin incision. The device attaches to a drill to extract the graft from the bone.

Bone Graft Drills	Drill Diameter	Graft Volume (at 3 cm)
Bone Graft Drill	6 mm	0.5 cc
Bone Graft Drill	8 mm	0.9 cc
Bone Graft Drill	10 mm	1.6 cc
Bone Graft Drill	12 mm	2.5 cc
AO Quick Connect Bone Graft Drill	7 mm	0.6 cc

All available single sterile-packed

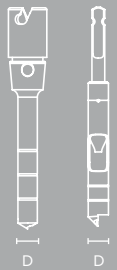

### Varying Morsel Size

Both the drill speed and the rate of insertion of the trephine are designed to vary the size of the bone chips



Tendon & Ligament Product Lineup

PEEK Suture Anchor .....176

Ankle Syndesmosis Repair System with Acu-Sinch® Knotless .....178

KobyGard™ ..... 180

**Convenient Handle Design**  
Needles retained inside the handle  
(MO-6 needles)

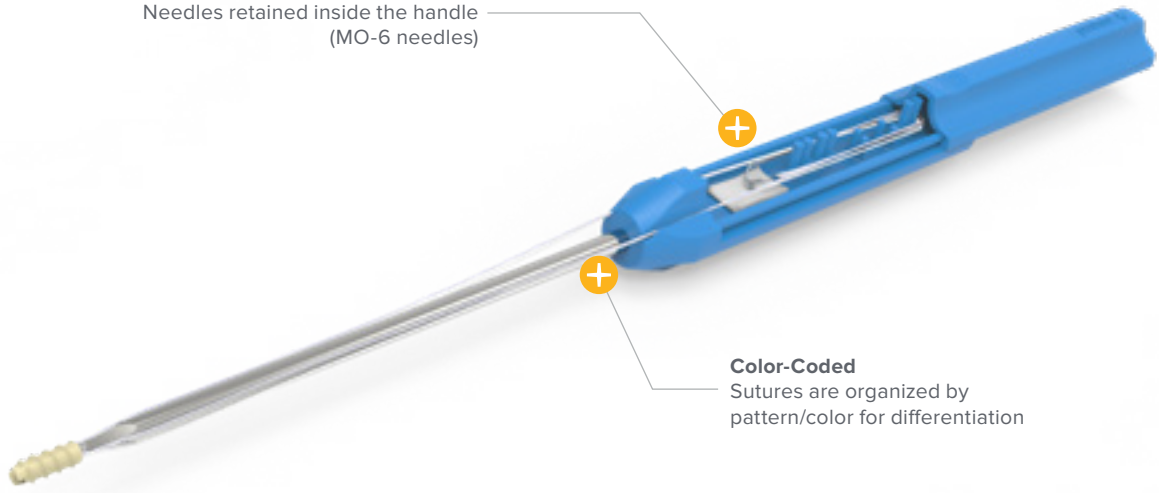

**Color-Coded**  
Sutures are organized by  
pattern/color for differentiation



**Double-Loaded Anchor**  
4.5 mm and 5.5 mm sizes double-loaded  
with #2 High Strength FlexBraid®. Sutures  
preloaded with curved needles



**Sterile-Packed Kits**  
Sterile packaged with drill and tap, or individually

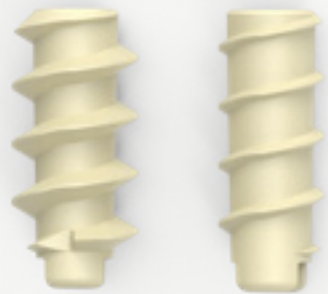

4.5 mm PEEK  
Suture Anchor

5.5 mm PEEK  
Suture Anchor

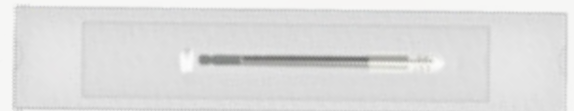
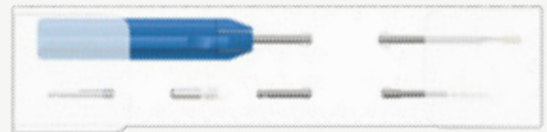

## PEEK Suture Anchor

The PEEK Suture Anchor provides surgeons with a series of products that address both complex fractures and soft-tissue injuries. It comes in 4.5 mm and 5.5 mm sizes that are double-loaded with two #2 High Strength FlexBraid® sutures on MO-6 Tapered Needles. Instrumentation includes a drill and tap, purchased sterile in a kit with anchor or separately.

PEEK Suture Anchor	Length
4.5 mm PEEK Suture Anchor	12 mm
5.5 mm PEEK Suture Anchor	12 mm

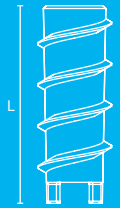
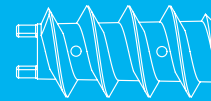

**Multiple Indications for Use**  
Can help repair a variety of issues in the elbow, shoulder, foot, and ankle



# Ankle Syndesmosis Repair System with Acu-Sinch® Knotless

Designed in conjunction with Alastair Younger, MB, Ch.B., M.Sc., Ch.M., FRCS(C); Selene Parekh, MD, MBA; and Steven Morgan, MD, the Acu-Sinch Knotless Implant enables the dynamic stabilization of laxity or syndesmotic disruptions to the tibiofibular joint. Its buttons may be augmented with a washer or used in conjunction with the Acumed and OsteoMed® fibula fracture fixation plates and intramedullary nails with 3.5 mm nonlocking screw holes.

Acu-Sinch Knotless	D1	D2
Acu-Sinch Round Button	6.5 mm	1.1 mm
Acu-Sinch Flip Button	3.2 mm	11 mm

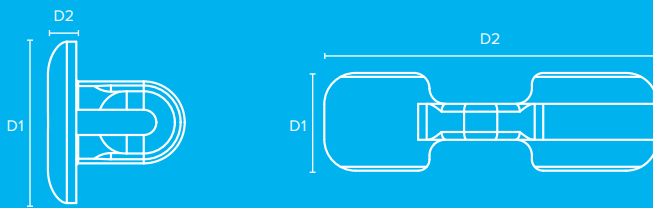

## Suture Creep Under Cyclic Loading

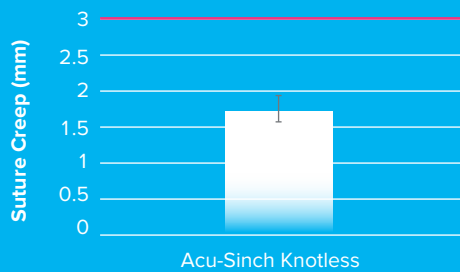

Clinically, a 3 to 4 mm separation or shift in the talus indicates syndesmotic instability.<sup>1</sup>

## Load to Failure After Dynamic Loading

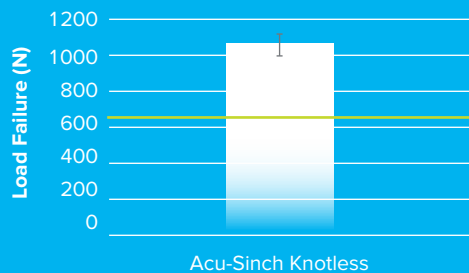

The average biomechanical strength under axial loading of the anterior tibiofibular ligament (part of the tibiofibular syndesmosis) is 625 N.<sup>2</sup>

1. Zalavras C, et al. Ankle syndesmotic injury. *J Am Acad Orthop Surg.* 2007 Jun;15(6):339.
2. Hoefnagels et al. 2007. Biomechanical Comparison of the Interosseous tibiofibular ligament and the anterior tibiofibular ligament. *Foot Ankle Int.* 2007 May;28(5):604.

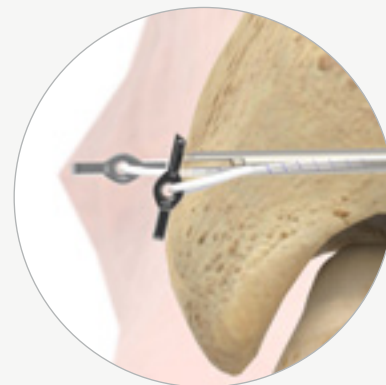

### Titanium Flip Button

Designed to pass through a 3.5 mm bone tunnel, plates, or intramedullary nails with a nonlocking 3.5 mm hole

**Knotless Repair System**

FlexBraid suture is a self-locking, high-strength suture that does not require a knot for secure fixation.



**Self-Locking Suture Loop**  
Made from #2 UHMWPE nonabsorbable HS Fiber, which enables an adjustable knotless repair



**Low-Profile Titanium Round Button**  
Compatible with a variety of titanium fibula plates with 3.5 mm nonlocking screw holes

**Compatible Acumed and OsteoMed® Plates**

- ▶ Fibula Rods
- ▶ Fibula Nail 2
- ▶ Ankle 3 Lateral Fibula Plates
- ▶ 1/3 Tubular Plates
- ▶ Locking Ankle System (LPL) Fibula Plates
- ▶ OsteoMed ExtremiLock™ Ankle Lateral Fibula Plates
- ▶ OsteoMed 1/3 Tubular Plates

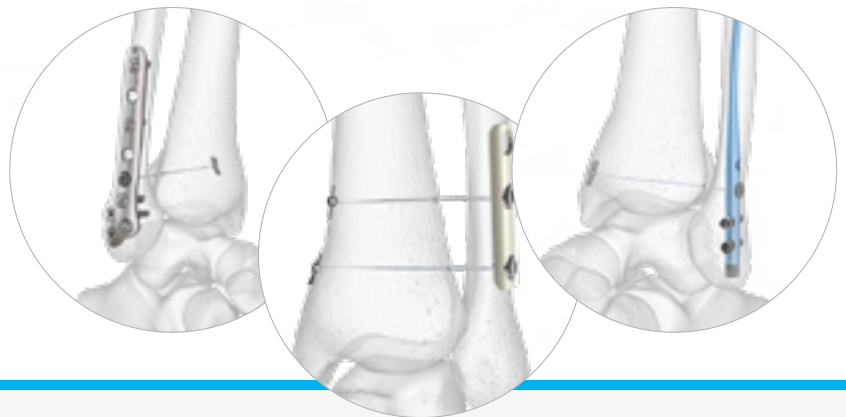

Acu-Sinch Washer

3.5 mm Fluted Drill



Acu-Sinch Knotless Inserter 3.5 mm

**Protects Surrounding Tissue**

Can safely isolate and create a precise predetermined cut of the transverse metatarsal ligament or plantar fascia, regardless of thickness, while protecting the surrounding tissue

**Effective Alternative**

Option for nerve excision surgery, endoscopic plantar fasciotomy, and open plantar fasciotomy



KobyGard System



Single-Use Blades, Sterile Packed

## KobyGard™

The KobyGard System is designed to address chronic plantar fasciitis and Morton's neuroma, two common soft-tissue foot indications. It offers minimally invasive solutions for plantar fasciotomy and nerve decompression while providing an alternative to endoscopic or open procedures.

### KobyGard System

KobyGard™ Sterile-Packed Single-Use Blade

KobyGard™ Sterile-Packed Single-Use Blade, 6 Pack

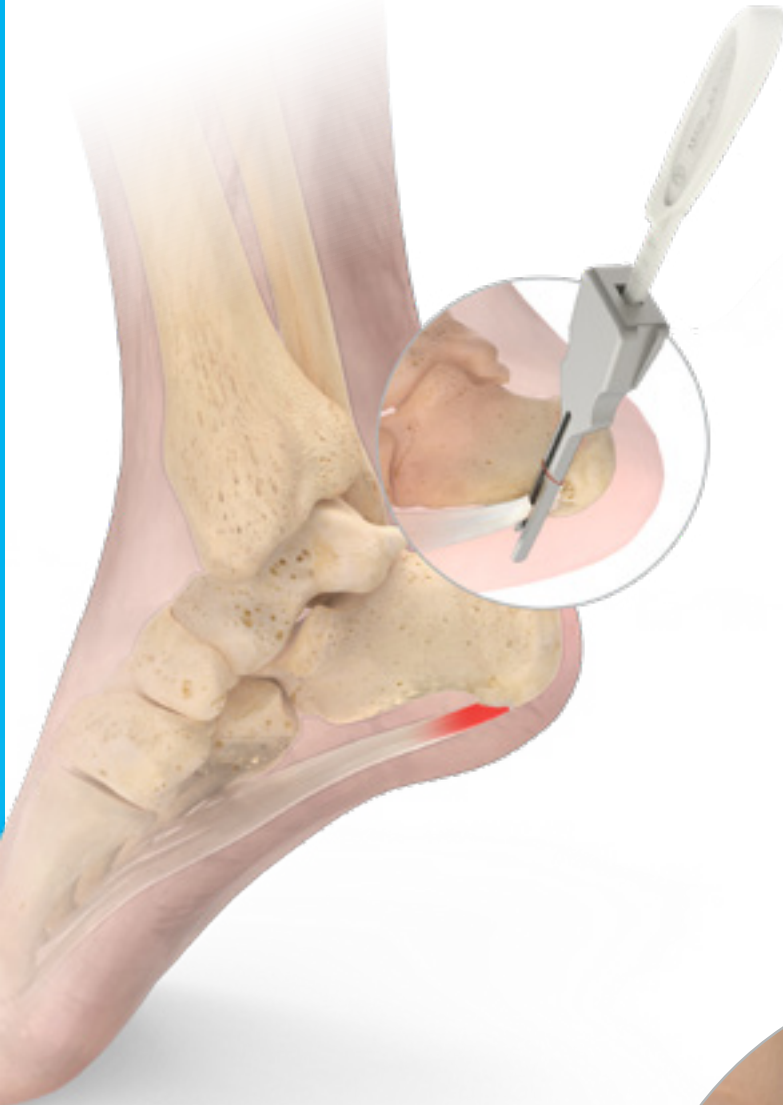

### MIND and MPF Solution

Versatile system designed to address chronic plantar fasciitis and Morton's neuroma, two common soft-tissue foot indications



[www.acumed.net](http://www.acumed.net)

Acumed USA Campus  
5885 NE Cornelius Pass Road  
Hillsboro, OR 97124  
+1.888.627.9957

OsteoMed USA Campus  
3885 Arapaho Road  
Addison, TX 75001  
+1.800.456.7779

Acumed Iberica Campus  
C. Proción, 1  
Edificio Oficor  
28023 Madrid, Spain  
+34.913.51.63.57

**GEN00-21-E** | Effective: 2023/09 | © 2023 Acumed® LLC

These materials contain information about products that may or may not be available in any particular country or may be available under different trademarks in different countries. The products may be approved or cleared by governmental regulatory organizations for sale or use with different indications or restrictions in different countries. Products may not be approved for use in all countries. Nothing contained in these materials should be construed as a promotion or solicitation for any product or for the use of any product in a particular way that is not authorized under the laws and regulations of the country where the reader is located. Nothing in these materials should be construed as a representation or warranty as to the efficacy or quality of any product, nor the appropriateness of any product to treat any specific condition. Physicians may direct questions about the availability and use of the products described in these materials to their authorized Acumed distributor. Specific questions patients may have about the use of the products described in these materials or the appropriateness for their own conditions should be directed to their own physician.

OsteoMed® LLC is a wholly owned subsidiary of Acumed LLC.  
OsteoMed, ExtremiLock®, ExtremiFix™, EnCompass™, ExtremiFuse™, ExtremiFix™, FreedomPin®, FPS™, Hemi™, InterPhlex™, InstaFix™, KobyGard™, OTPS™, PrimaGraft®, ReFlexion™, and Talar-Fit™, are registered trademarks of OsteoMed LLC.

ExsoMed™ Corporation is a wholly owned subsidiary of Acumed LLC.  
ExsoMed, ArcPhix™, InFrame™, and INnate™ are trademarks of ExsoMed Corporation.

Acu-Loc®, Acumed®, Acute Innovations®, Acutrak®, Acutrak 2®, AcuTwist®, AcuTie®, Acu-Sinch®, BioBridge®, Biotrak®, Frag-Loc®, Hub Cap®, MINI-Calc®, Polarus®, RibLoc®, Tap-Loc®, Tip-Loc®, and TripleTwist™ are registered trademarks of Acumed LLC.